

Data in Azure

Memilavi
www.memilavi.com

<https://t.me/learningnets>



Data in Azure

- Azure provides many data solutions as cloud services
- Relational databases, NoSQL databases, object stores
- Fully managed services
- Can be part of Azure app or completely independent
- Various pricing models
- Always better than unmanaged solutions

Major Database Features

- What to look for when selecting a database?

Security

Network isolation, Encryption

Backup

Backup types, Retention Period

Availability

SLA, Replication, DR

Database on VM

- Azure VM can be setup with database software
- There are ready-made VMs in the marketplace

[Home](#) >

Oracle Database 12.2.0.1 Enterprise Edition

Oracle



Oracle Database 12.2.0.1 Enterprise Edition [Save for later](#)

Oracle

[Create](#) [Start with a pre-set configuration](#)

Deploy with Resource Manager ([change to Classic](#))

[Overview](#) [Plans](#) [Usage Information + Support](#)

Oracle Database 12c Enterprise Edition (12.2.0.1) is a next-generation database designed for the cloud. It offers more than 500 new features including a new multitenant architecture that simplifies consolidating databases onto the cloud and enables customers to manage many databases as one without changing their applications. Customers can choose a wide range of Oracle Database Enterprise Edition options to deliver on business users' performance, security, big data, cloud, and availability service-level expectations.

<https://t.me/learningnets>

Database on VM

- Pros of Database on VM:
 - Full flexibility
 - Full control

Database on VM

- Cons of Database on VM:
 - You have to take care of everything:
 - SLA
 - Updates
 - Availability
 - Security
 - Backups
 - And more...

Database on VM

- In this section we'll discuss only managed databases

Azure SQL

- Managed SQL Server on Azure
- Works like any other SQL Server using the same tools
- Great compatibility with on-prem SQL Server
 - Depends on the exact Azure SQL Flavor
- Offers built-in security, backups, availability and more
- Flexible pricing models

Azure SQL Flavors

Azure SQL Database

Elastic Pool

Managed Instance

Azure SQL Database

- Managed SQL Server on Azure
- Single database on a single server
- Automatic backups, updates, scaling
- Good compatibility with on-prem SQL Server
 - Not all features are supported

Azure SQL Database

- Security:
 - IP firewall rules
 - Service Endpoints
 - SQL & Azure AD Authentication
 - Secure communication (TLS)
 - Data encrypted by default (TDE)

Azure SQL Database

- Backup:

Full



Every week

Differential



Every 12-24 hrs

Transaction Log



Every 5-10 mins

Azure SQL Database

- Retention Period:
 - Regular backup: 7-35 days (default is 7)
 - Long term backup: up to 10 years

Azure SQL Database

- Availability:
 - Backup is stored in a geo-redundant storage
 - Active geo-replication
 - SLA: 99.9% - 99.995%, depends on tier and redundancy

Azure SQL Database

- Compute Tiers:

Provisioned

- Pay for allocated resources regardless of actual use
- Can be reserved

Serverless

- Pay for actual use – vCore + RAM / second
- Automatically paused when inactive (pay just for storage)
- Slight delay when warming up
- Can't be reserved

Elastic Pool

- Based on Azure SQL
- Allows storing multiple databases on single server
- Great for databases with low average utilization and infrequent spikes

Elastic Pool

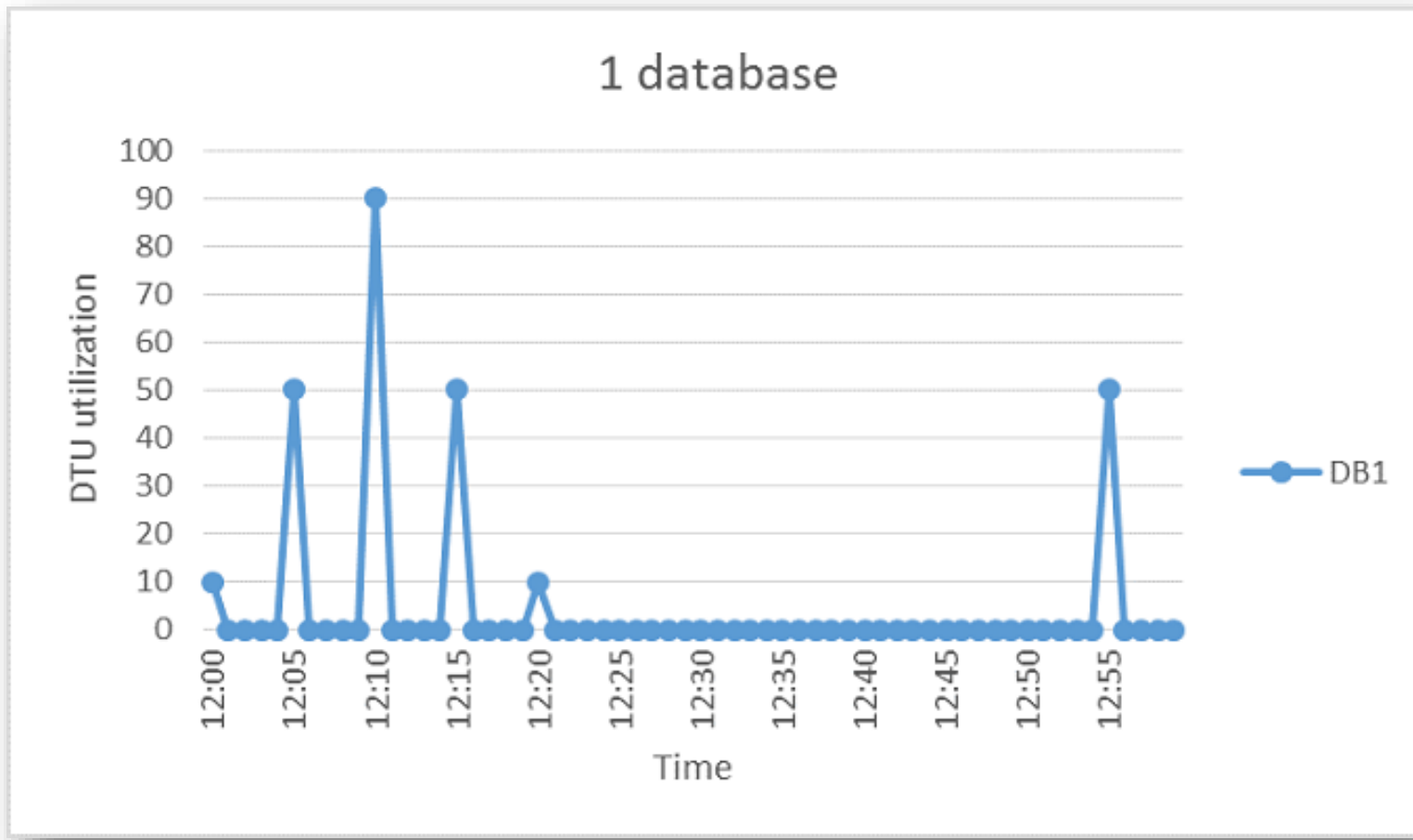

Elastic Pool

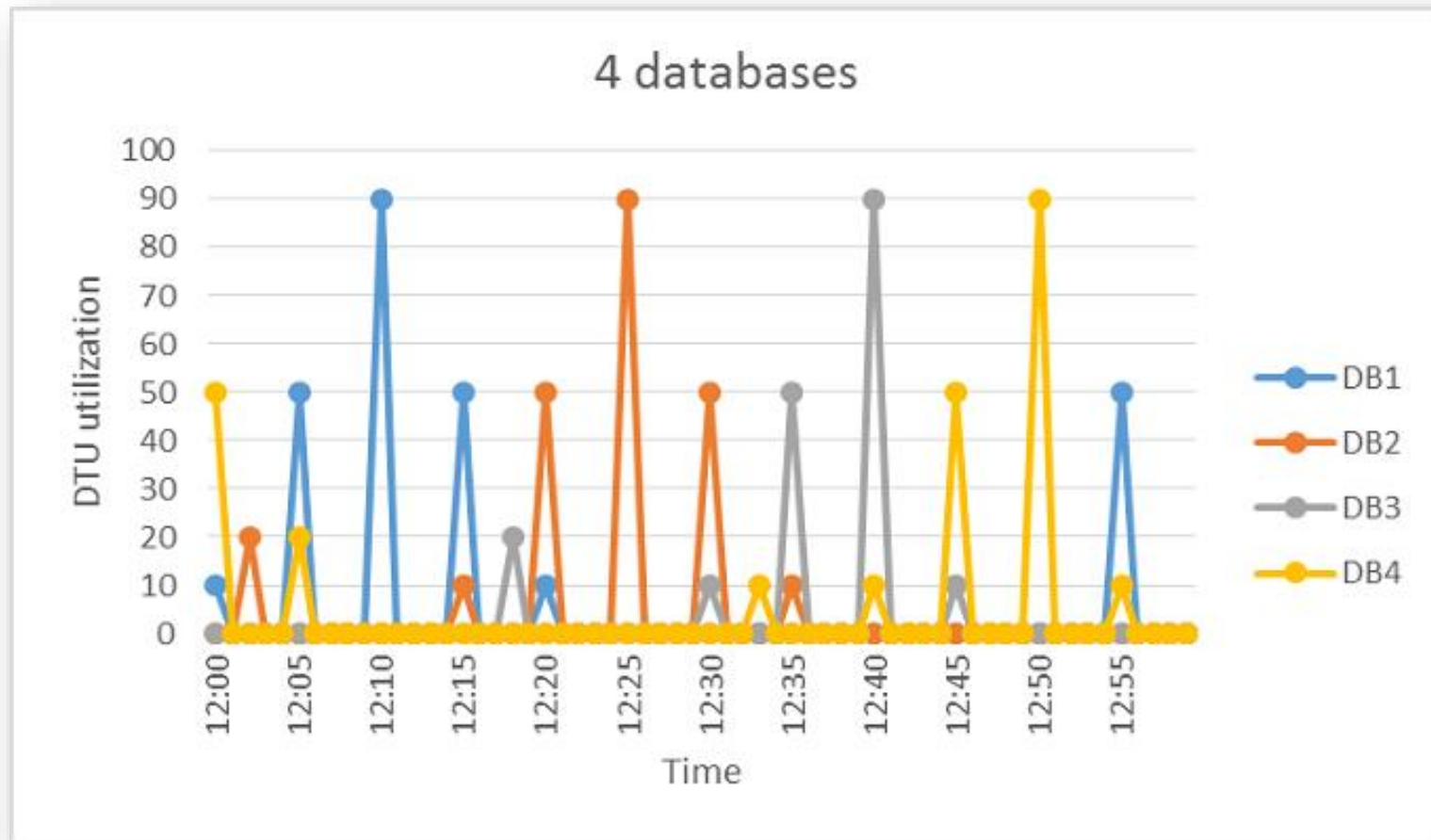

Elastic Pool

- Cost effective
- Purchase the compute resources you need, not the database

Managed Instance

- Closer to the on-prem SQL Server
- Near 100% compatible with on-prem SQL
- Can be deployed to VNet
- Business model close to on-prem one

Managed Instance

- Main differences:
 - No active geo-replication
 - SLA: 99.99%
 - Supports built-in functions
 - Runs CLR code
 - No auto scaling & tuning
 - No availability zone
 - No serverless tier
 - No Hyperscale

Azure SQL Pricing

A 3D rendering of a complex, circular maze made of white walls. The maze has multiple concentric rings and intricate internal paths. In the center of the maze, there is a green rectangular box with a thin border. Inside this box, the text "Quite complicated..." is written in a green, sans-serif font. The maze is set against a light blue and white background.

Quite complicated...

Flavor

Service Tier

Instance Type

Instance (vCores)

Managed Instance

General Purpose

Business Critical

Instance Pools

Single Instance

8...80

Azure SQL

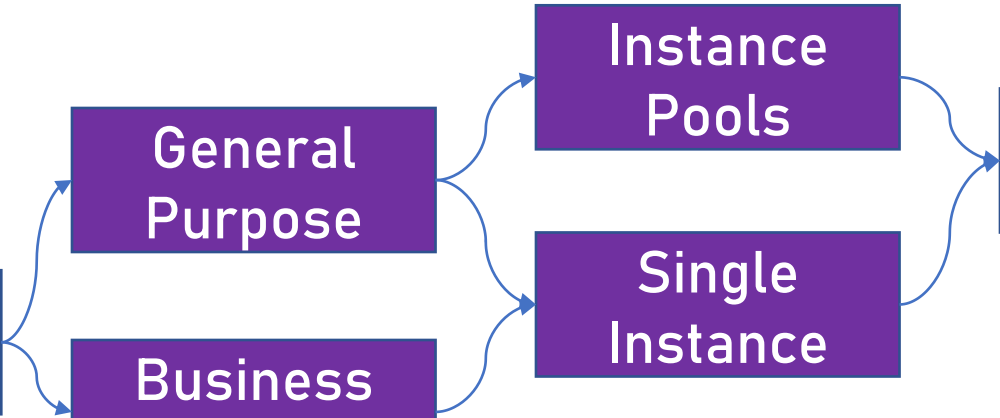

Azure SQL Managed Instance

REGION:	TIER:	BACKUP STORAGE TIER:	SERVICE TIER:
West India	Managed Instance	RA-GRS	General Purpose
INSTANCE TYPE:	GENERATION:	INSTANCE:	
Single Instance	Gen 5	8 vCore	

Savings Options

Save up to 73% on pay as you go prices with 1 year or 3 year reserved options.

Compute

- Pay as you go
- 1 year reserved
- 3 year reserved

\$977.84

Average per month
(\$0.00 charged upfront)

SQL License

- Pay as you go
- Azure Hybrid Benefit

\$583.80

Average per month
(\$0.00 charged upfront)

= \$1,561.65
Average per month
(\$0.00 charged upfront)

1	×	730	Hours	?
Instances				

Azure SQL Managed Instance

REGION:

West India

TIER:

Managed Instance

BACKUP STORAGE TIER:

RA-GRS

SERVICE TIER:

Business Critical

INSTANCE TYPE:

Single Instance

GENERATION:

Gen 5

INSTANCE:

24 vCore

Savings Options

Save up to 73% on pay as you go prices with 1 year or 3 year reserved options.

Compute

- Pay as you go
- 1 year reserved
- 3 year reserved

\$5,867.08

Average per month
(\$0.00 charged upfront)

SQL License

- Pay as you go
- Azure Hybrid Benefit

\$6,570.00

Average per month
(\$0.00 charged upfront)

= \$12,437.08

Average per month
(\$0.00 charged upfront)

Azure SQL Managed Instance

REGION:

West India

TIER:

Managed Instance

BACKUP STORAGE TIER:

RA-GRS

SERVICE TIER:

Business Critical

INSTANCE TYPE:

Single Instance

GENERATION:

Gen 5

INSTANCE:

24 vCore

Savings Options

Save up to 73% on pay as you go prices with 1 year or 3 year reserved options.

Compute

- Pay as you go
- 1 year reserved
- 3 year reserved

COMPUTE PAYMENT OPTIONS:

Upfront

\$2,639.91

Average per month
(\$95,036.89 charged upfront)

SQL License

- Pay as you go
- Azure Hybrid Benefit

\$6,570.00

Average per month
(\$0.00 charged upfront)

= **\$9,209.91**

Average per month
(\$95,036.89 charged upfront)

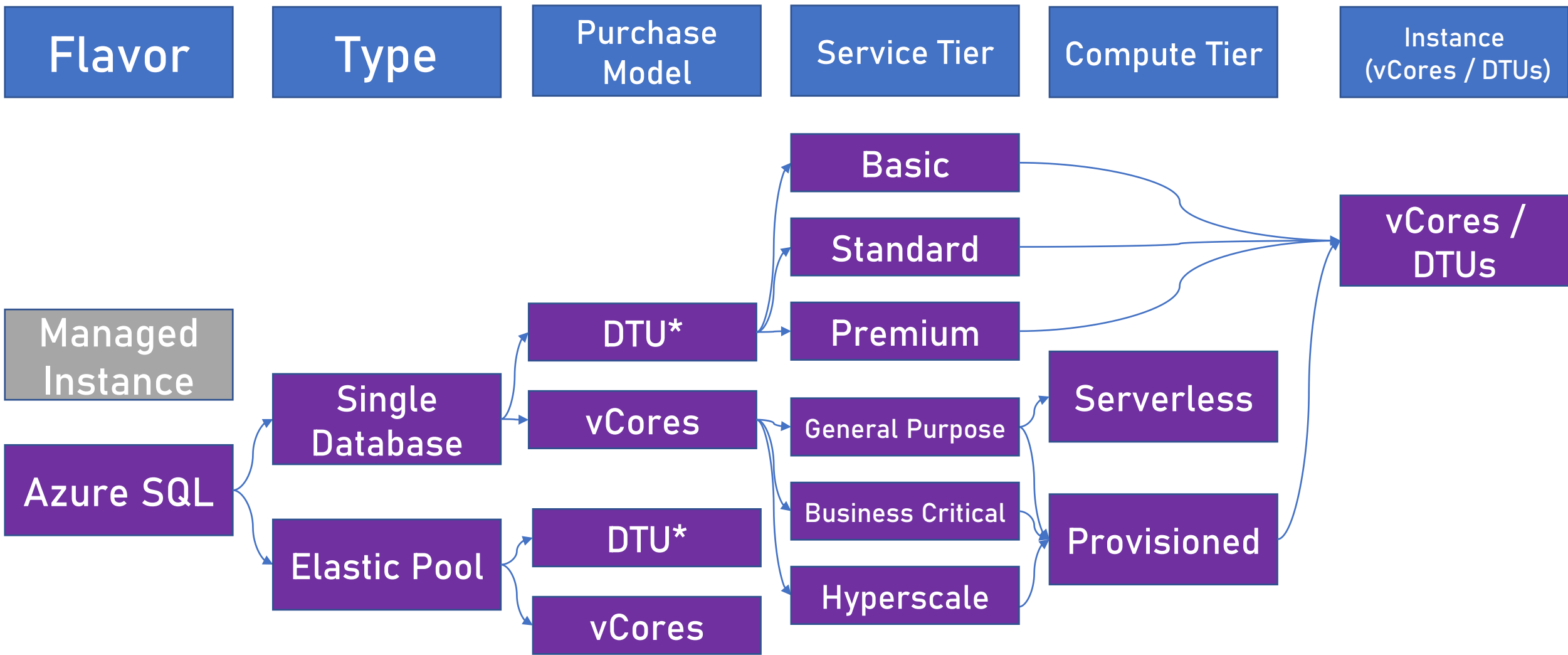

1 vCore =~ 100 DTU

<https://t.me/learningnets>

Flavor

Type

Purchase Model

Service Tier

Instance (vCores / DTUs)

Managed Instance

Azure SQL

Single Database

Elastic Pool

DTU*

vCores

DTU*

vCores

Basic

Standard

Premium

General Purpose

Business Critical

vCores / DTUs

1 vCore =~ 100 DTU

<https://t.me/learningnets>

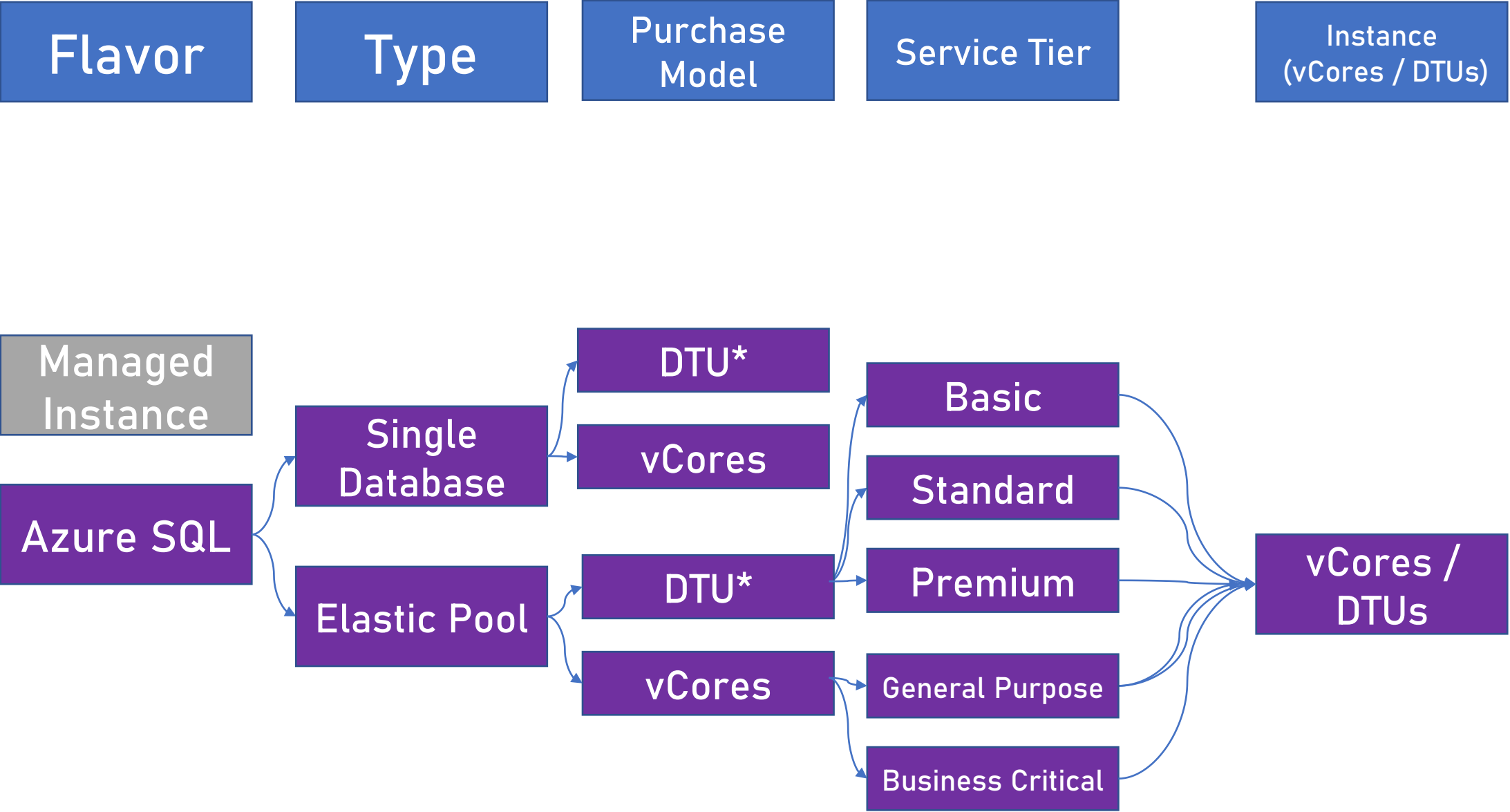

Azure SQL Database

REGION:

East US

TYPE:

Single Database

BACKUP STORAGE TIER:

RA-GRS

PURCHASE MODEL:

DTU

SERVICE TIER:

Standard

PERFORMANCE LEVEL:

S1: 20 DTUs, 250 GB included storage per DB, \$0.0403/hour

1

×

730

Hours

Databases

= \$29.43

Azure SQL Database

REGION:

East US

TYPE:

Single Database

BACKUP STORAGE TIER:

RA-GRS

PURCHASE MODEL:

vCore

SERVICE TIER:

Business Critical

HARDWARE TYPE:

Gen 5

INSTANCE:

12 vCore

Compute

1

Instances

x

730

Hours

i

Savings Options

Save up to 73% on pay as you go prices with 1 year or 3 year reserved options.

Compute

- Pay as you go
- 1 year reserved
- 3 year reserved

\$2,666.85

Average per month
(\$0.00 charged upfront)

SQL License

- Pay as you go
- Azure Hybrid Benefit

\$3,285.00

Average per month
(\$0.00 charged upfront)

= \$5,951.85

Average per month
(\$0.00 charged upfront)

Azure SQL Database

REGION:

East US

TYPE:

Single Database

BACKUP STORAGE TIER:

RA-GRS

PURCHASE MODEL:

vCore

SERVICE TIER:

General Purpose

COMPUTE TIER:

Serverless

HARDWARE TYPE:

Gen 5

Billed vCores

Maximum vCores:

8

Minimum vCores:

2

4

CPU Used (vCores)

12

Memory used (GB)

2678400

Duration (in seconds, max 2,678,400 seconds (744 hours))

Minimum memory

6 GB

Maximum memory

24 GB

Billed vCores ⓘ

4

Highly inaccurate

= \$1,552.75

Which Azure SQL to Choose?

Are you migrating
an on-prem SQL?

→ Managed Instance

Do you need multiple,
mostly low-utilization DBs?

→ Elastic Pool

All other cases

→ Azure SQL

Cosmos DB

- Fully managed NoSQL database
 - Amazing performance - <10ms for 99% of operations
 - Globally distributed
 - Fully automatic management – updates, scaling, fixes etc.
 - Multiple APIS:
 - SQL, Mongo, Gremlin, Azure Table, Cassandra (per account)
- <https://t.me/learningnets>

Cosmos DB

- Hierarchical:

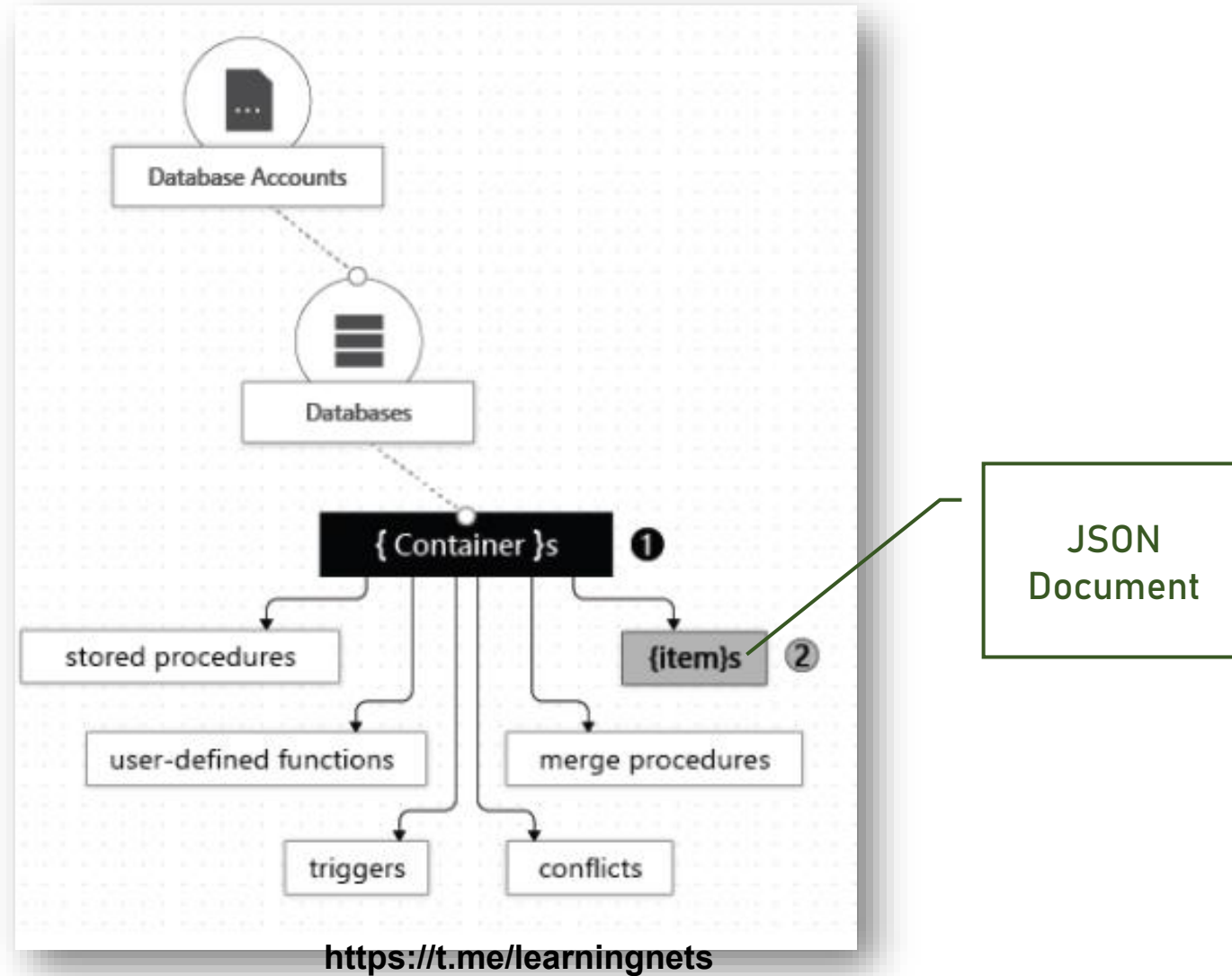

Cosmos DB Availability

- Can be distributed across many regions (configurable)
- API automatically picks the closest one
- When using write replication SLA is 99.999% (!)
- Managed automatically, no code changes required

Cosmos DB Backup

- Full backup every 1-24 hours (default is 4)
- Retention period 20-30 days (default is 30)

Cosmos DB Security

- IP firewall rules
- Service Endpoints
- Private Endpoints
- Azure AD Authentication
- Secure communication (TLS)
- Data encrypted by default

Cosmos DB Partitions

- Data items are divided to partitions
- Logical group of items based on a specific property
- Example: In a cars database, the Model can be a partition property

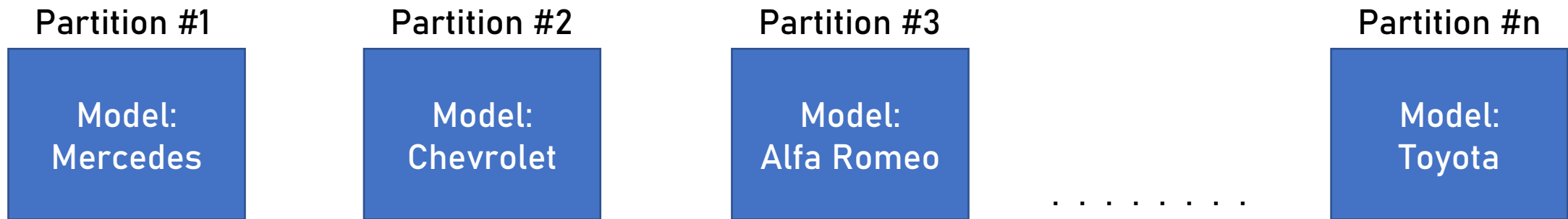

Cosmos DB Partitions

- Partitions are the basic scale unit in Cosmos DB
- Distribution and scale are per partitions
- Make sure items are divided as evenly as possible
- It's extremely important to select the right partition property
- Cannot be modified

Recording of L7S5 from the Architecture course

Cosmos DB Consistency Levels

- Traditionally:
 - Relational DB – Strong consistency. Call returns only after successful commit in all replicas (High availability)
 - NoSQL DB – Eventual consistency. Call returns immediately, commit in replicas happens later (Low latency)

High Availability \neq Low Latency

Cosmos DB Consistency Levels

- Cosmos DB offer five consistency levels:
 - Strong (\leq As in regular relational DB)
 - Bounded Staleness
 - Session
 - Consistent Prefix
 - Eventual (\leq As in regular NoSQL DB)

Cosmos DB Consistency Levels

- The basic question with consistency is:
 - If region X updates an item, and region Y reads this item, which version will it get?

Strong

- Region Y will get the last version of the item updated in region X
- Used for mission critical data

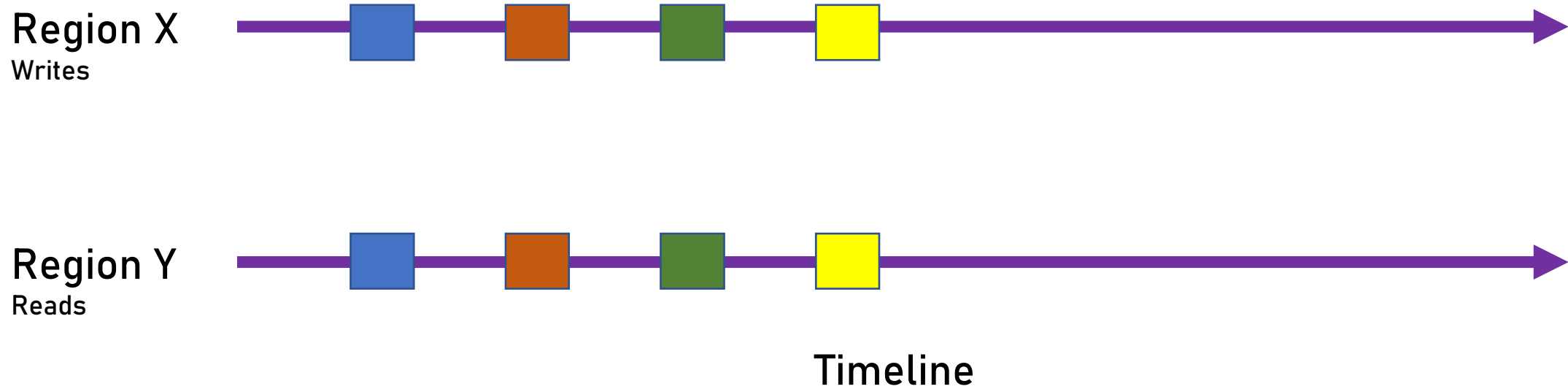

Bounded Staleness

- Region Y will lag behind region X by K versions or T time
- Keeps the order of the versions
- Used for low write latency and when order is important

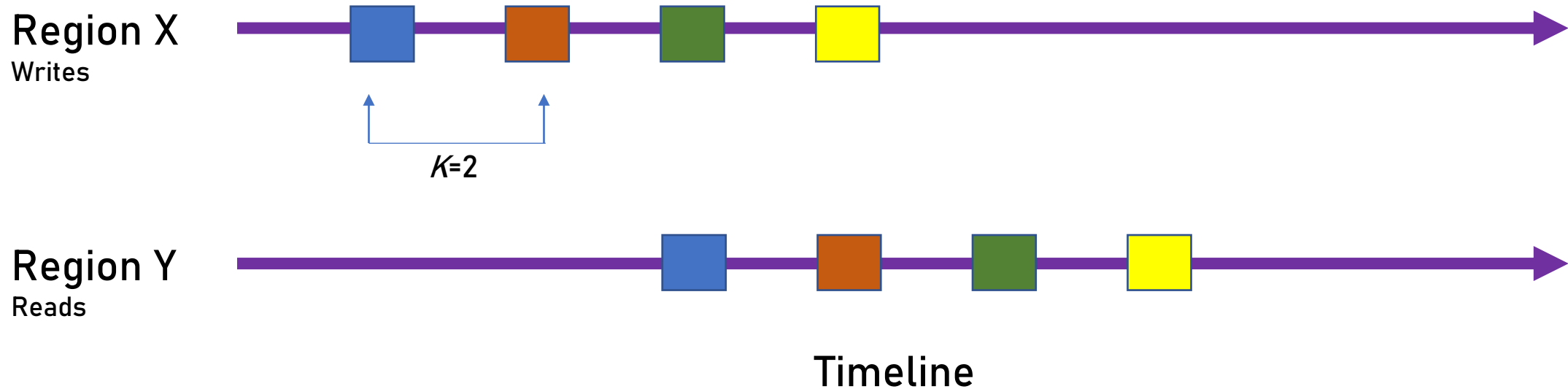

Session

- In a client session – Strong consistency
- Other clients – Consistent Prefix (sometimes Eventual)

Consistent Prefix

- Keeps the order of the versions
- No guarantee of the lag size (as opposed to Bounded Context)
- Used for low write latency and when reads are infrequent

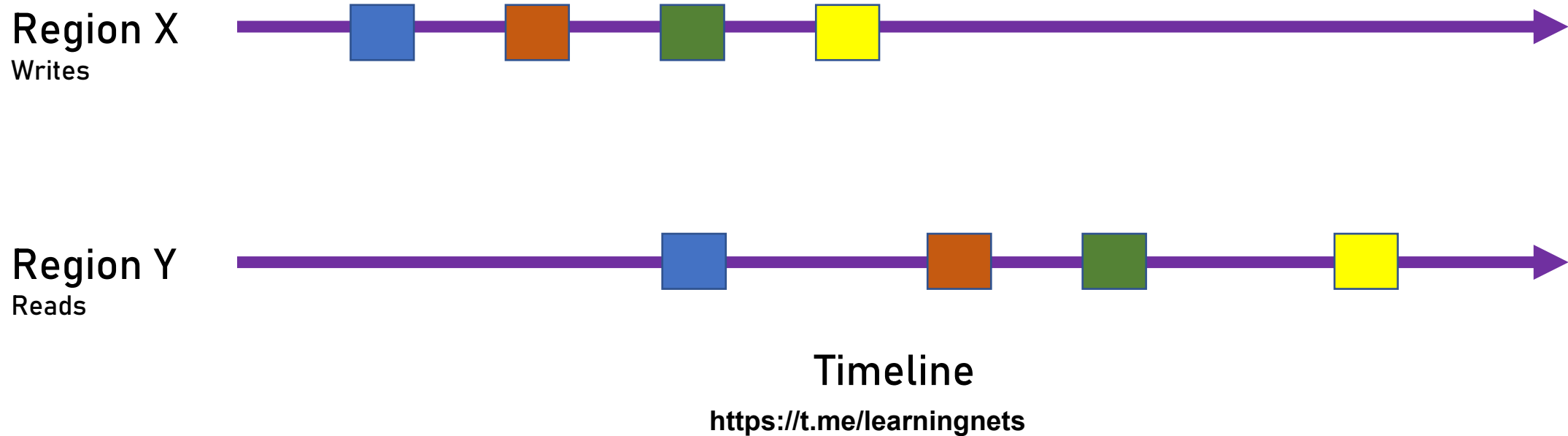

Eventual

- No order guarantee
- No guarantee of the lag size (as opposed to Bounded Context)
- Used for count of Retweets, Likes, etc.

Region X
Writes



Region Y
Reads



Timeline

<https://t.me/learningnets>

Cosmos DB Consistency Levels

- Configured at the account level
- Can be relaxed on the request level

Cosmos Pricing

- Based on RU/s
 - Request Unit per Second
- 1 RU = Read item of size 1KB
 - Read = Get the item by its ID, not by query

Cosmos Pricing

- 1 RU/s = Read 1 item of 1KB in 1 sec
- 400 RU/s = Read 400 items of 1KB in 1 sec
- Update, delete, insert, query – more than 1 RU
- You can see the actual RU consumed in the response header of the results

Cosmos Pricing

- Pricing based on:
 - Operations type: Provisioned, Auto Scale, Serverless
 - Write Regions
 - No. of provisioned RU/s

Cosmos Pricing

- Database Operations:
 - Provisioned – Predefined number of RU/s, can be changed manually later. Offers reserved capacity up to 65% discount
 - Auto Scale – Set the maximum RU/s, Cosmos scales up to this number. Good for unpredictable loads
 - Serverless – Pay for what you use. In Preview, no SLA

Azure Cosmos DB

DATABASE OPERATIONS:

Standard provisioned throughput (manual) ▼

WRITE REGIONS:

Single Region Write (Single-Master) ▼

Savings Options

Save up to 65% on pay as you go prices with 1-year or 3-year reserved capacity for Azure Cosmos DB.

- Pay as you go
- 1 year reserved capacity
- 3 year reserved capacity

\$23.36
Average per month
(\$0.00 charged upfront)

Request units per second (RU/s)

4
x100 RU/s

×

730 Hours ▼



ENABLE AVAILABILITY ZONES

Region:
East US ▼

4
x100 RU/s

×

730
Hours

×

\$0.008
Per hour

=

\$23.36

Azure Cosmos DB

DATABASE OPERATIONS:

Standard provisioned throughput (manual) ▾

WRITE REGIONS:

Multiple Region Write (Multi-Master) ▾

Savings Options

Save up to 65% on pay as you go prices with 1-year or 3-year reserved capacity for Azure Cosmos DB.

Pay as you go

1 year reserved capacity

3 year reserved capacity

\$584.00

Average per month

(\$0.00 charged upfront)

Request units per second (RU/s)

50

X100 RU/S

×

730

Hours ▾

Region:

East US ▾

50
x100 RU/s

×

730
Hours

×

\$0.016
Per hour

=

\$584.00

Azure Cosmos DB

DATABASE OPERATIONS:

Autoscale provisioned throughput

WRITE REGIONS:

Single Region Write (Single-Master)

Savings Options

Pay as you go

\$876.00

Average per month

(\$0.00 charged upfront)

Maximum Request Units Per Second (RU/s)

10

x1,000 RU/s

×

730

Hours

▼

×

100

AVERAGE %
UTILIZATION

ⓘ

ENABLE AVAILABILITY ZONES

Region:

East US

▼

10

x1,000 RU/s

×

730

Hours

×

\$0.120

Per hour

×

100%

Average Utilization

=

\$876.00

Azure MySQL

- Managed MySQL on Azure
- Works like any other MySQL database using the same tools
- Great compatibility with on-prem MySQL database
- Offers built-in security, backups, availability and more

Azure MySQL

- Security:
 - IP firewall rules
 - Service Endpoints
 - Private Endpoints
 - Regular & Azure AD Authentication
 - Secure communication (TLS)
 - Data encrypted by default

Azure MySQL

- Backup:
 - Depends on Service Tier:
 - Basic – Full backup: daily
 - General Purpose up to 4GB:
 - Full backup: once a week
 - Differential backup: twice a day
 - Transaction log backup: every 5 minutes

Azure MySQL

- Backup:
 - Depends on Service Tier:
 - General Purpose up to 16GB:
 - Full backup: Once created
 - Differential backup: once a day
 - Transaction log backup: every 5 minutes

Azure MySQL

- Retention Period:
 - 7-35 days (default is 7)
 - No native long term retention support

Azure MySQL

- Availability:
 - Backup is stored in a geo-redundant storage
 - In General Purpose and Memory Optimized tiers
- SLA: 99.99%

Azure MySQL Pricing

- Pricing based on:
 - Tier:
 - Basic – Require light compute and I/O performance (ie. dev)
 - General Purpose – Most business workloads
 - Memory Optimized – Require in-memory performance
 - Compute (no. of vCores)

Azure MySQL Pricing

- Flexible Server deployment – currently in preview, not recommended
- Reservations exist

Azure Database for MySQL

REGION:
West Europe

DEPLOYMENT OPTION:
Single Server

TIER:
Basic

COMPUTE:
Gen 5, 1 vCore, \$0.0398/hour

Savings Options

Save up to 51% on pay as you go prices with the 1 year reserved option.

1 year reserved option is not available for your instance selection.

3 year reserved option is not available for your instance selection.

- Pay as you go
- 1 year reserved
- 3 year reserved

\$29.05
Average per month
(\$0.00 charged upfront)

1 Servers × 730 Hours

= \$29.05
Average per month

Azure Database for MySQL

REGION:

West Europe



DEPLOYMENT OPTION:

Single Server



TIER:

General Purpose



COMPUTE:

Gen 5, 4 vCore, \$0.4168/hour



Savings Options

Save up to 51% on pay as you go prices with the 1 year reserved option.

- Pay as you go
- 1 year reserved (~35% savings)
- 3 year reserved (~53% savings)

\$304.26

Average per month
(\$0.00 charged upfront)

1

Servers

×

730

Hours



=

\$304.26

Average per month
(\$0.00 charged upfront)

Azure PostgreSQL

- Managed PostgreSQL on Azure
- Works like any other PostgreSQL database using the same tools
- Great compatibility with on-prem PostgreSQL database
- Includes Hyperscale deployment
- Offers built-in security, backups, availability and more

Azure PostgreSQL

- Security:
 - IP firewall rules
 - Service Endpoints
 - Private Endpoints
 - Regular & Azure AD Authentication
 - Secure communication (TLS)
 - Data encrypted by default

Azure PostgreSQL

- Backup:
 - Depends on storage size:
 - up to 4GB:
 - Full backup: once a week
 - Differential backup: twice a day
 - Transaction log backup: every 5 minutes

Azure PostgreSQL

- Backup:
 - Depends on storage size:
 - up to 16GB:
 - Full backup: Once created
 - Differential backup: thrice a day
 - Transaction log backup: every 5 minutes

Azure PostgreSQL

- Retention Period:
 - 7-35 days (default is 7)
 - No native long term retention support

Azure PostgreSQL

- Availability:
 - Backup is stored in a geo-redundant storage
 - In General Purpose and Memory Optimized tiers
- SLA: 99.99%

Azure Storage

- Object store
- Massively scalable
- Accessible via HTTP or HTTPS
- Client libraries for almost every language
- Durable and highly available

Azure Storage Types

Blobs	→ Object Store	This one we like 😊
Files	→ File shares for cloud and on-prem deployments	Related more to compute, quite low level
Queues	→ Queues (duh...)	We'll discuss this in the Messaging section
Tables	→ NoSQL data store	Similar to CosmosDB, but less optimized for performance and availability (cheaper, though...)
Disks	→ Storage volumes for Azure VMs	Managed by the VM, nothing to deal with here

Azure Blobs Storage

- Object store (Blob = Binary Large Object)
- Great for files, videos, documents, large texts etc.
- Up to 4.77TB per file (!), 190TB in preview (!!)
- Extremely cost effective
- Massively scalable
- Great availability options
- Extremely easy to use
- Usually used in conjunction with SQL / NoSQL database

Azure Blobs Storage

- Security:
 - IP firewall rules
 - Service Endpoints
 - Private Endpoints
 - Shared Access Signatures
 - Access Keys & Azure AD Authentication
 - Secure communication (TLS)
 - Data encrypted by default

Azure Blobs Storage

- Structure:

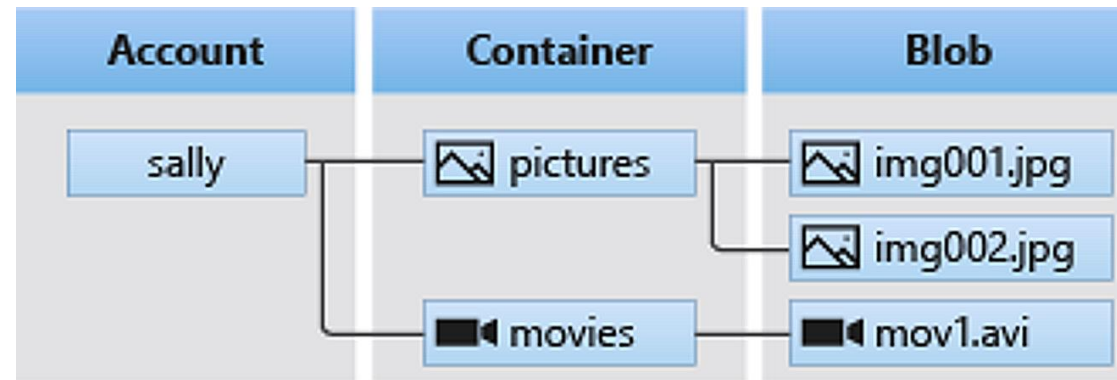

Azure Blobs Storage Redundancy

- 6 options:

LRS

Locally Redundant Storage
Data is synchronously copied 3 times within the same zone

ZRS

Zone Redundant Storage
Data is synchronously copied to 3 zones in the Region

GRS

Geo Redundant Storage
Data is synchronously copied 3 times within the same zone, and then copied asynchronously to paired Region. Data in the secondary Region is accessible only after Failover process

GZRS

Geo-Zone Redundant Storage
Data is synchronously copied to 3 zones in the Region, and then copied asynchronously to paired Region. Data in the secondary Region is accessible only after Failover process

RA-GRS

Read Access-Geo Redundant Storage
Data is synchronously copied 3 times within the same zone, and then copied asynchronously to paired Region. There's a read-access to the data in the secondary Region

<https://t.me/learningnets>

RA-GZRS

Read Access-Geo-Zone Redundant Storage
Data is synchronously copied to 3 zones within the same Region, and then copied asynchronously to paired Region. There's a read-access to the data in the secondary Region

Azure Blobs Storage Failover

- Normal circumstances:

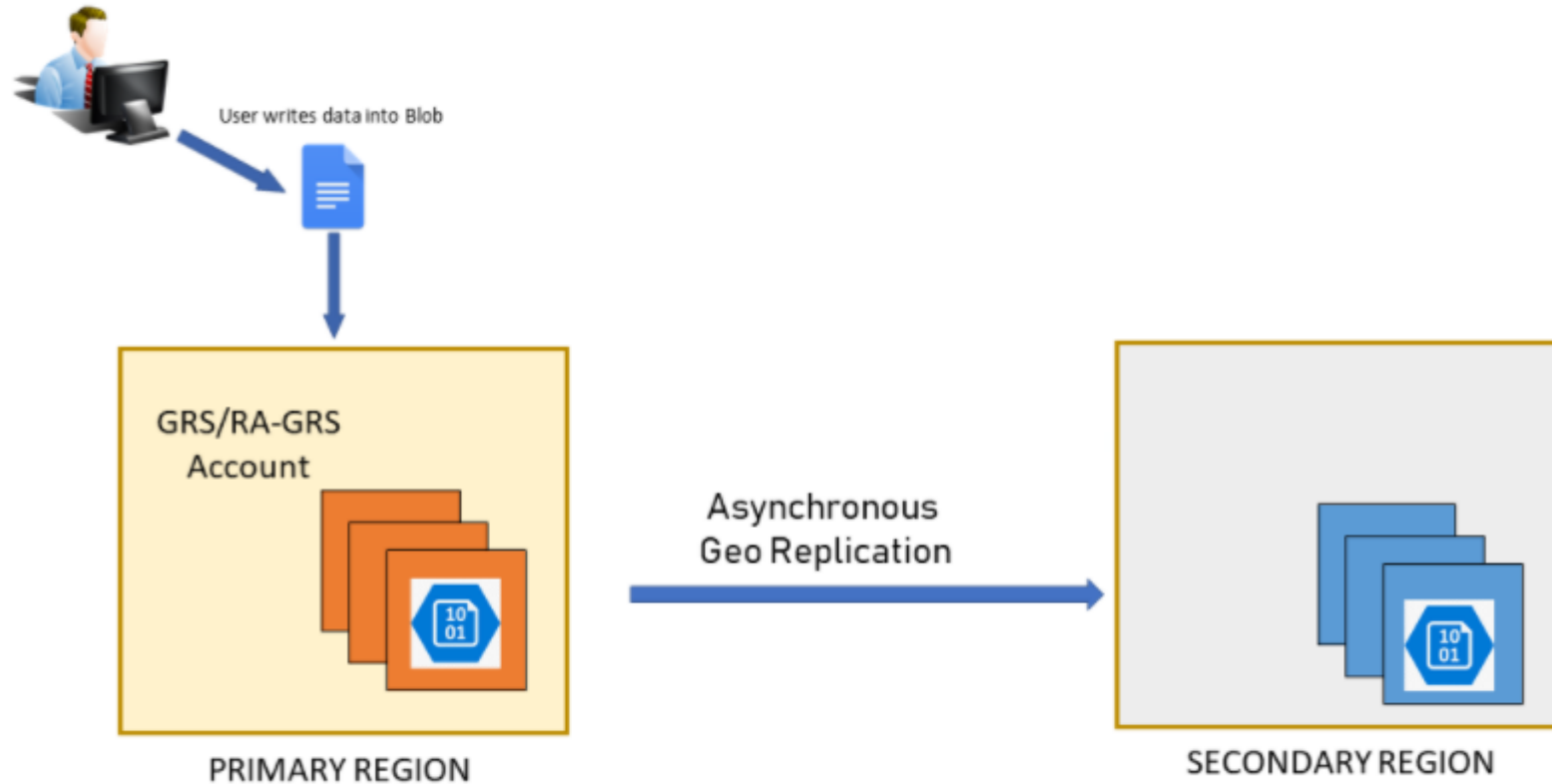

Azure Blobs Storage Failover

- Primary Region fails:

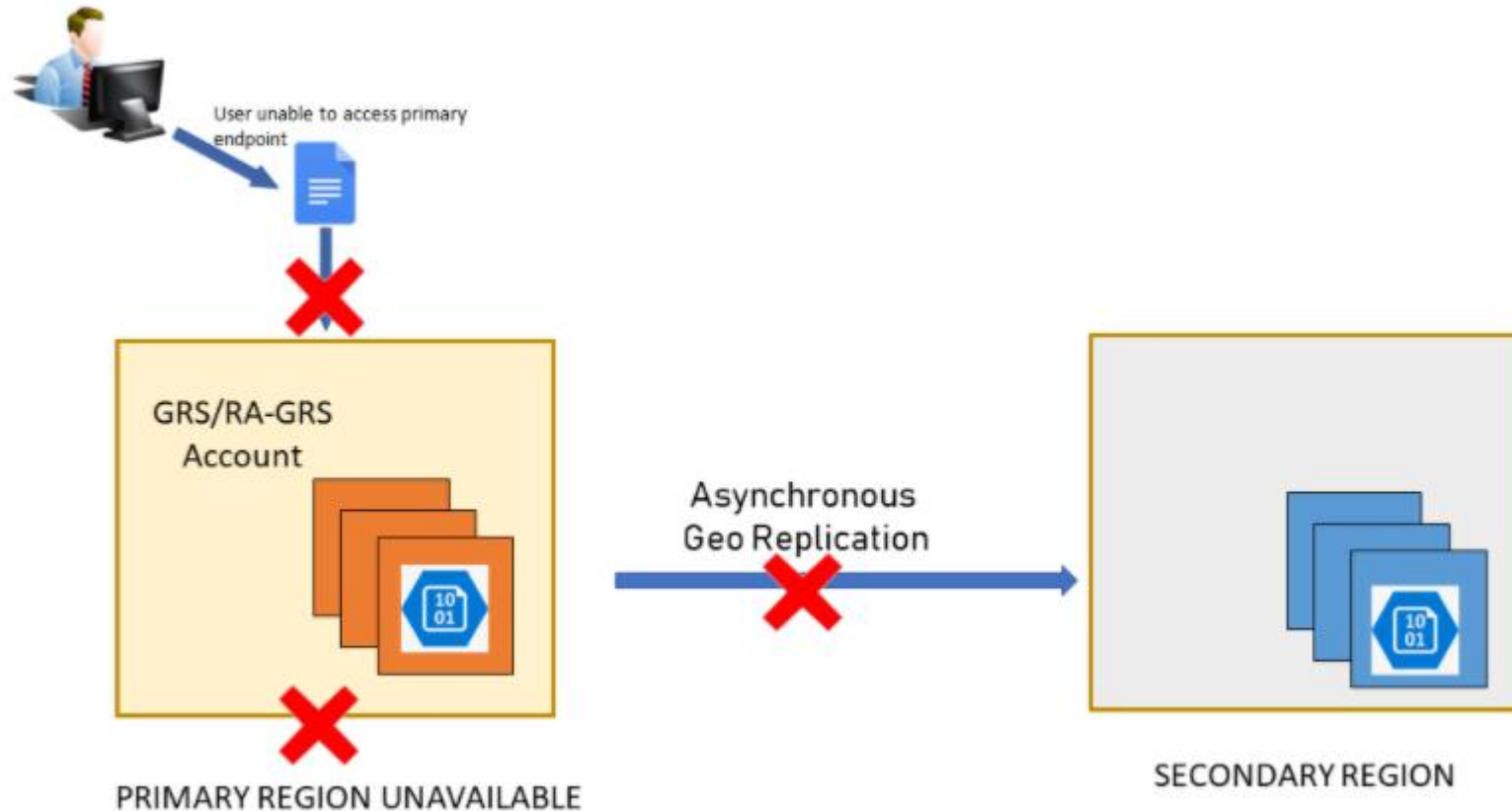

Azure Blobs Storage Failover

- Failover to the secondary Region:

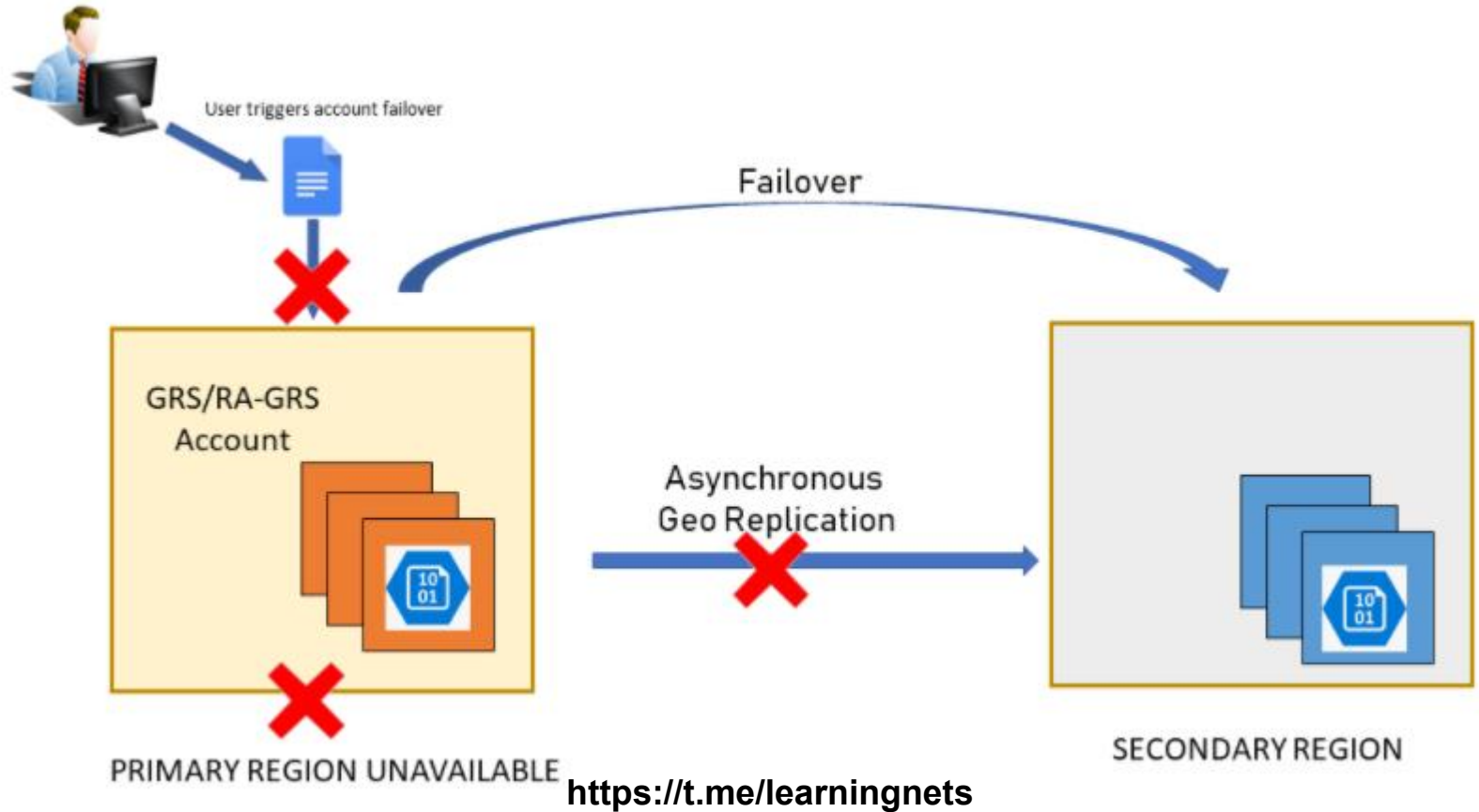

Azure Blobs Storage Failover

- Can be initiated via the:
 - Portal
 - Azure CLI
 - PowerShell

Azure Blobs Storage Tiers

- Blobs are uploaded to one of three tiers:

Hot

- Data that's accessed frequently
- Best SLA (99.9%)
- Highest storage costs
- Lowest access costs
- Examples:
 - Photos to display
 - Documents to show

Cool

- Data that's accessed infrequently
- Slightly lower SLA (99%)
- Lower storage costs
- Higher access costs
- Must be stored for at least 30 days (or early deletion fees applied)
- Examples:
 - Short term backup
 - Data for future processing

Archive

- Data for archival
- Stored offline, no SLA
- Can take hours to retrieve
- Lowest storage costs
- Highest access costs
- Must be stored for at least 180 days (or early deletion fees applied)

Azure Blobs Storage Tiers

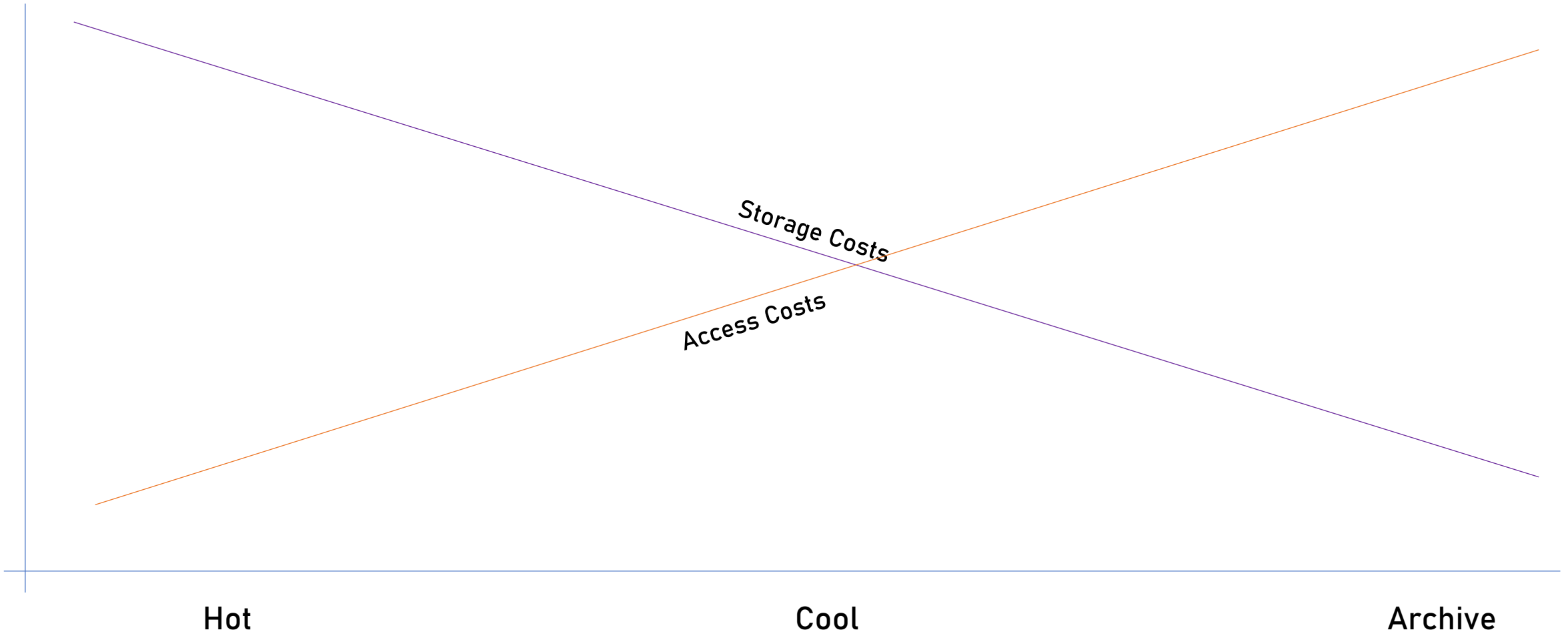

Azure Blobs Storage Tiers

- Retrieval time is the same in Hot and Cool tiers
- Archive tier does not support ZRS, GRS and RA-GRS redundancy
- Using RA-G(Z)RS, SLA improves to 99.99% (Hot) and 99.9% (Cool)
- Tier is set at account level, can be modified per blob
- Moving between tiers can be automated by lifecycle rules

Azure Blobs Storage Pricing

- Based on:
 - Redundancy option
 - Access tier
 - Capacity

Storage Accounts

REGION:

West Europe

TYPE:

Block Blob Storage

PERFORMANCE TIER:

Standard

STORAGE ACCOUNT TYPE:

General Purpose V2

REDUNDANCY:

LRS

ACCESS TIER:

Hot

Capacity

1000

GB

Savings Options

Save up to 38% on pay-as-you-go prices with 1-year or 3-year Azure Storage Reserved Capacity. [Learn more about Azure Storage Reserved Capacity pricing.](#)

Pay as you go

1 year reserved

3 year reserved

\$19.60

Average per month
(\$0.00 charged upfront)

= \$19.60

Average per month
(\$0.00 charged upfront)

Write Operations

100000

Operations

×

\$0.054

Per 10,000 operations

= \$0.54



The following API calls are considered Write Operations: PutBlob, PutBlock, PutBlockList, AppendBlock, SnapshotBlob, CopyBlob and SetBlobTier (when it moves a Blob from Hot to Cool, Cool to Archive or Hot to Archive).

List and Create Container Operations

100000

Operations

×

\$0.054

Per 10,000 operations

= \$0.54

<https://t.me/learningnets>

Storage Accounts

REGION:

West Europe

TYPE:

Block Blob Storage

PERFORMANCE TIER:

Standard

STORAGE ACCOUNT TYPE:

General Purpose V2

REDUNDANCY:

LRS

ACCESS TIER:

Cool

Capacity

1000

GB



Early deletion fees may apply and are not included. [Learn more about early deletion fees.](#)

Savings Options

Save up to 38% on pay-as-you-go prices with 1-year or 3-year Azure Storage Reserved Capacity. [Learn more about Azure Storage Reserved Capacity pricing.](#)

Pay as you go

1 year reserved

3 year reserved

\$10.00

Average per month
(\$0.00 charged upfront)

= \$10.00

Average per month
(\$0.00 charged upfront)

Write Operations

100000

Operations

×

\$0.100

Per 10,000 operations

= \$1.00



The following API calls are considered Write Operations: PutBlob, PutBlock, PutBlockList, AppendBlock, SnapshotBlob, CopyBlob and SetBlobTier (when it moves a Blob from Hot to Cool, Cool to Archive or Hot to Archive).

List and Create Container Operations

100000

Operations

×

\$0.054

Per 10,000 operations

= \$0.54

<https://t.me/learningnets>

Storage Accounts

REGION:

West Europe

TYPE:

Block Blob Storage

PERFORMANCE TIER:

Standard

STORAGE ACCOUNT TYPE:

General Purpose V2

REDUNDANCY:

RA-GRS

ACCESS TIER:

Cool

Capacity

1000

GB



Early deletion fees may apply and are not included. [Learn more about early deletion fees.](#)

Savings Options

Save up to 38% on pay-as-you-go prices with 1-year or 3-year Azure Storage Reserved Capacity. [Learn more about Azure Storage Reserved Capacity pricing.](#)

Pay as you go

1 year reserved

3 year reserved

\$25.00

Average per month

(\$0.00 charged upfront)

= \$25.00

Average per month
(\$0.00 charged upfront)

Write Operations

100000

Operations

×

\$0.200

Per 10,000 operations

= \$2.00



The following API calls are considered Write Operations: PutBlob, PutBlock, PutBlockList, AppendBlock, SnapshotBlob, CopyBlob and SetBlobTier (when it moves a Blob from Hot to Cool, Cool to Archive or Hot to Archive).

List and Create Container Operations

100000

Operations

×

\$0.108

Per 10,000 operations

= \$1.08

<https://t.me/learningnets>

Azure Redis

- Managed Redis on Azure
- Provides lightning-fast in-memory, distributed cache
- Great for short-lived, frequently accessed data
 - ie. shopping cart, stock quotes
- Fully compatible with OSS Redis (community edition) and Enterprise Redis – depends on service tiers

Azure Redis

- Security:
 - IP firewall rules
 - Service Endpoints
 - Private Endpoints
 - Secure communication (TLS)

Azure Redis Service Tiers

Basic	→ Based on a single VM, no SLA, no distribution. Good for dev/test
Standard	→ Based on two VMs, replicated. SLA – Up to 99.9%
Premium	→ High-performance, better throughput, lower latency. SLA – Up to 99.95%
Enterprise	→ Based on Redis Enterprise, offers additional features (Redisearch, RedisBloom and more). SLA – Up to 99.99%
Enterprise Flash	→ Uses non-volatile memory. Reduces storage cost. SLA – Up to 99.99%

Azure Redis Pricing

- Based on:
 - Tier
 - Memory

Azure Cache for Redis

REGION:

West US

TIER:

Basic

INSTANCE:

C0: 250 MB cache, \$0.022/hour

1

Instances

×

730

Hours

Upfront cost

\$0.00

Monthly cost

\$16.06

Azure Cache for Redis

REGION:

West US

TIER:

Premium

INSTANCE:

P3: 26624 MB cache, \$2.218/hour

Savings Options

- Pay as you go
- 1 year reserved (~36% savings)
- 3 year reserved (~55% savings)

\$1,619.14

Average per month
(\$0.00 charged upfront)

= \$1,619.14

Average per month
(\$0.00 charged upfront)

1

x

730

Hours

Instances

Upfront cost

\$0.00

Monthly cost

\$1,619.14

Are we done?

- Nope 😊
 - The Orders Function is publicly available and synchronous
 - The inventory page is open for everyone
 - We don't really know how the app is functioning
 - The website is not redundant – what happens if the whole region goes down?

Selecting Data Store Solution

Data Type	Used For...	Examples	Options in Azure
Relational	Structured data	Items in store, demographic data	Azure SQL, MySQL, PostgreSQL
NoSQL	Semi-structured data	Reviews, Log records, when flexibility is required	Cosmos DB (with SQL, Mongo, Azure Table API)
Graph	Data representing relationships	Family tree	Cosmos DB (with Gremlin API)
Blob	Files, videos, docs	Items' photos	Azure Blob Storage