

Managing Networking

- Assigning static hostname to System
- Introducing basic networking concepts
- Introducing NetworkManager and tools
- Configuring IPv4 address on ethernet interface
- Configuring static route
- Configuring hostname resolution
- Configuring IPv6 address on ethernet interface
- Configuring network services to start automatically at boot
- Restrict network access using firewall-cmd/firewall (Will be covered in 'Managing Security' section)

- Assign static hostname `system.example.com` to System machine.

Command	Action/Description
<code>hostnamectl</code> or <code>hostname</code>	To display current hostname assigned to System
<code>hostnamectl hostname system.example.com</code>	To assign new hostnames(static,transient,pretty) to System
<code>man hostnamectl</code>	To check manual page for hostnamectl
<code>systemctl status systemd-hostnamed.service</code>	To check status of service

Note: It is also possible to set static hostname in `/etc/hostname` file. Set hostname in file and the reboot System but I suggest to use **'hostnamectl'** utility for this task.

Introducing Basic Networking Concepts

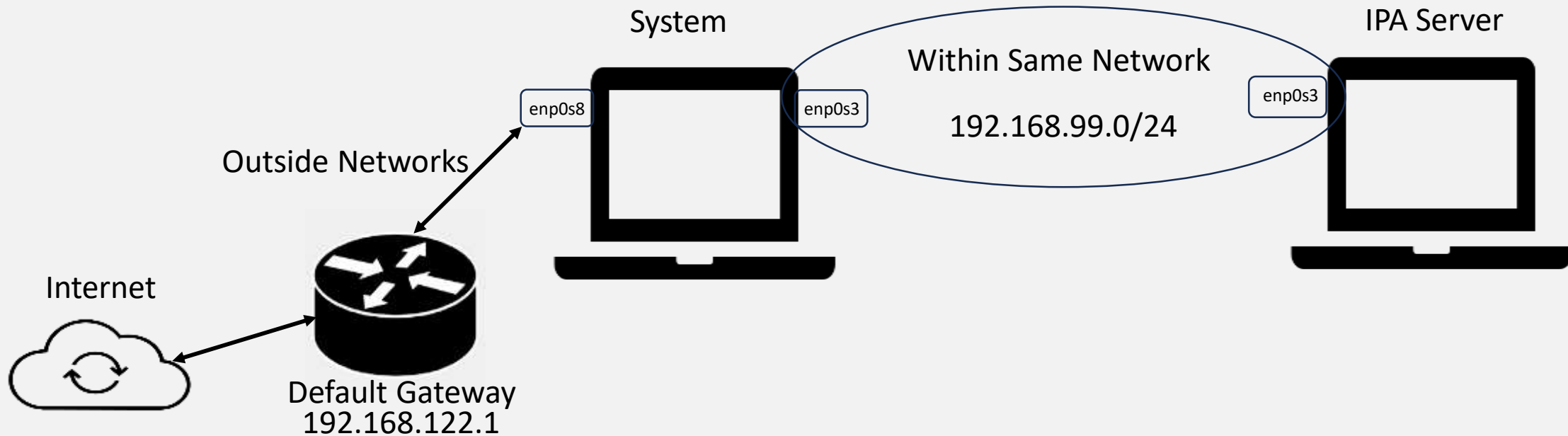

```
[root@system ~]# ip route show
default via 192.168.99.1 dev enp0s3 proto dhcp src 192.168.99.4 metric 100
default via 192.168.122.1 dev enp0s8 proto dhcp src 192.168.122.5 metric 101
192.168.99.0/24 dev enp0s3 proto kernel scope link src 192.168.99.4 metric 100
192.168.122.0/24 dev enp0s8 proto kernel scope link src 192.168.122.5 metric 101
```

Introducing NetworkManager and Tools

NetworkManager is default network manager service in **RHEL-9** and **network.service** has been removed in **RHEL-9** which was deprecated in **RHEL-8** but it was possible to use **network.service** and **network scripts** in **RHEL-8**.

NetworkManager, which is a dynamic network control and configuration daemon to keep network devices and connections up and active when they are available.

Network Manager offers management through different tools:

- **nmcli** - Network Manager command line interface
- **nmtui** - Network Manager Text user interface
- **nm-connection-editor** - Graphical User Interface

Until RHEL-8 , Network configurations are stored at path **/etc/sysconfig/network-scripts/** in the **ifcfg** format.

Starting with RHEL 9.0, NetworkManager stores network configurations at **/etc/NetworkManager/system-connections/** in a key file format.

ifcfg format :

more /etc/sysconfig/network-scripts/ifcfg-enp0s3

```
DEVICE=enp10s3
BOOTPROTO=none
ONBOOT=yes
PREFIX=24
IPADDR=192.168.99.10
```

Keyfile format :

more /etc/NetworkManager/system-connections/enp0s3.nmconnection

```
[connection]
```

```
id=example_connection
```

```
uuid=82c6272d-1ff7-4d56-9c7c-0eb27c300029
```

```
type=ethernet
```

```
autoconnect=true
```

```
[ipv4]
```

```
method=auto
```

```
[ipv6]
```

```
method=auto
```

```
[ethernet]
```

```
mac-address=00:53:00:8f:fa:66
```

- Configure IPv4 Address 192.168.99.10 on ethernet interface enp0s3 on system.example.com and set the DNS IP Address as 192.168.99.254.
 - Configure the Default Gateway as 192.168.99.1 as part of this connection.
 - IP assigned must be static.

Command	Action/Description
nmcli connection show	To display existing connections configured on different interfaces
ip address show	To display existing connections with configured IP Address(s)
nmcli connection add con-name system type ethernet ifname enp0s3 ipv4.addresses 192.168.99.10/24 ipv4.gateway 192.168.99.1	To configure ethernet interface with IPv4 Address and Gateway IP Address
nmcli connection modify system ipv4.dns 192.168.99.254 ipv4.method manual	To configure DNS IP Address for connection and make connection static
nmcli connection up system	To activate connection
systemctl restart NetworkManager	To restart network service
more /etc/resolv.conf	To verify DNS IP Address
cd /etc/NetworkManager/system-connections/	Location of Connection profile file system.nmconnection
man nmcli and man nmcli-examples	Manual pages for nmcli and nmcli-examples

- Configure static route on system.example.com for destination 10.1.1.0/24 via 192.168.99.30.
 - Route configuration must be persistent after reboot.
 - enp0s3 interface should be used as exit interface

Command	Action/Description
ip route add 10.1.1.0/24 via 192.168.99.30	Adding static route in runtime
ip route show or route -n	To display route(s)
nmcli connection modify system ipv4.routes "10.1.1.0/24 192.168.99.30"	To add persistent route using command line
nmcli connection up system	To restart/activate connection

- Configure hostname resolution for host `system1.example.com` using `hosts` file.
 - Set the `hosts` file as priority for hostname resolution in `nsswitch.conf` file.
 - Test if hostname resolution is working fine.

Command	Action/Description
<code>vim /etc/hosts</code> <code>192.168.99.50 system1.example.com</code> <code>:wq</code>	To add entry in <code>hosts</code> file
<code>getent hosts system1.example.com</code>	To verify hostname resolution is working fine

- Configure enp0s3 interface with ipv6 address 2020::1/64.
- Already existing IPv4 network configurations should not be impacted.

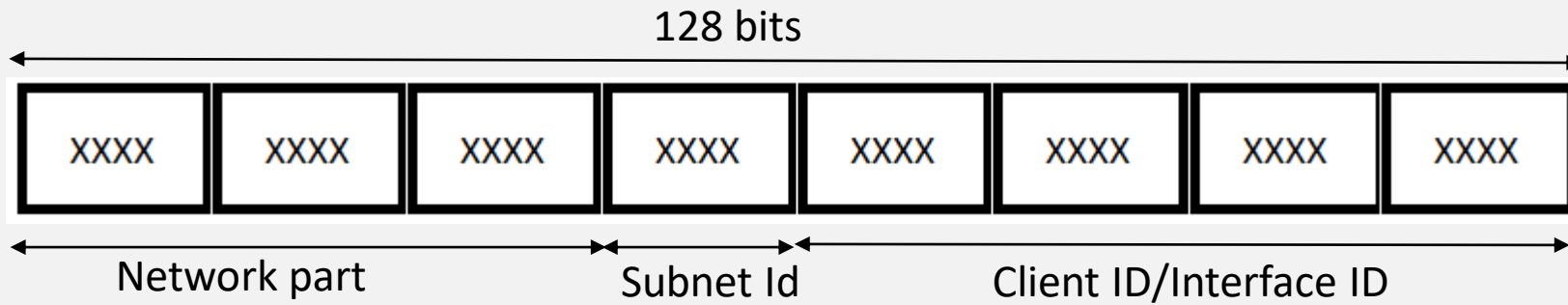

2020:0000:0000:0000:0000:0000:0000:0001/64 → 2020::1/64

Command	Action/Description
nmcli connection modify system ipv6.addresses 2020::1/64 ipv6.method manual	Configuring ipv6 on ethernet interface
nmcli connection up system	To restart/activate connection
ip address show	To display IP Address configurations
nmcli connection show system	To display connection information
man nmcli	To display Manual page for nmcli
man nmcli-examples	To display Manual page for nmcli-examples