

CCNA

Static Routing

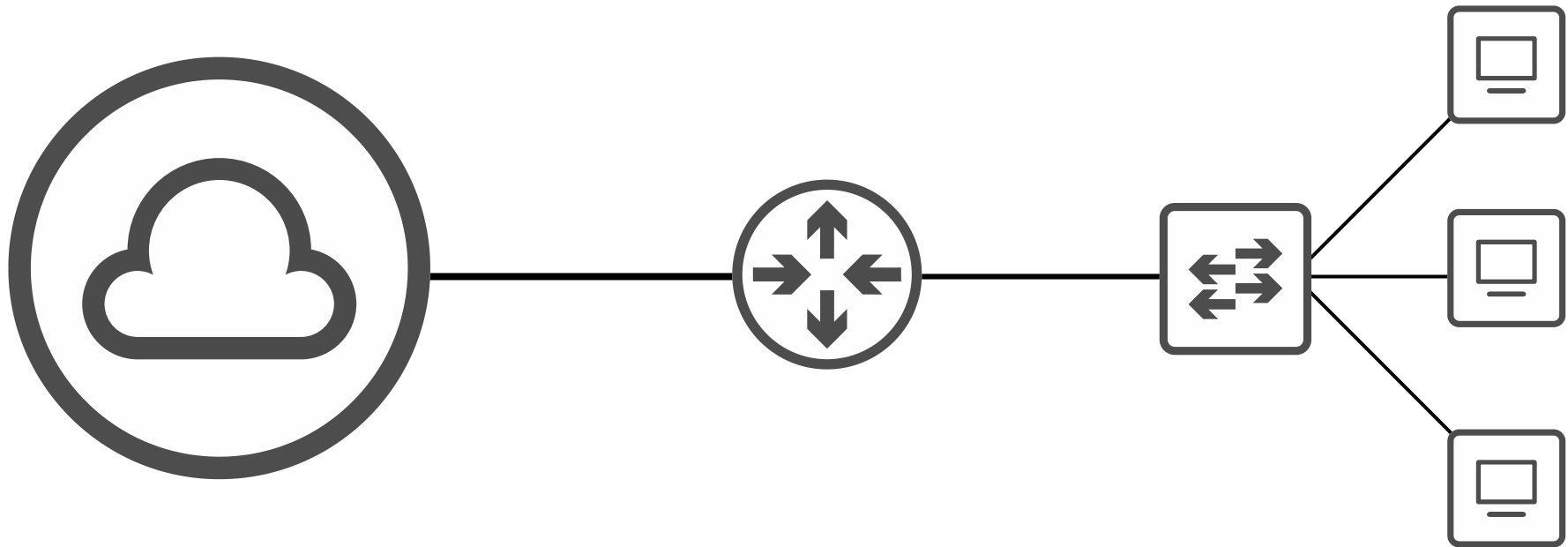

- Review: **Connected** and **Local** routes
- Intro to Static Routes
- Static Route configuration
- Default Routes

R2 Connected & Local Routes

```
R2# conf t
R2(config)# interface g0/0
R2(config-if)# ip address 192.168.12.2 255.255.255.0
R2(config-if)# no shutdown
R2(config-if)# interface g0/1
R2(config-if)# ip address 192.168.24.2 255.255.255.0
R2(config-if)# no shutdown
```

```
R2# show ip route
!codes output omitted
```

```
192.168.12.0/24 is variably subnetted, 2 subnets, 2 masks
C    192.168.12.0/24 is directly connected, GigabitEthernet0/0
L    192.168.12.2/32 is directly connected, GigabitEthernet0/0
192.168.24.0/24 is variably subnetted, 2 subnets, 2 masks
C    192.168.24.0/24 is directly connected, GigabitEthernet0/1
L    192.168.24.2/32 is directly connected, GigabitEthernet0/1
```

The following routes are automatically added to the routing table for each interface with an IP address configured:

- **C - Connected**
→ A route to the network the interface is connected to. (with the actual netmask configured on the interface)
- **L - Local**
→ A route to the actual IP address configured on the interface. (with a /32 netmask)

R2 knows how to reach its own IP addresses and destinations in its connected networks, but it doesn't know how to reach destinations in remote networks.

Knows:

192.168.12.0/24 (incl. 192.168.12.2/32)
192.168.24.0/24 (incl. 192.168.24.2/32)

Doesn't know:

192.168.1.0/24
192.168.4.0/24
192.168.13.0/24
192.168.34.0/24

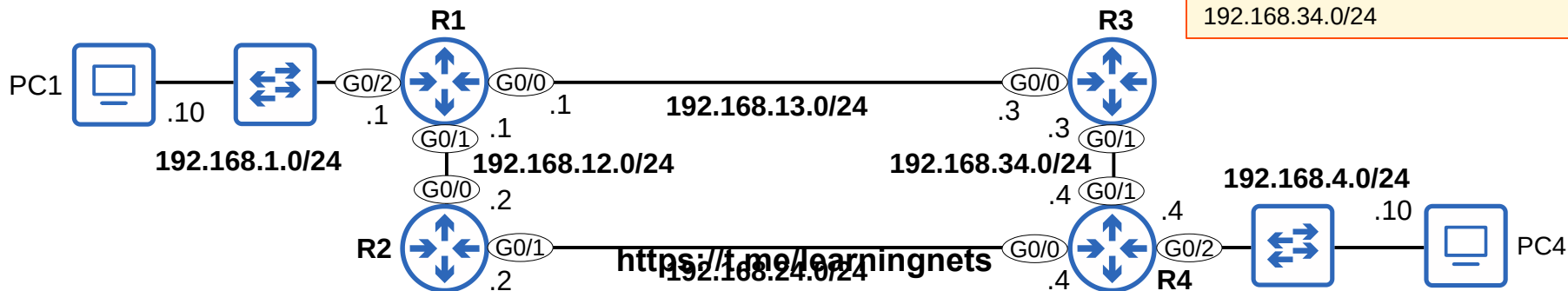

R3 Connected & Local Routes

```
R3# conf t
R3(config)# interface g0/0
R3(config-if)# ip address 192.168.13.3 255.255.255.0
R3(config-if)# no shutdown
R3(config-if)# interface g0/1
R3(config-if)# ip address 192.168.34.3 255.255.255.0
R3(config-if)# no shutdown
```

```
R3# show ip route
!codes output omitted
```

```

192.168.13.0/24 is variably subnetted, 2 subnets, 2 masks
C   192.168.13.0/24 is directly connected, GigabitEthernet0/0
L   192.168.13.3/32 is directly connected, GigabitEthernet0/0
192.168.34.0/24 is variably subnetted, 2 subnets, 2 masks
C   192.168.34.0/24 is directly connected, GigabitEthernet0/1
L   192.168.34.3/32 is directly connected, GigabitEthernet0/1

```

R3 knows how to reach its own IP addresses and destinations in its connected networks, but it doesn't know how to reach destinations in remote networks.

Knows:

192.168.13.0/24 (incl. 192.168.13.3/32)
192.168.34.0/24 (incl. 192.168.34.3/32)

Doesn't know:

192.168.1.0/24
192.168.4.0/24
192.168.12.0/24
192.168.24.0/24

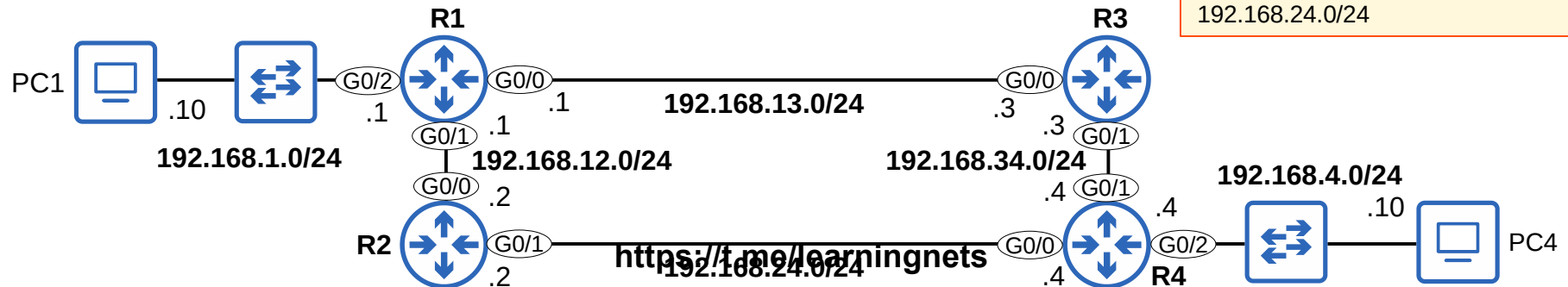

R4 Connected & Local Routes

```
R4(config)# interface g0/0
R4(config-if)# ip address 192.168.24.4 255.255.255.0
R4(config-if)# no shutdown
R4(config-if)# interface g0/1
R4(config-if)# ip address 192.168.34.4 255.255.255.0
R4(config-if)# no shutdown
R4(config-if)# interface g0/2
R4(config-if)# ip address 192.168.4.4 255.255.255.0
R4(config-if)# no shutdown
```

R4# show ip route

!codes output omitted

```
192.168.4.0/24 is variably subnetted, 2 subnets, 2 masks
C    192.168.4.0/24 is directly connected, GigabitEthernet0/2
L    192.168.4.4/32 is directly connected, GigabitEthernet0/2
192.168.24.0/24 is variably subnetted, 2 subnets, 2 masks
C    192.168.24.0/24 is directly connected, GigabitEthernet0/0
L    192.168.24.4/32 is directly connected, GigabitEthernet0/0
192.168.34.0/24 is variably subnetted, 2 subnets, 2 masks
C    192.168.34.0/24 is directly connected, GigabitEthernet0/1
L    192.168.34.4/32 is directly connected, GigabitEthernet0/1
```

R4 knows how to reach its own IP addresses and destinations in its connected networks, but it doesn't know how to reach destinations in remote networks.

Knows:

- 192.168.4.0/24 (incl. 192.168.4.4/32)
- 192.168.24.0/24 (incl. 192.168.24.4/32)
- 192.168.34.0/24 (incl. 192.168.34.4/32)

Doesn't know:

- 192.168.1.0/24
- 192.168.12.0/24
- 192.168.13.0/24

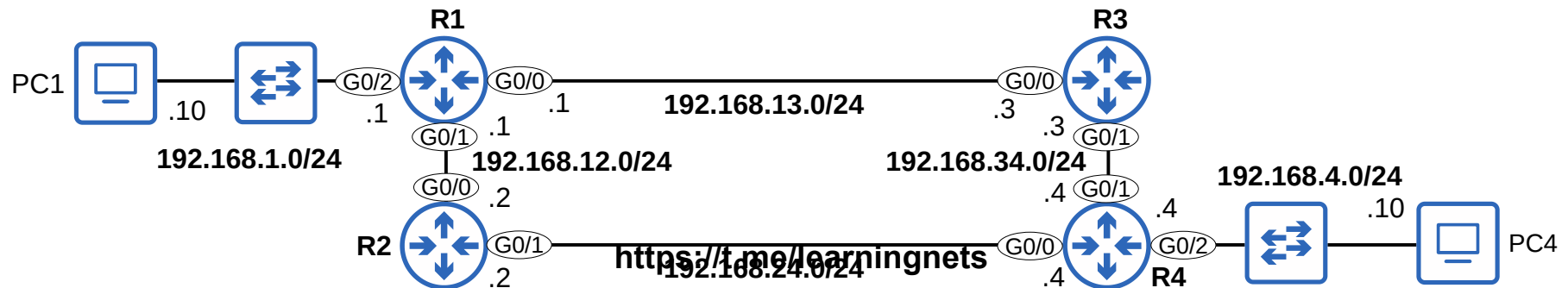

Routing Packets: Default Gateway

- End hosts like PC1 and PC4 can send packets directly to destinations in their connected network.
→ PC1 is connected to 192.168.1.0/24, PC4 is connected to 192.168.4.0/24.
- To send packets to destinations outside of their local network, they must send the packets to their **default gateway**.

PC1 (Linux) Config:

```

iface eth0 inet static
    address 192.168.1.10/24
    gateway 192.168.1.1
    
```

PC4 (Linux) Config:

```

iface eth0 inet static
    address 192.168.4.10/24
    gateway 192.168.4.4
    
```

- The **default gateway** configuration is also called a **default route**.
→ It is a route to 0.0.0.0/0 = all netmask bits set to 0. Includes all addresses from 0.0.0.0 to 255.255.255.255.
- End hosts usually have no need for any more specific routes.
→ They just need to know: to send packets outside of my local network, I should send them to my default gateway.

Src. IP: 192.168.1.10
 Dst. IP: 192.168.4.10
 Dst. MAC: R1 G0/2 MAC
 Src. MAC: PC1 eth0 MAC

*to learn R1 G0/2's MAC address, PC1 will first send an ARP request to 192.168.1.1.

The **default route** is the *least specific* route possible, because it includes all IP addresses.
0.0.0.0/0 = 4,294,967,296 IP addresses
 A /32 route (ie. Local route) is the *most specific* route possible, because it specifies only one IP address.
192.168.1.1/32 = 1 IP address

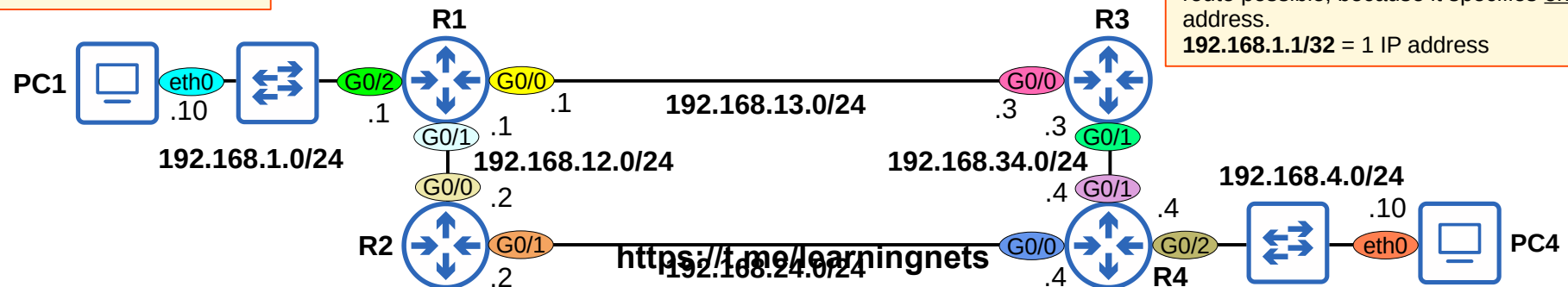

Routing Packets: Static Routes

- When R1 receives the frame from PC1, it will de-encapsulate it (remove L2 header/trailer) and look at the inside packet.
- It will check the routing table for the most-specific matching route:
- R1 has no matching routes in its routing table.
 - It will drop the packet.
- To properly forward the packet, R1 needs a route to the destination network (192.168.4.0/24).
 - Routes are instructions: *To send a packet to destinations in network 192.168.4.0/24, forward the packet to next hop Y.*

```

192.168.1.0/24 is variably subnetted, 2 subnets, 2 masks
C   192.168.1.0/24 is directly connected, GigabitEthernet0/2
L   192.168.1.1/32 is directly connected, GigabitEthernet0/2
192.168.12.0/24 is variably subnetted, 2 subnets, 2 masks
C   192.168.12.0/24 is directly connected, GigabitEthernet0/1
L   192.168.12.1/32 is directly connected, GigabitEthernet0/1
192.168.13.0/24 is variably subnetted, 2 subnets, 2 masks
C   192.168.13.0/24 is directly connected, GigabitEthernet0/0
L   192.168.13.1/32 is directly connected, GigabitEthernet0/0
  
```

- There are two possible path packets from PC1 to PC4 can take:
 - 1) PC1 → R1 → R3 → R4 → PC4
 - 2) PC1 → R1 → R2 → R4 → PC4
- In this video, we will use the path via R3, not the path via R2.

It is possible to configure the routers to:

- load-balance between path 1) and 2)
- Use path 1) as the main path and path 2) as a backup path

You will learn about these techniques later in the course.

Src. IP: ~~192.168.1.10~~
 Dst. IP: ~~192.168.4.10~~

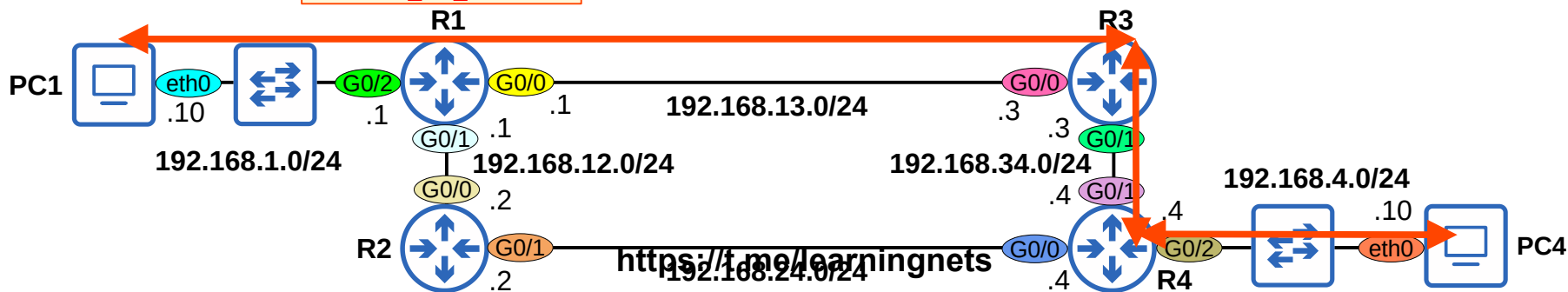

Static Route Configuration

- Each router in the path needs two routes: a route to 192.168.1.0/24 and a route to 192.168.4.0/24.
→ This ensures **two-way reachability** (PC1 can send packets to PC4, PC4 can send packets to PC1).
- R1 already has a **Connected route** to 192.168.1.0/24. R4 already has a **Connected route** to 192.168.4.0/24.
→ The other routes must be manually configured (using **Static routes**).

*routers don't need routes to all networks in the path to the destination.
→ R1 doesn't need a route to 192.168.34.0/24.
→ R4 doesn't need a route to 192.168.13.0/24.

- To allow PC1 and PC4 to communicate with each other over the network, let's configure these **Static routes** on R1, R3, and R4.

Router	Destination	Next-Hop
R1	192.168.1.0/24	Connected
	192.168.4.0/24	?
R3	192.168.1.0/24	?
	192.168.4.0/24	?
R4	192.168.1.0/24	?
	192.168.4.0/24	Connected

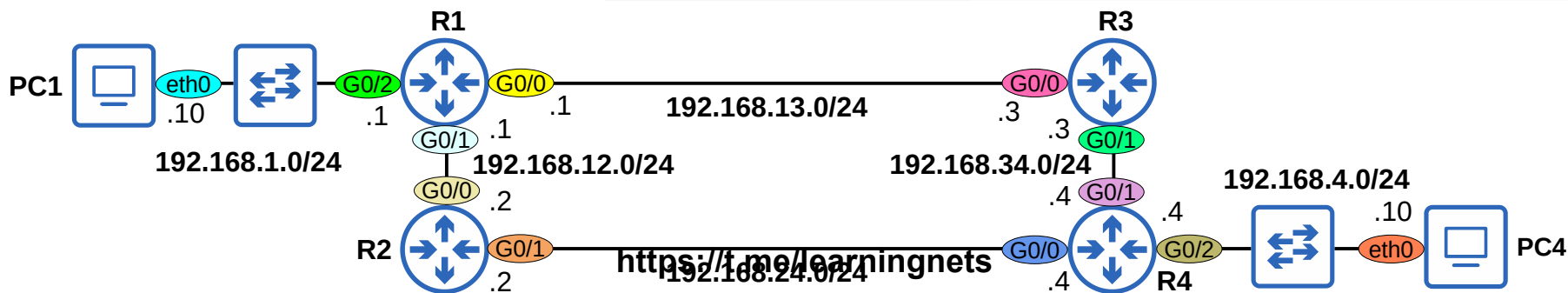

Static Route Configuration (R1)

```
R1(config)# ip route 192.168.4.0 255.255.255.0 192.168.13.3
```

```
R1(config)# ip route ip-address netmask next-hop
```

```
R1(config)# do show ip route
```

```
Codes: L - local, C - connected, S - static, R - RIP, M - mobile, B - BGP
       D - EIGRP, EX - EIGRP external, O - OSPF, IA - OSPF inter area
       N1 - OSPF NSSA external type 1, N2 - OSPF NSSA external type 2
       E1 - OSPF external type 1, E2 - OSPF external type 2
```

!some code output omitted

Gateway of last resort is not set

```
192.168.1.0/24 is variably subnetted, 2 subnets, 2 masks
C       192.168.1.0/24 is directly connected, GigabitEthernet0/2
L       192.168.1.1/32 is directly connected, GigabitEthernet0/2
S       192.168.4.0/24 [1/0] via 192.168.13.3
192.168.12.0/24 is variably subnetted, 2 subnets, 2 masks
C       192.168.12.0/24 is directly connected, GigabitEthernet0/1
L       192.168.12.1/32 is directly connected, GigabitEthernet0/1
192.168.13.0/24 is variably subnetted, 2 subnets, 2 masks
C       192.168.13.0/24 is directly connected, GigabitEthernet0/0
L       192.168.13.1/32 is directly connected, GigabitEthernet0/0
```

The [1/0] displayed in static routes means:
[Administrative Distance/Metric]
 We will cover these concepts later in the course.

Router	Destination	Next-Hop
R1	192.168.1.0/24	Connected
	192.168.4.0/24	192.168.13.3
R3	192.168.1.0/24	192.168.13.1
	192.168.4.0/24	192.168.34.4
R4	192.168.1.0/24	192.168.34.3
	192.168.4.0/24	Connected

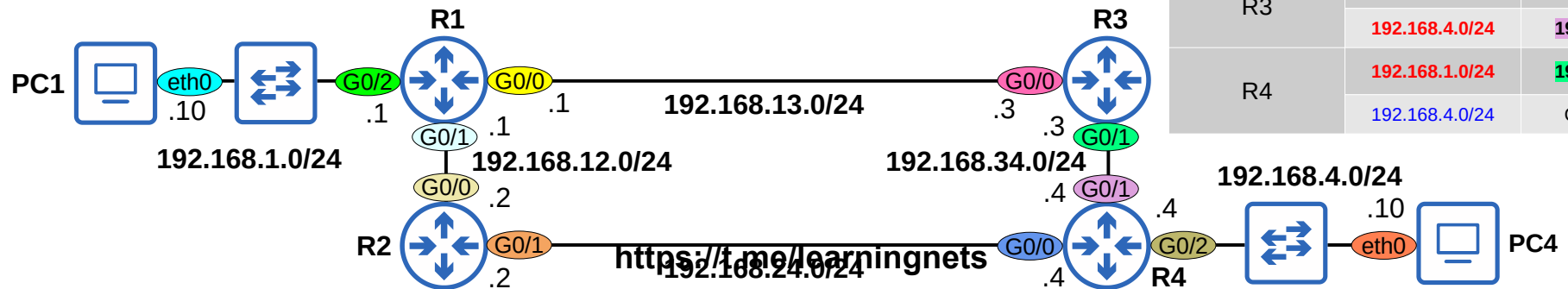

Static Route Configuration (R3)

```
R3(config)# ip route 192.168.1.0 255.255.255.0 192.168.13.1
R3(config)# ip route 192.168.4.0 255.255.255.0 192.168.34.4
```

```
R3(config)# ip route ip-address netmask next-hop
```

```
R3(config)# do show ip route
```

```
Codes: L - local, C - connected, S - static, R - RIP, M - mobile, B - BGP
       D - EIGRP, EX - EIGRP external, O - OSPF, IA - OSPF inter area
       N1 - OSPF NSSA external type 1, N2 - OSPF NSSA external type 2
       E1 - OSPF external type 1, E2 - OSPF external type 2
```

!some code output omitted

Gateway of last resort is not set

```
S    192.168.1.0/24 [1/0] via 192.168.13.1
S    192.168.4.0/24 [1/0] via 192.168.34.4
    192.168.13.0/24 is variably subnetted, 2 subnets, 2 masks
C    192.168.13.0/24 is directly connected, GigabitEthernet0/0
L    192.168.13.3/32 is directly connected, GigabitEthernet0/0
    192.168.34.0/24 is variably subnetted, 2 subnets, 2 masks
C    192.168.34.0/24 is directly connected, GigabitEthernet0/1
L    192.168.34.3/32 is directly connected, GigabitEthernet0/1
```

Router	Destination	Next-Hop
R1	192.168.1.0/24	Connected
	192.168.4.0/24	192.168.13.3
R3	192.168.1.0/24	192.168.13.1
	192.168.4.0/24	192.168.34.4
R4	192.168.1.0/24	192.168.34.3
	192.168.4.0/24	Connected

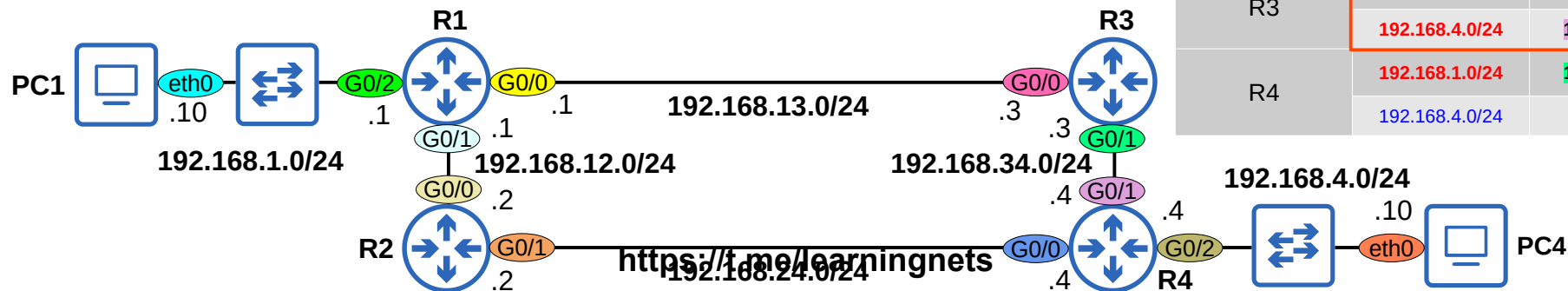

Static Route Configuration (R4)

```
R4(config)# ip route 192.168.1.0 255.255.255.0 192.168.34.3
```

```
R4(config)# ip route ip-address netmask next-hop
```

```
R4(config)# do show ip route
```

```
Codes: L - local, C - connected, S - static, R - RIP, M - mobile, B - BGP
       D - EIGRP, EX - EIGRP external, O - OSPF, IA - OSPF inter area
       N1 - OSPF NSSA external type 1, N2 - OSPF NSSA external type 2
       E1 - OSPF external type 1, E2 - OSPF external type 2
```

!some code output omitted

Gateway of last resort is not set

```
S    192.168.1.0/24 [1/0] via 192.168.34.3
    192.168.4.0/24 is variably subnetted, 2 subnets, 2 masks
C    192.168.4.0/24 is directly connected, GigabitEthernet0/2
L    192.168.4.4/32 is directly connected, GigabitEthernet0/2
    192.168.24.0/24 is variably subnetted, 2 subnets, 2 masks
C    192.168.24.0/24 is directly connected, GigabitEthernet0/0
L    192.168.24.4/32 is directly connected, GigabitEthernet0/0
    192.168.34.0/24 is variably subnetted, 2 subnets, 2 masks
C    192.168.34.0/24 is directly connected, GigabitEthernet0/1
L    192.168.34.4/32 is directly connected, GigabitEthernet0/1
```

Router	Destination	Next-Hop
R1	192.168.1.0/24	Connected
	192.168.4.0/24	192.168.13.3
R3	192.168.1.0/24	192.168.13.1
	192.168.4.0/24	192.168.34.4
R4	192.168.1.0/24	192.168.34.3
	192.168.4.0/24	Connected

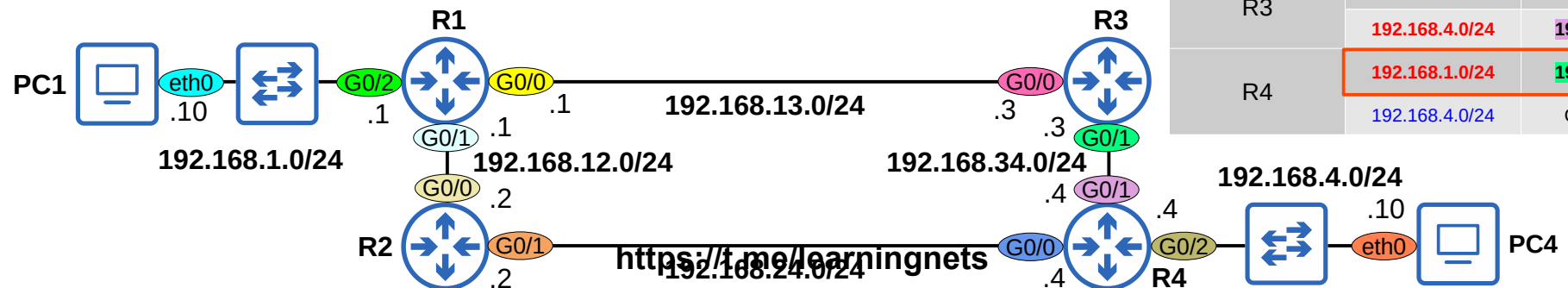

PC1 ↔ PC4

```
PC1:~$ ping 192.168.4.10
PING 192.168.4.10 (192.168.4.10): 56 data bytes
64 bytes from 192.168.4.10: seq=0 ttl=42 time=8.745 ms
64 bytes from 192.168.4.10: seq=1 ttl=42 time=4.423 ms
64 bytes from 192.168.4.10: seq=2 ttl=42 time=3.428 ms
64 bytes from 192.168.4.10: seq=3 ttl=42 time=3.544 ms
64 bytes from 192.168.4.10: seq=4 ttl=42 time=3.520 ms
^C
--- 192.168.4.10 ping statistics ---
5 packets transmitted, 5 packets received, 0% packet loss
round-trip min/avg/max = 3.428/4.732/8.745 ms
```

If the ping is successful, that means there is two-way reachability. PC1 can reach PC4, and PC4 can reach PC1.

Packet traveling from PC1 to PC4:

*we will examine this step-by-step in the “Life of a Packet” video

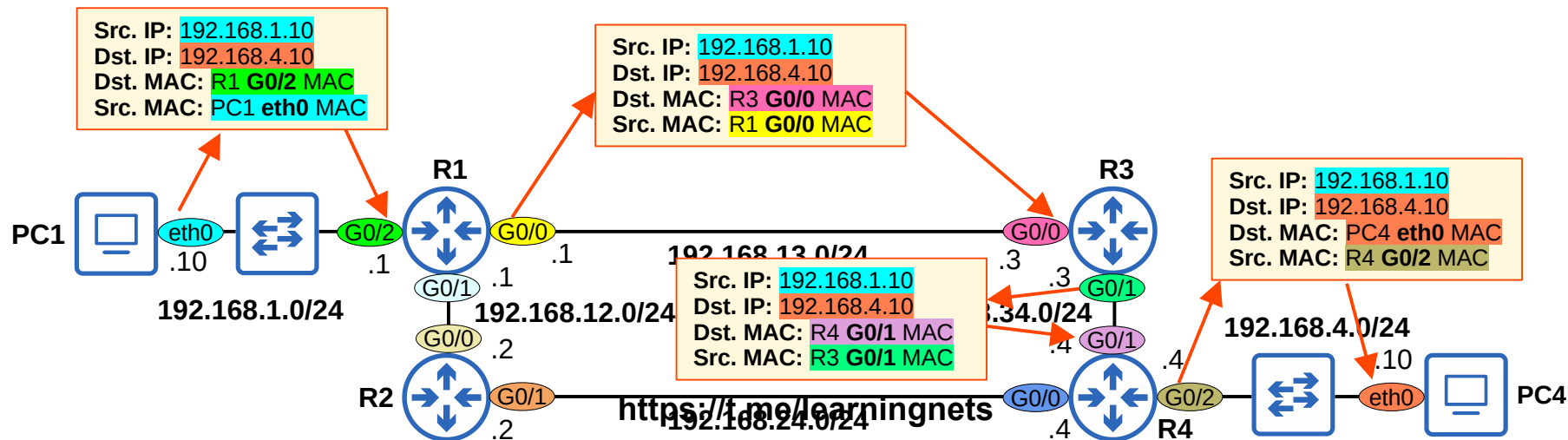

Static Route Configuration with exit-interface

```
R2(config)# ip route 192.168.1.0 255.255.255.0 g0/0
R2(config)# ip route 192.168.4.0 255.255.255.0 g0/1 192.168.24.4
```

```
R2(config)# do show ip route
```

```
Codes: L - local, C - connected, S - static, R - RIP, M - mobile, B - BGP
       D - EIGRP, EX - EIGRP external, O - OSPF, IA - OSPF inter area
       N1 - OSPF NSSA external type 1, N2 - OSPF NSSA external type 2
       E1 - OSPF external type 1, E2 - OSPF external type 2
```

!some code output omitted

Gateway of last resort is not set

```
S   192.168.1.0/24 is directly connected, GigabitEthernet0/0
S   192.168.4.0/24 [1/0] via 192.168.24.4, GigabitEthernet0/1
S   192.168.12.0/24 is variably subnetted, 2 subnets, 2 masks
C   192.168.12.0/24 is directly connected, GigabitEthernet0/0
L   192.168.12.2/32 is directly connected, GigabitEthernet0/0
S   192.168.24.0/24 is variably subnetted, 2 subnets, 2 masks
C   192.168.24.0/24 is directly connected, GigabitEthernet0/1
L   192.168.24.2/32 is directly connected, GigabitEthernet0/1
```

```
R2(config)# ip route ip-address netmask exit-interface
R2(config)# ip route ip-address netmask exit-interface next-hop
```

- Static routes in which you specify only the *exit-interface* rely on a feature called **Proxy ARP** to function.
- This is usually not a problem, but generally you can stick to *next-hop* or *exit-interface next-hop*.
- Neither is 'better' than the other: use which you prefer.

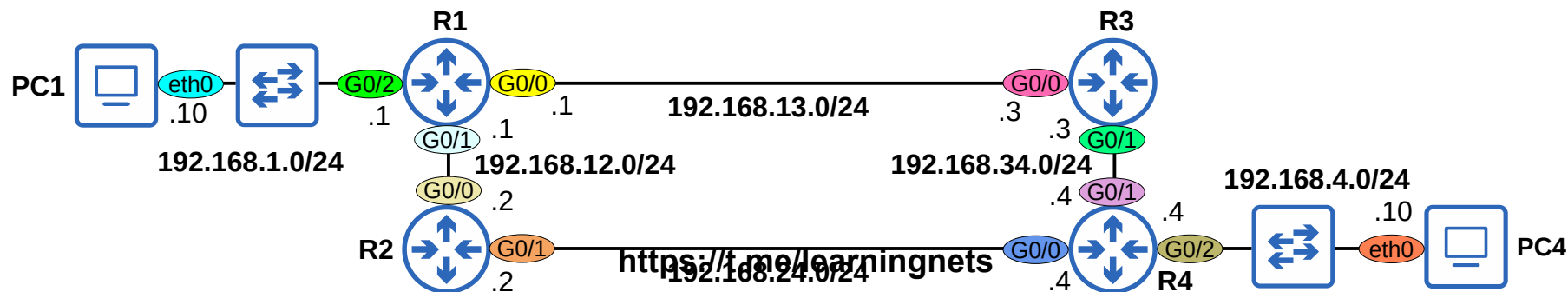

Default Route

- A **default route** is a route to 0.0.0.0/0
 - 0.0.0.0/0 is the *least specific* route possible; it includes every possible destination IP address.
- If the router doesn't have any more specific routes that match a packet's destination IP address, the router will forward the packet using the **default route**.
- A default route is often used to direct traffic to the Internet.
 - More specific routes are used for destinations in the internal corporate network.
 - Traffic to destinations outside of the internal network is sent to the Internet.

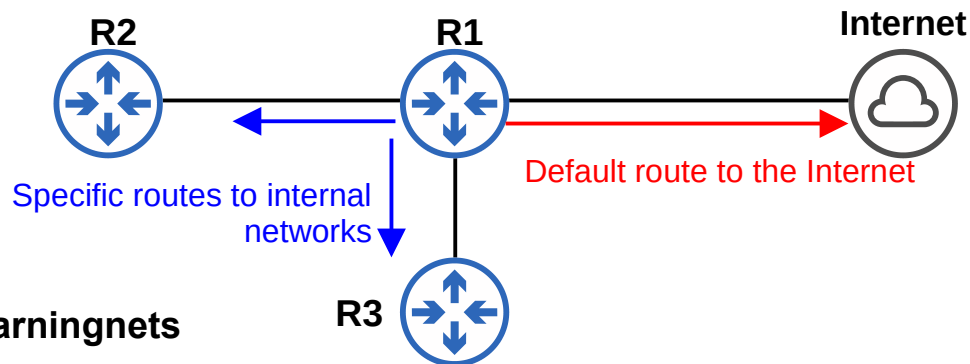

Default Route

```
R1# show ip route
```

```
!codes omitted
```

```
Gateway of last resort is not set
```

No default route has been configured yet.

```
S 10.0.0.0/8 [1/0] via 192.168.12.2
S 172.16.0.0/16 [1/0] via 192.168.13.3
192.168.12.0/24 is variably subnetted, 2 subnets, 2 masks
C 192.168.12.0/24 is directly connected, GigabitEthernet0/1
L 192.168.12.1/32 is directly connected, GigabitEthernet0/1
192.168.13.0/24 is variably subnetted, 2 subnets, 2 masks
C 192.168.13.0/24 is directly connected, GigabitEthernet0/0
L 192.168.13.1/32 is directly connected, GigabitEthernet0/0
203.0.113.0/24 is variably subnetted, 2 subnets, 2 masks
C 203.0.113.0/24 is directly connected, GigabitEthernet0/2
L 203.0.113.1/32 is directly connected, GigabitEthernet0/2
```

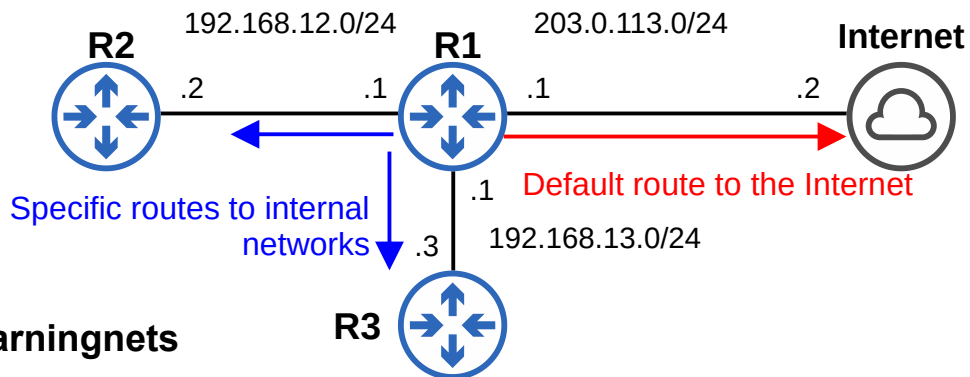

Default Route

```
R1(config)# ip route 0.0.0.0 0.0.0.0 203.0.113.2
R1(config)# do show ip route
!most codes omitted
    ia - IS-IS inter area, * - candidate default, U - per-user static route
!most codes omitted
Gateway of last resort is 203.0.113.2 to network 0.0.0.0
```

```
S* 0.0.0.0/0 [1/0] via 203.0.113.2
S 10.0.0.0/8 [1/0] via 192.168.12.2
S 172.16.0.0/16 [1/0] via 192.168.13.3
192.168.12.0/24 is variably subnetted, 2 subnets, 2 masks
C 192.168.12.0/24 is directly connected, GigabitEthernet0/1
L 192.168.12.1/32 is directly connected, GigabitEthernet0/1
192.168.13.0/24 is variably subnetted, 2 subnets, 2 masks
C 192.168.13.0/24 is directly connected, GigabitEthernet0/0
L 192.168.13.1/32 is directly connected, GigabitEthernet0/0
203.0.113.0/24 is variably subnetted, 2 subnets, 2 masks
C 203.0.113.0/24 is directly connected, GigabitEthernet0/2
L 203.0.113.1/32 is directly connected, GigabitEthernet0/2
```

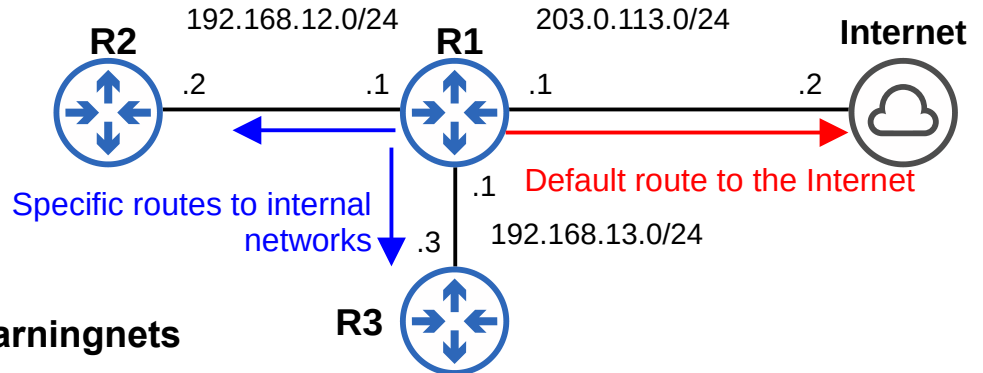

- Review: **Connected** and **Local** routes
- Intro to Static Routes
- Static Route configuration

```
R1(config)# ip route ip-address netmask next-hop
R1(config)# ip route ip-address netmask exit-interface
R1(config)# ip route ip-address netmask exit-interface next-hop
```
- Default Routes

Which of the following commands configures a default route on a Cisco router?

- a) R1(config)# ip route 0.0.0.0 0.0.0.0 10.1.1.255
- b) R1(config)# ip route 0.0.0.0/0 10.1.1.254
- c) R1(config)# ip route 0.0.0.0 255.255.255.255 10.1.1.255
- d) R1(config)# ip route 0.0.0.0/32 10.1.1.255

Quiz 2

Examine R1's routing table. Which interface will it use to forward packets destined for 8.8.8.8?

```

S*  0.0.0.0/0 [1/0] via 203.0.113.2
S    10.0.0.0/8 [1/0] via 192.168.12.2
S    172.16.0.0/16 [1/0] via 192.168.13.3
     192.168.12.0/24 is variably subnetted, 2 subnets, 2 masks
C    192.168.12.0/24 is directly connected, GigabitEthernet0/1
L    192.168.12.1/32 is directly connected, GigabitEthernet0/1
     192.168.13.0/24 is variably subnetted, 2 subnets, 2 masks
C    192.168.13.0/24 is directly connected, GigabitEthernet0/0
L    192.168.13.1/32 is directly connected, GigabitEthernet0/0
     203.0.113.0/24 is variably subnetted, 2 subnets, 2 masks
C    203.0.113.0/24 is directly connected, GigabitEthernet0/2
L    203.0.113.1/32 is directly connected, GigabitEthernet0/2
  
```

- a) GigabitEthernet0/0
- b) GigabitEthernet0/1
- c) GigabitEthernet0/2
- d) It will drop the packet.

Quiz 3

Examine the network below. Complete the graph with the static routes needed to allow PC1 and PC4 to communicate with each other.

Router	Destination	Next-Hop
R1	192.168.1.0/24	Connected
	<input data-bbox="932 458 1172 515" type="text" value="?"/>	<input data-bbox="1400 458 1640 515" type="text" value="?"/>
R2	<input data-bbox="932 539 1172 595" type="text" value="?"/>	<input data-bbox="1400 539 1640 595" type="text" value="?"/>
	<input data-bbox="932 608 1172 664" type="text" value="?"/>	<input data-bbox="1400 608 1640 664" type="text" value="?"/>
R4	<input data-bbox="932 688 1172 745" type="text" value="?"/>	<input data-bbox="1400 688 1640 745" type="text" value="?"/>
	192.168.4.0/24	Connected

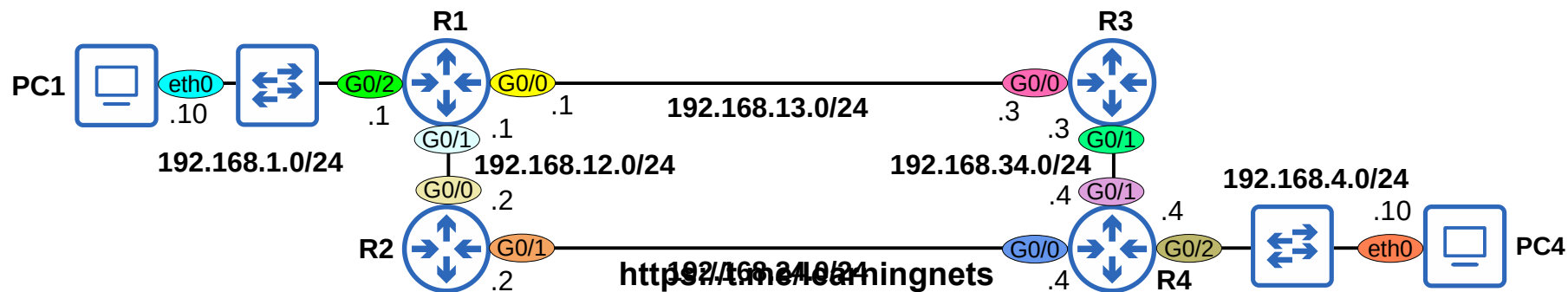

Examine the following static route in R1's routing table. What command was used to configure this route?

```
S      172.20.0.0/16 is directly connected, GigabitEthernet0/1
```

- a) R1(config)# ip route 172.20.0.0 255.255.255.0 g0/1
- b) R1(config)# interface g0/1
R1(config-if)# ip address 172.20.0.0 255.255.0.0
- c) R1(config)# ip route 172.20.0.0 255.255.255.0 g0/1 172.20.0.1
- d) R1(config)# ip route 172.20.0.0 255.255.0.0 g0/1

Quiz 5

Examine the diagram below. How many static routes would you have to configure on R3 for it to know all other destination networks shown in the diagram?

- a) One route
- b) Two routes
- c) Three routes
- d) Four routes

R3 knows how to reach its own IP addresses and destinations in its connected networks, but it doesn't know how to reach destinations in remote networks.

Knows:

192.168.13.0/24 (incl. 192.168.13.3/32)

192.168.34.0/24 (incl. 192.168.34.3/32)

Doesn't know:

192.168.1.0/24

192.168.4.0/24

192.168.12.0/24

192.168.24.0/24

