

Lab 1: Verifying License and Features in NX-OS

1. What are the commands to check licenses in NX-OS ?

Ans - show license brief, show license usage, show license

```
N5K-1# show license brief
license_FOC2114R18F_32_1.lic
license_FOC2114R18F_32_2.lic
N5K-1#

N5K-1# show license usage
Feature                               Ins  Lic  Status Expiry Date Comments
                                Count
-----
FCOE_NPV_PKG                          Yes  -   Unused never          -
FM_SERVER_PKG                          No   -   Unused          -
ENTERPRISE_PKG                         No   -   Unused          -
FC_FEATURES_PKG                        No   -   Unused          Grace 96D 7H
VMFEX_FEATURE_PKG                      Yes  -   Unused never          -
ENHANCED_LAYER2_PKG                    Yes  -   In use never     -
LAN_BASE_SERVICES_PKG                  Yes  -   In use never     -
LAN_ENTERPRISE_SERVICES_PKG            Yes  -   In use never     -
-----

N5K-1# show license
license_FOC2114R18F_32_1.lic:
SERVER this_host ANY
VENDOR cisco
INCREMENT ENHANCED_LAYER2_PKG cisco 1.0 permanent uncoun ted \
  VENDOR_STRING=<LIC_SOURCE>MDS_PRODUCTION</LIC_SOURCE><SKU>N5672-EL2-SSK9</SKU> \
  \
  HOSTID=VDH=FOC2114R18F \
  NOTICE=<LicFileID>20170419133639000</LicFileID><LicLineID>1</LicLineID><PAK>N5K
-C5672UPFOC2114R18F</PAK> \
  SIGN=E9D8510E42CA
INCREMENT LAN_BASE_SERVICES_PKG cisco 1.0 permanent uncoun ted \
  VENDOR_STRING=<LIC_SOURCE>MDS_PRODUCTION</LIC_SOURCE><SKU>N56-BAS1K9</SKU> \
  HOSTID=VDH=FOC2114R18F \
  NOTICE=<LicFileID>20170419133639000</LicFileID><LicLineID>2</LicLineID><PAK>N5K
-C5672UPFOC2114R18F</PAK> \
  SIGN=14155C8E6CD8
INCREMENT LAN_ENTERPRISE_SERVICES_PKG cisco 1.0 permanent uncoun ted \
  VENDOR_STRING=<LIC_SOURCE>MDS_PRODUCTION</LIC_SOURCE><SKU>N56-LAN1K9</SKU> \
  HOSTID=VDH=FOC2114R18F \
  NOTICE=<LicFileID>20170419133639000</LicFileID><LicLineID>3</LicLineID><PAK>N5K
-C5672UPFOC2114R18F</PAK> \
  SIGN=5459F7B41BA8
```

2. How to check the unique host id of the nexus switch?

```
N5K-1# show license host-id
License hostid: VDH=FOC2114R18F
N5K-1# █
```

3. What is the way to find the license file in bootflash directory?

Ans – License file has extension of .lic

```
N5K-1# dir bootflash: | include .lic
    927    Mar 09 09:45:20 2003  license_FOC2114R18F_32_1.lic
    _614    Mar 09 09:45:20 2003  license_FOC2114R18F_32_2.lic
```

4. What is the way to install the license?

```
N5K-1# install license bootflash:license_FOC2114R18F_32_2.lic
Installing license .....done
```

5. How to copy the license file?

```
N5K-1# copy bootflash://sup-local/license_FOC2114R18F_32_2.lic tftp://10.1.1.1/license_
FOC2114R18F_32_2.lic
Enter vrf (If no input, current vrf 'default' is considered):
Trying to connect to tftp server.....
Connection to Server Established.
```

6. How to backup the installed license files?

```
N5K-1# show license brief
license_FOC2114R18F_32_1.lic
license_FOC2114R18F_32_2.lic
N5K-1# copy licenses bootflash:LicenseAshish.tar
Backing up license done
N5K-1# dir bootflash: | include LicenseAshish.tar
    10240    Mar 09 11:38:50 2003  LicenseAshish.tar
N5K-1# copy bootflash:LicenseAshish.tar tftp://10.1.1.1/LicenseAshish.tar
Enter vrf (If no input, current vrf 'default' is considered):
Trying to connect to tftp server.....
Connection to Server Established.
```

7. How to extract the .tar file in case we want to install the licenses?

```
N5K-1# dir bootflash: | include .tar
    10240    Mar 09 11:38:50 2003  LicenseAshish.tar
    37969408  Apr 19 20:27:18 2017  n6000-uk9-kickstart.7.1.0.N1.1b.bin
    4585     Mar 13 15:15:55 2002  stary
N5K-1#
N5K-1# dir bootflash: | include .lic
N5K-1#
N5K-1# tar extract bootflash:LicenseAshish.tar
N5K-1#
N5K-1# dir bootflash: | include .lic
    927     Mar 09 09:45:20 2003  license_FOC2114R18F_32_1.lic
    _614     Mar 09 09:45:20 2003  license_FOC2114R18F_32_2.lic
```

8. How to uninstall or clear the license from the Nexus Switch?

```

N5K-1# clear license license_FOC2114R18F_32_2.lic
Clearing license license_FOC2114R18F_32_2.lic:
SERVER this_host ANY
VENDOR cisco
INCREMENT VMFEX_FEATURE_PKG cisco 1.0 permanent uncouted \
  VENDOR_STRING=<LIC_SOURCE>MDS_PRODUCTION</LIC_SOURCE><SKU>N56-VMFEX9</SKU> \
  HOSTID=VDH=FOC2114R18F \
  NOTICE=<LicFileID>2017041913370200</LicFileID><LicLineID>1</LicLineID><PAK>N5K
-c5672UPFOC2114R18F</PAK> \
  SIGN=F1F3442A7350
INCREMENT FCOE_NPV_PKG cisco 1.0 permanent uncouted \
  VENDOR_STRING=<LIC_SOURCE>MDS_PRODUCTION</LIC_SOURCE><SKU>N56-FNPV-SSK9</SKU> \
  HOSTID=VDH=FOC2114R18F \
  NOTICE=<LicFileID>2017041913370200</LicFileID><LicLineID>2</LicLineID><PAK>N5K
-c5672UPFOC2114R18F</PAK> \
  SIGN=E8BD3944217A

Do you want to continue? (y/n) y
Clearing license .....done

```

9. How to update the existing license on cisco nexus switch?

Ans - update bootflash:NEW-FILE-NAME.lic EXISTING-FILE.lic

```

N5K-1# update license bootflash:license_FOC2114R18F_32_2.lic license_FOC2114R18F_32_2.lic
Updating license_FOC2114R18F_32_2.lic:
SERVER this_host ANY
VENDOR cisco
INCREMENT VMFEX_FEATURE_PKG cisco 1.0 permanent uncouted \
  VENDOR_STRING=<LIC_SOURCE>MDS_PRODUCTION</LIC_SOURCE><SKU>N56-VMFEX9</SKU> \
  HOSTID=VDH=FOC2114R18F \
  NOTICE=<LicFileID>2017041913370200</LicFileID><LicLineID>1</LicLineID><PAK>N5K
-c5672UPFOC2114R18F</PAK> \
  SIGN=F1F3442A7350
INCREMENT FCOE_NPV_PKG cisco 1.0 permanent uncouted \
  VENDOR_STRING=<LIC_SOURCE>MDS_PRODUCTION</LIC_SOURCE><SKU>N56-FNPV-SSK9</SKU> \
  HOSTID=VDH=FOC2114R18F \
  NOTICE=<LicFileID>2017041913370200</LicFileID><LicLineID>2</LicLineID><PAK>N5K
-c5672UPFOC2114R18F</PAK> \
  SIGN=E8BD3944217A

with bootflash:/license_FOC2114R18F_32_2.lic:
SERVER this_host ANY
VENDOR cisco
INCREMENT VMFEX_FEATURE_PKG cisco 1.0 permanent uncouted \
  VENDOR_STRING=<LIC_SOURCE>MDS_PRODUCTION</LIC_SOURCE><SKU>N56-VMFEX9</SKU> \
  HOSTID=VDH=FOC2114R18F \
  NOTICE=<LicFileID>2017041913370200</LicFileID><LicLineID>1</LicLineID><PAK>N5K
-c5672UPFOC2114R18F</PAK> \
  SIGN=F1F3442A7350
INCREMENT FCOE_NPV_PKG cisco 1.0 permanent uncouted \
  VENDOR_STRING=<LIC_SOURCE>MDS_PRODUCTION</LIC_SOURCE><SKU>N56-FNPV-SSK9</SKU> \
  HOSTID=VDH=FOC2114R18F \
  NOTICE=<LicFileID>2017041913370200</LicFileID><LicLineID>2</LicLineID><PAK>N5K
-c5672UPFOC2114R18F</PAK> \
  SIGN=E8BD3944217A

Do you want to continue? (y/n) y
Updating license failed: Duplicate license
N5K-1# █

```

Here License update failed because I did not have updated license. Purpose is to show how this command runs. Once you have new updated license file, then you will see positive result.

10. How to enable grace period?

```
N5K-1# configure terminal
Enter configuration commands, one per line.  End with CNTL/Z.
N5K-1(config)# license grace-period
N5K-1(config)# end
```

11. How to verify and enable the features in NX-OS?

```
N5K-1# show feature
Feature Name                Instance  State
-----
Flexlink                    1        disabled
amt                         1        disabled
bfd                         1        disabled
bfd_app                     1        disabled
bgp                         1        enabled (not-running)
bulkstat                    1        disabled
cable-management           1        disabled
cts                         1        disabled
dhcp                       1        disabled
dot1x                      1        disabled
eigrp                      1        disabled
eigrp                      2        disabled
eigrp                      3        disabled
eigrp                      4        disabled
eth_port_sec               1        disabled
evb                         1        disabled
evmed                      1        disabled
fabric-access              1        disabled
fabric_mcast               1        disabled
fcoe                       1        disabled
fcoe-npv                   1        disabled
fex                        1        enabled
glbp                       1        disabled
hsrp_engine                1        enabled
http-server                1        disabled
interface-vlan             1        disabled
isis                       1        disabled
```

```

N5K-1# show feature | include interface-vlan
interface-vlan      1          disabled
N5K-1#
N5K-1# configure terminal
Enter configuration commands, one per line.  End with CNTL/Z.
N5K-1(config)# feature interface-vlan
N5K-1(config)# end
N5K-1#
N5K-1#
N5K-1# configure terminal
Enter configuration commands, one per line.  End with CNTL/Z.
N5K-1(config)# feature eigrp
N5K-1(config)# feature ospf
N5K-1(config)# end
N5K-1# show feature | include interface-vlan|eigrp|ospf
eigrp                1          enabled (not-running)
eigrp                2          enabled (not-running)
eigrp                3          enabled (not-running)
eigrp                4          enabled (not-running)
interface-vlan      1          enabled
ospf                 1          enabled
ospf                 2          enabled (not-running)
ospf                 3          enabled (not-running)
ospf                 4          enabled (not-running)
ospfv3               1          disabled
ospfv3               2          disabled
ospfv3               3          disabled
ospfv3               4          disabled
N5K-1# █

```

12. How to verify and enable the feature-set in NX-OS?

```

DC1-N7K-1# show feature-set
Feature Set Name      ID          State
-----
fcoe                  1          disabled
fabricpath            2          disabled
fex                   3          disabled
fabric                7          disabled
mpls                  4          disabled
DC1-N7K-1#
DC1-N7K-1# configure terminal
Enter configuration commands, one per line.  End with CNTL/Z.
DC1-N7K-1(config)# fe
feature               feature-set
DC1-N7K-1(config)# feature-set fabric
DC1-N7K-1(config)# end
DC1-N7K-1# show feature-set | i 7
fabric                7          enabled
DC1-N7K-1# █

```

Lab 2 : Basic Functions of Cisco Nexus

1. What is the command to check the interface status?

```
DC1-N7K-1# show interface status
```

```
-----  
Port                Name                Status    Vlan    Duplex  Speed  Type  
-----  
mgmt0               --                 connected routed   full    a-100  --  
Eth3/1              --                 disabled  routed   auto    auto   1000base-T  
Eth3/2              --                 disabled  1        auto    auto   1000base-T  
Eth3/3              --                 connected trunk    full    a-1000 1000base-T  
Eth3/4              --                 connected trunk    full    a-1000 1000base-T  
Eth3/5              --                 disabled  1        auto    auto   1000base-T  
Eth3/6              --                 disabled  routed   auto    auto   1000base-T  
Eth3/7              --                 connected trunk    full    a-1000 1000base-T  
Eth3/8              --                 sfpAbsent trunk    auto    auto    --  
Vlan1               --                 down      routed   auto    auto   --  
Vlan10              --                 connected routed   auto    auto   --  
Vlan16              --                 connected routed   auto    auto   --  
Vlan20              --                 connected routed   auto    auto   --  
-----
```

```
DC1-N7K-1# █
```

2. What is the command to check VRF?

```
DC1-N7K-1# show vrf
```

```
VRF-Name                VRF-ID  State  Reason  
default                  1      Up    --  
management               2      Up    --  
overlay-1                3      Up    --
```

```
DC1-N7K-1# █
```

3. How to verify whether Telnet service is enabled or disabled? Is it enabled by default? How to enable it ?

Ans: Telnet is disabled by default and SSH is enabled by default.

```
DC1-N7K-1# show feature | include telnet
```

```
telnetServer            1      disabled
```

```
DC1-N7K-1#
```

```
DC1-N7K-1# show telnet server
```

```
Telnet service is disabled
```

```
DC1-N7K-1#
```

```
DC1-N7K-1# configure terminal
```

```
Enter configuration commands, one per line. End with CNTL/Z.
```

```
DC1-N7K-1(config)# feature telnet
```

```
DC1-N7K-1(config)# end
```

```
DC1-N7K-1#
```

```
DC1-N7K-1# show feature | include telnet
```

```
telnetServer            1      enabled
```

```
DC1-N7K-1# █
```

4. How to verify SSH status? How can we check what key is being used in SSH in NX-OS?

```

N5K-1# show feature | include ssh
sshServer          1          enabled
N5K-1#
N5K-1# show ssh server
ssh version 2 is enabled
N5K-1#
N5K-1# show ssh key
*****
rsa Keys generated:Mon Nov 25 17:47:35 2002

ssh-rsa AAAAB3NzaC1yc2EAAAADAQABAAQGC6dR3wEgNrr/TBOXThIy+PPit00ULYBYP1wNNQiGDufzmA7l4
Rb++h6HwTgtJBBcXCX3JjtC1M3oczhhwYiWJkX1uE6bNZEp07wGeY/EdkuwgstgrQ5PfQ5XKM+SaRYD66bA+bMB
zu/73Pab0ZaYNgw0k54hNiQGC2PycXuFw55Q==

bitcount:1024
fingerprint:
13:1d:19:c4:7a:19:a2:db:a7:d6:4e:0f:3a:8f:58:37
*****
could not retrieve dsa key information
*****
N5K-1#

```

5. Change the SSH RSA keys from 1024 to 2048

Ans: You need to disable the SSH feature in order to change the key, later you can enable it. To be able to do so, you can either console nexus switch or do telnet. Pay attention to below command

```

N5K-1# configure terminal
Enter configuration commands, one per line. End with CNTL/Z.
N5K-1(config)# ssh key rsa 2048
rsa keys already present, use force option to overwrite them
N5K-1(config)# ssh key rsa 2048 force
deleting old rsa key.....
ssh server is enabled, cannot delete/generate the keys
N5K-1(config)# no feature ssh
XML interface to system may become unavailable since ssh is disabled
N5K-1(config)# ssh key rsa 2048 force
deleting old rsa key.....
generating rsa key(2048 bits).....
...
generated rsa key
N5K-1(config)# feature ssh
N5K-1(config)# end
N5K-1# show ssh key
*****
rsa Keys generated:Sun Mar  9 13:56:37 2003

ssh-rsa AAAAB3NzaC1yc2EAAAADAQABAAQGCucBgg7PzBikfFZWcyWrIG3dUcbW3Bu+UkwY2Stpn
1A2XTM3XX0EBMChZJuo0Bxn8W5KW8cvYJT4mfKnHhUBte7LXwiR2P5d8/RJ9HyhGtZDRdQoUT8bxNF5w
ohZ9CAG0E+IIL4mg3lkjoGErdLyza8QWkoEi4ESZUYWcS IelcBMucTqADvukLSIjuEdCmTgoeQvugwIY
T59SYRIabQGsDaLFXEcaUH4pRJ6RNaC1Z6vEIN7Ch5zeK/xQlDcbBjk51t8l7UE+AcGuNt+pf2Wj9q/h
Bah53g0kent+ln7m0c0XcRhAZBAdhyokHyX1PB8x+iQQbcwv3RXTKU5GRt

bitcount:2048
fingerprint:
a8:55:5a:45:d3:38:09:9f:31:b1:8a:fb:b5:ea:62:1c
*****
could not retrieve dsa key information
*****

```

6. How to check existing usernames created in the system? Also, create one user and show the criteria required for setting up password. Use the role "network-operator"

```

N5K-1# show user-account
user:admin
    this user account has no expiry date
    roles:network-admin
N5K-1#
N5K-1# configure terminal
Enter configuration commands, one per line. End with CNTL/Z.
N5K-1(config)# username ashish password ashish role network-operator
password is weak
Length should be at least 8 characters
N5K-1(config)# username ashish password ashishcisco role network-operator
password is weak
Password should contain characters from at least three of the following classes:
  lower case letters, upper case letters, digits and special characters.
N5K-1(config)# username ashish password Cisco@123$ role network-operator
N5K-1(config)# █

```

7. Are usernames case-sensitive? Prove it.

```

N5K-1(config)# username ashish password Cisco@123$ role network-operator
N5K-1(config)# username Ashish password Cisco@123$ role network-operator
N5K-1(config)# END
N5K-1# show user-account
user:admin
    this user account has no expiry date
    roles:network-admin
user:ashish
    this user account has no expiry date
    roles:network-operator
user:Ashish
    this user account has no expiry date
    roles:network-operator
N5K-1# █

```

8. How to check the model of the chassis?

```

N5K-1# show version | include Chassis
cisco_Nexus 5672UP Chassis ("Nexus 5672UP Supervisor")

```

9. How to check kickstart and system image running on Nexus 5K and 7K?

```

N5K-1# show version | i image
kickstart image file is: bootflash:///n6000-uk9-kickstart.7.1.0.N1.1b.bin
system image file is:    bootflash:///n6000-uk9.7.1.0.N1.1b.bin
DC1-N7K-1# show ver | i image
kickstart image file is: bootflash:///n7000-s2-kickstart.8.0.1.bin
system image file is:    bootflash:///n7000-s2-dk9.8.0.1.bin

```

10. How to save the configuration on Nexus Switches?

Ans - The only way is to use "copy run start" command. Here "write memory" does not work

```
DC1-N7K-1# copy running-config startup-config
[#####] 100%
Copy complete.
```

```
N5K-1# copy running-config startup-config
[#####] 100%
Copy complete, now saving to disk (please wait)...
```

11. Does “Write memory” work?

```
N5K-1# write memory
      ^
% Invalid command at '^' marker.
```

12. How to view the current and saved configuration on Nexus?

Ans : Command is same as traditional switches

```
N5K-1# show running-config
```

```
N5K-1# show startup-config
```

13. How to erase the startup configuration?

```
N5K-1# write erase
Warning: This command will erase the startup-configuration.
Do you wish to proceed anyway? (y/n) [n]
```

14. What are the spanning-tree modes supported in NX-OS?

```
N5K-1(config)# spanning-tree mode ?
  mst           Multiple spanning tree mode
  rapid-pvst    Per-Vlan spanning tree mode
```

```
DC1-N7K-1(config)# spanning-tree mode ?
  mst           Multiple spanning tree mode
  rapid-pvst    Per-Vlan spanning tree mode
```

15. How to setup “exec-timeout” and limit “max-sessions” on Nexus 5k and 7k switches?

```
N5K-1(config)# line vty
N5K-1(config-line)# exec-timeout ?
  <0-525600> Enter timeout in minutes, 0 to disable
```

```
N5K-1(config-line)# session-limit ?
  <1-64> Max concurrent vsh sessions
```

```
DC1-N7K-1(config)# line vty
DC1-N7K-1(config-line)# exec-timeout ?
  <0-525600> Enter timeout in minutes, 0 to disable
```

```
DC1-N7K-1(config-line)# session-limit ?
  <1-64> Max concurrent vsh sessions
```

16. Do we need to use the “do” command in configuration mode to run the commands of privilege mode?

Ans : It is not required.

```
DC1-N7K-1# configure terminal
Enter configuration commands, one per line. End with CNTL/Z.
DC1-N7K-1(config)# show feature | include interface-vlan
interface-vlan      1      enabled
```

However, “do” command works as well.

```
DC1-N7K-1(config)# do show feature | include interface-vlan
interface-vlan      1      enabled
```

17. What is the way to reload nexus switch?

```
N5K-1# reload ?
  <CR>
  all           Reboot the entire box and Fex Modules
  fex           Reboot Fex
  power-cycle   Power cycle ADM

N5K-1# reload all
WARNING: There is unsaved configuration!!!
WARNING: This command will reboot the system and all FEX modules
Do you want to continue? (y/n) [n]
```

Lab 3 : Port Profiles in NX-OS

1. What is the first step in creating port-profile?

Ans : Define the “port-profile type” else default type will be set to “ethernet”.

```
N5K-1(config)# port-profile Ashish
N5K-1(config-port-prof)# end
N5K-1#

N5K-1(config)# port-profile type interface-vlan Ashish
ERROR: Changing type of an existing profile is not allowed.Profile Ashish type Ethernet, requested type
```

```
N5K-1# show port-profile brief
```

Port Profile	Profile Type	Profile State	Conf Items	Eval Items	Assigned Intfs	Child Profs
ABC	Interface-vlan	0	0	0	0	0
Ashish	Ethernet	0	0	0	0	0

Profile Type	Total Intfs

```
N5K-1# show port-profile name Ashish
```

```
SHOW PORT_PROFILE
```

```
port-profile Ashish
  type: Ethernet
  description:
  status: disabled
  max-ports: 512
  inherit:
  config attributes:
  evaluated config attributes:
  assigned interfaces:
```

2. How to activate Port-Profile in NX-OS?

```
N5K-1# configure terminal
```

```
Enter configuration commands, one per line. End with CNTL/Z.
```

```
N5K-1(config)# port-profile type ethernet Ashish
```

```
N5K-1(config-port-prof)# state enabled
```

```
N5K-1(config-port-prof)# end
```

```
N5K-1# show port-profile name Ashish | include status
```

```
status: enabled
```

3. Enter the commands you want to configure in Port-Profile named "Ashish"

```
N5K-1# configure terminal
```

```
Enter configuration commands, one per line. End with CNTL/Z.
```

```
N5K-1(config)# port-profile type ethernet Ashish
```

```
N5K-1(config-port-prof)# state enabled
```

```
N5K-1(config-port-prof)# switchport mode access
```

```
N5K-1(config-port-prof)# switchport access vlan 100
```

```
N5K-1(config-port-prof)# shutdown
```

```
N5K-1(config-port-prof)# exit
```

```
N5K-1(config)#
```

4. How to attach the Port-Profile to the Interfaces?

```
N5K-1# configure terminal
```

```
Enter configuration commands, one per line. End with CNTL/Z.
```

```
N5K-1(config)# interface ethernet 1/2, ethernet 1/4
```

```
N5K-1(config-if-range)# inherit port-profile Ashish
```

```
N5K-1(config-if-range)# end
```

5. How to verify if the Interfaces received the configuration or not?

```

N5K-1# show run interface ethernet 1/2 , ethernet 1/4

!Command: show running-config interface Ethernet1/2, Ethernet1/4
!Time: Sun Mar 16 12:34:49 2003

version 7.1(0)N1(1b)

interface Ethernet1/2
  inherit port-profile Ashish

interface Ethernet1/4
  inherit port-profile Ashish

N5K-1#
N5K-1# show port-profile expand-interface name Ashish

```

```

port-profile Ashish
 Ethernet1/2
   switchport access vlan 100
   shutdown
 Ethernet1/4
   switchport access vlan 100
   shutdown

```

6. Is Port-Profile Event Driven?

Before

```

N5K-1# show interface ethernet 1/2 , ethernet 1/4 | include down
Ethernet1/2 is down (Administratively down)
  0 watchdog 0 bad etype drop 0 bad proto drop 0 if down drop
Ethernet1/4 is down (Administratively down)
  0 watchdog 0 bad etype drop 0 bad proto drop 0 if down drop

```

After making changes in port-profile, you will see that command is run immediately

```

V5K-1# configure terminal
Enter configuration commands, one per line. End with CNTL/Z.
V5K-1(config)# port-profile type ethernet Ashish
V5K-1(config-port-prof)# no shutdown
V5K-1(config-port-prof)# end
V5K-1# show interface ethernet 1/2 , ethernet 1/4 | i Ethernet1/2|Ethernet1/4
Ethernet1/2 is down (Link not connected)
Ethernet1/4 is up

```

7. How to change the Port-Profile Type?

Ans : You can not edit the "port-profile type". You can delete the file and recreate it.

```

N5K-1# configure terminal
Enter configuration commands, one per line. End with CNTL/Z.
N5K-1(config)# port-profile type interface-vlan Ashish
ERROR: Changing type of an existing profile is not allowed.Profile Ashish type Ethernet, requested type
N5K-1(config)#
N5K-1(config)# no port-profile Ashish
Warning: Profile is applied on some interfaces, continuing with delete
N5K-1(config)# port-profile type interface-vlan Ashish
N5K-1(config-port-prof)# end
N5K-1# show port-profile name Ashish

SHOW PORT_PROFILE

port-profile Ashish
  type: Interface-vlan
  description:
  status: disabled
  max-ports: 512
  inherit:
  config attributes:
  evaluated config attributes:
  assigned interfaces:

```

Lab 4 : Configuring FEX with Nexus 5k

1. What is the way to enable the FEX feature in Nexus?

```

N5K-1# configure terminal
Enter configuration commands, one per line. End with CNTL/Z.
N5K-1(config)# feature fex
N5K-1(config)# exit
N5K-1# show feature | i fex
fex                1                enabled

```

2. How to verify whether FEX module is getting discovered or not in Parent Switch?

```

N5K-1# show fex

```

FEX Number	FEX Description	FEX State	FEX Model	Fex Serial
---	---	Discovered	N2K-C2348TQ-10GE	FOC2114R2B3

3. How to check the status of the Interface connected to FEX module?

```

N5K-1# show interface ethernet 1/31 status

```

Port	Name	Status	Vlan	Duplex	Speed	Type
Eth1/31	--	FEX not c	1	full	10G	SFP-H10GB-C

4. How to configure FEX and Static Pinning?

```
N5K-1# configure terminal
Enter configuration commands, one per line. End with CNTL/Z.
N5K-1(config)# fex 100
N5K-1(config-fex)# description Ashish-FEX
N5K-1(config-fex)# pinning max-links 2
Change in Max-links will cause traffic disruption.
N5K-1(config-fex)# end
```

5. Configure the Interfaces which are connected to FEX i.e. Fabric Extender?

```
N5K-1# configure terminal
Enter configuration commands, one per line. End with CNTL/Z.
N5K-1(config)# interface ethernet 1/31
N5K-1(config-if)# no shutdown
N5K-1(config-if)# switchport mode fex-fabric
N5K-1(config-if)# fex associate 100
N5K-1(config-if)# end
N5K-1# █
```

6. Verify the FEX on Parent Switch?

```
N5K-1# show fex
```

FEX Number	FEX Description	FEX State	FEX Model	Fex Serial
100	Ashish-FEX	Online	N2K-C2348TQ-10GE	FOC2114R2B3

```
N5K-1#
```

```
N5K-1# show fex 100
```

```
FEX: 100 Description: Ashish-FEX state: Online
  FEX version: 7.1(0)N1(1b) [Switch version: 7.1(0)N1(1b)]
  Extender Serial: FOC2114R2B3
  Extender Model: N2K-C2348TQ-10GE, Part No: 73-16842-04
  Pinning-mode: static Max-links: 2
  Fabric port for control traffic: Eth1/31
  FCoE Admin: false
  FCoE Oper: true
  FCoE FEX AA Configured: false
  Fabric interface state:
    Eth1/31 - Interface Up. State: Active
```

```
N5K-1#
```

```
N5K-1# show fex 100 detail
```

```
FEX: 100 Description: Ashish-FEX state: Online
  FEX version: 7.1(0)N1(1b) [Switch version: 7.1(0)N1(1b)]
  FEX Interim version: 7.1(0)N1(1b)
  Switch Interim version: 7.1(0)N1(1b)
  Extender Serial: FOC2114R2B3
  Extender Model: N2K-C2348TQ-10GE, Part No: 73-16842-04
  Card Id: 266, Mac Addr: 00:c1:b1:d0:3a:a2, Num Macs: 64
  Module Sw Gen: 21 [Switch Sw Gen: 21]
  post level: complete
  Pinning-mode: static Max-links: 2
  Fabric port for control traffic: Eth1/31
  FCoE Admin: false
  FCoE Oper: true
  FCoE FEX AA Configured: false
  Fabric interface state:
    Eth1/31 - Interface Up. State: Active
```

Fex Port	State	Fabric Port
Eth100/1/1	Down	Eth1/31
Eth100/1/2	Down	Eth1/31
Eth100/1/3	Down	Eth1/31
Eth100/1/4	Down	Eth1/31
Eth100/1/5	Down	Eth1/31
Eth100/1/6	Down	Eth1/31
Eth100/1/7	Down	Eth1/31
Eth100/1/8	Down	Eth1/31
Eth100/1/9	Down	Eth1/31
Eth100/1/10	Down	Eth1/31
Eth100/1/11	Down	Eth1/31

7. Check the Interfaces of FEX i.e. the front panel ports.

```

V5K-1# show interface status | include Eth100/
Eth100/1/1    --          notconnec 1          auto    auto    1G/10G
Eth100/1/2    --          notconnec 1          auto    auto    1G/10G
Eth100/1/3    --          notconnec 1          auto    auto    1G/10G
Eth100/1/4    --          notconnec 1          auto    auto    1G/10G
Eth100/1/5    --          notconnec 1          auto    auto    1G/10G
Eth100/1/6    --          notconnec 1          auto    auto    1G/10G
Eth100/1/7    --          notconnec 1          auto    auto    1G/10G
Eth100/1/8    --          notconnec 1          auto    auto    1G/10G
Eth100/1/9    --          notconnec 1          auto    auto    1G/10G
Eth100/1/10   --          notconnec 1          auto    auto    1G/10G
Eth100/1/11   --          notconnec 1          auto    auto    1G/10G
Eth100/1/12   --          notconnec 1          auto    auto    1G/10G
Eth100/1/13   --          notconnec 1          auto    auto    1G/10G
Eth100/1/14   --          notconnec 1          auto    auto    1G/10G
Eth100/1/15   --          notconnec 1          auto    auto    1G/10G
Eth100/1/16   --          notconnec 1          auto    auto    1G/10G
Eth100/1/17   --          notconnec 1          auto    auto    1G/10G
Eth100/1/18   --          notconnec 1          auto    auto    1G/10G

```

8. Since the front panel ports are mapped with the Parent Switch's interfaces which connect to FEX, so what will happen if that interface goes down.

Ans – Front Panel Ports of FEX will go down.

```

N5K-1# configure terminal
Enter configuration commands, one per line.  End with CNTL/Z.
N5K-1(config)# interface ethernet 1/31
N5K-1(config-if)# shutdown
N5K-1(config-if)# end
N5K-1# show fex 100 detail
FEX: 100 Description: Ashish-FEX   state: Offline
  FEX version: 7.1(0)N1(1b) [Switch version: 7.1(0)N1(1b)]
  FEX Interim version: 7.1(0)N1(1b)
  Switch Interim version: 7.1(0)N1(1b)
  Extender Serial: FOC2114R2B3
  Extender Model: N2K-C2348TQ-10GE, Part No: 73-16842-04
  Card Id: 266, Mac Addr: 00:c1:b1:d0:3a:a2, Num Macs: 64
  Module Sw Gen: 21 [Switch Sw Gen: 21]
  post level: complete
  Pinning-mode: static   Max-links: 2
  Fabric port for control traffic:
  FCoE Admin: false
  FCoE Oper: true
  FCoE FEX AA Configured: false
  Fabric interface state:
    Eth1/31 - Interface Down. State: Configured
  Fex Port      State  Fabric Port
    Eth100/1/1  Down   Eth1/31
    Eth100/1/2  Down   Eth1/31
    Eth100/1/3  Down   Eth1/31
    Eth100/1/4  Down   Eth1/31
    Eth100/1/5  Down   Eth1/31
    Eth100/1/6  Down   Eth1/31
    Eth100/1/7  Down   Eth1/31
    Eth100/1/8  Down   Eth1/31
    Eth100/1/9  Down   Eth1/31
    Eth100/1/10 Down   Eth1/31
    Eth100/1/11 Down   Eth1/31
    Eth100/1/12 Down   Eth1/31

```

9. What is the way we can redistribute or re-map front panel port to other Interface of Parent Fex-fabric?

```

N5K-1# fex pinning redistribute 100
No redistribution needed on FEX 100
N5K-1# █

```

Above would have transferred the ownership to the other port if it was configured. So, better solution is that you use port channel with pinning as 1.

10. Now, use the port channel instead of individual interface

```
N5K-1# config terminal
Enter configuration commands, one per line.  End with CNTL/Z.
N5K-1(config)# default interface ethernet 1/31
N5K-1(config)# interface ethernet 1/31
N5K-1(config-if)# channel-group 100 mode on
N5K-1(config-if)# exit
N5K-1(config)# interface port-channel 100
N5K-1(config-if)# switchport mode fex-fabric
N5K-1(config-if)# exit
N5K-1(config)# fex 100
N5K-1(config-fex)# pinning max-links 1
Change in Max-links will cause traffic disruption.
N5K-1(config-fex)# exit
N5K-1(config)# interface port-channel 100
N5K-1(config-if)# fex associate 100
N5K-1(config-if)# end
N5K-1#
```

11. Verify whether FEX is working when we used Port channel?

```
N5K-1# show fex
FEX          FEX          FEX          FEX          Fex
Number      Description    State         Model         Serial
-----
100         Ashish-FEX    Online        N2K-C2348TQ-10GE  FOC2114R2B3
```

```
N5K-1#
```

```
N5K-1#
```

```
N5K-1# show fex 100 detail
```

```
FEX: 100 Description: Ashish-FEX  state: Online
FEX version: 7.1(0)N1(1b) [Switch version: 7.1(0)N1(1b)]
FEX Interim version: 7.1(0)N1(1b)
Switch Interim version: 7.1(0)N1(1b)
Extender Serial: FOC2114R2B3
Extender Model: N2K-C2348TQ-10GE, Part No: 73-16842-04
Card Id: 266, Mac Addr: 00:c1:b1:d0:3a:a2, Num Macs: 64
Module Sw Gen: 21 [Switch Sw Gen: 21]
post level: complete
Pinning-mode: static Max-links: 1
Fabric port for control traffic: Eth1/31
FCoE Admin: false
FCoE Oper: true
FCoE FEX AA Configured: false
Fabric interface state:
  Po100 - Interface Up. State: Active
  Eth1/31 - Interface Up. State: Active
Fex Port      State Fabric Port
Eth100/1/1    Down   Po100
Eth100/1/2    Down   Po100
Eth100/1/3    Down   Po100
Eth100/1/4    Down   Po100
Eth100/1/5    Down   Po100
Eth100/1/6    Down   Po100
Eth100/1/7    Down   Po100
Eth100/1/8    Down   Po100
Eth100/1/9    Down   Po100
Eth100/1/10   Down   Po100
Eth100/1/11   Down   Po100
```

12. Can we use max-pinning as more than one with Port-channel?

Ans – No, we can't . See below

```
N5K-1#
```

```
N5K-1# configure terminal
```

```
Enter configuration commands, one per line. End with CNTL/Z.
```

```
N5K-1(config)# fex 100
```

```
N5K-1(config-fex)# pinning max-links 2
```

```
Error: FEX has or requires port-channel. max-links should be one
```

```
N5K-1(config-fex)# end
```

13. Does LACP work while forming Ether-channel with FEX?

Ans – No. See below.

```
N5K-1(config-if)# channel-group 100 mode passive
Fabric port-channel in LACP mode is not supported
N5K-1(config-if)# channel-group 100 mode active
Fabric port-channel in LACP mode is not supported
```

14. What happens when one FEX is connected to two parent switches?

Ans - It will be managed from single parent unless we have advanced port channel configured i.e. Virtual Port-Channel aka vPC.

See this. It is working from N5K-1

```
N5K-1# show fex | i B3
100      Ashish-FEX                Online      N2K-C2348TQ-10GE  FOC2114R2B3
N5K-1# █
```

While it is struck in discovered phase on another parent switch 5K-2.

```
N5K-2# show fex
  FEX      FEX      FEX      FEX      Fex
Number  Description  State      Model      Serial
-----
  ---      -
  █          -          Discovered  N2K-C2348TQ-10GE  FOC2114R2B3
```

Lab 5 : Configuring vPC (Virtual Port Channel)

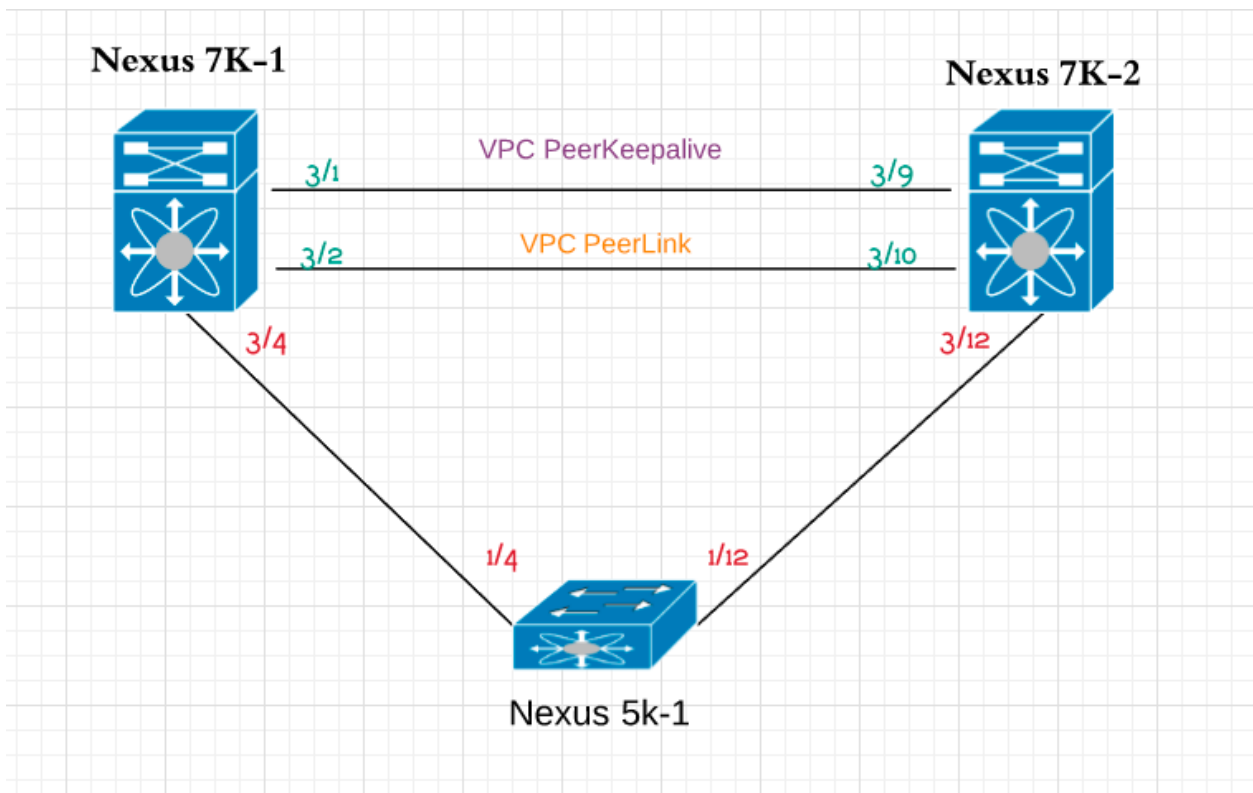

1. Enable vPC feature on Both Nexus 7K-1 and 7K-2 vPC peers.

```
DC1-N7K-1# configure terminal
Enter configuration commands, one per line. End with CNTL/Z.
DC1-N7K-1(config)# feature vpc
DC1-N7K-1(config)# end
DC1-N7K-1# █
```

```
DC1-N7K-2# configure terminal
Enter configuration commands, one per line. End with CNTL/Z.
DC1-N7K-2(config)# feature vpc
DC1-N7K-2(config)# end
DC1-N7K-2# █
```

2. Configuring VRF and management IP addresses on VPC Peers for Peer-Keepalive.

Switch N7K-1

```
DC1-N7K-1# configure terminal
Enter configuration commands, one per line.  End with CNTL/Z.
DC1-N7K-1(config)# vrf context keepalive
DC1-N7K-1(config-vrf)# exit
DC1-N7K-1(config)# interface ethernet 3/1
DC1-N7K-1(config-if)# no switchport
DC1-N7K-1(config-if)# vrf member keepalive
DC1-N7K-1(config-if)# ip address 30.1.1.1/24
DC1-N7K-1(config-if)# no shutdown
DC1-N7K-1(config-if)# end
DC1-N7K-1# show run interface ethernet 3/1
```

```
!Command: show running-config interface Ethernet3/1
!Time: Wed Jul 17 20:28:50 2019
```

```
version 8.0(1)
```

```
interface Ethernet3/1
  vrf member keepalive
  ip address 30.1.1.1/24
  no shutdown
```

```
DC1-N7K-1# show ip interface brief vrf keepalive
IP Interface Status for VRF "keepalive"(5)
Interface          IP Address      Interface Status
Eth3/1             30.1.1.1       protocol-up/link-up/admin-up
DC1-N7K-1# █
```

Switch N7K-2

```

DC1-N7K-2# configure terminal
Enter configuration commands, one per line.  End with CNTL/Z.
DC1-N7K-2(config)# vrf context keepalive
DC1-N7K-2(config-vrf)# exit
DC1-N7K-2(config)# interface ethernet 3/9
DC1-N7K-2(config-if)# no switchport
DC1-N7K-2(config-if)# vrf member keepalive
DC1-N7K-2(config-if)# ip address 30.1.1.2/24
DC1-N7K-2(config-if)# no shutdown
DC1-N7K-2(config-if)# end
DC1-N7K-2# show run interface ethernet 3/9

!Command: show running-config interface Ethernet3/9
!Time: Wed Jul 17 20:33:57 2019

version 8.0(1)

interface Ethernet3/9
  vrf member keepalive
  ip address 30.1.1.2/24
  no shutdown

DC1-N7K-2# show ip interface brief vrf keepalive
IP Interface Status for VRF "keepalive"(6)
Interface          IP Address      Interface Status
Eth3/9             30.1.1.2       protocol-up/link-up/admin-up

```

We configured **30.1.1.1** on Eth3/1 Switch N7K-1 and **30.1.1.2** on Eth3/9 Switch N7K-2

3. Test IP connectivity between vPC peer switches.

```

DC1-N7K-1# ping 30.1.1.2 vrf keepalive
PING 30.1.1.2 (30.1.1.2): 56 data bytes
64 bytes from 30.1.1.2: icmp_seq=0 ttl=254 time=1.009 ms
64 bytes from 30.1.1.2: icmp_seq=1 ttl=254 time=0.925 ms
64 bytes from 30.1.1.2: icmp_seq=2 ttl=254 time=0.903 ms
64 bytes from 30.1.1.2: icmp_seq=3 ttl=254 time=0.862 ms
64 bytes from 30.1.1.2: icmp_seq=4 ttl=254 time=0.912 ms
^C
--- 30.1.1.2 ping statistics ---
5 packets transmitted, 5 packets received, 0.00% packet loss
round-trip min/avg/max = 0.862/0.922/1.009 ms
DC1-N7K-1# █

```

```
DC1-N7K-2# ping 30.1.1.1 vrf keepalive
PING 30.1.1.1 (30.1.1.1): 56 data bytes
64 bytes from 30.1.1.1: icmp_seq=0 ttl=254 time=1.221 ms
64 bytes from 30.1.1.1: icmp_seq=1 ttl=254 time=0.865 ms
64 bytes from 30.1.1.1: icmp_seq=2 ttl=254 time=0.835 ms
64 bytes from 30.1.1.1: icmp_seq=3 ttl=254 time=0.821 ms
64 bytes from 30.1.1.1: icmp_seq=4 ttl=254 time=0.833 ms
^C
--- 30.1.1.1 ping statistics ---
5 packets transmitted, 5 packets received, 0.00% packet loss
round-trip min/avg/max = 0.821/0.915/1.221 ms
```

4. Setting up vPC domain and vPC Peer Keepalive.

```
DC1-N7K-1# configure terminal
Enter configuration commands, one per line. End with CNTL/Z.
DC1-N7K-1(config)# vpc domain 1
DC1-N7K-1(config-vpc-domain)# peer-keepalive destination 30.1.1.2 source 30.1.1.1 vrf keepalive
DC1-N7K-1(config-vpc-domain)# end
DC1-N7K-1# █
```

```
DC1-N7K-2(config)# vpc domain 1
DC1-N7K-2(config-vpc-domain)# peer-keepalive destination 30.1.1.1 source 30.1.1.2 vrf keepalive
DC1-N7K-2(config-vpc-domain)# end
DC1-N7K-2# █
```

In above, we had to define the destination and source IP Addresses with vrf “keepalive” which we created in Step 2.

5. Verification of vPC Peer Keepalive Link i.e. the Layer 3 Link.

```
DC1-N7K-1# show vpc peer-keepalive
```

```
vPC keep-alive status                : peer is alive
--Peer is alive for                  : (43) seconds, (874) msec
--Send status                        : Success
--Last send at                      : 2019.07.17 20:40:31 396 ms
--Sent on interface                  : Eth3/1
--Receive status                    : Success
--Last receive at                   : 2019.07.17 20:40:31 487 ms
--Received on interface              : Eth3/1
--Last update from peer             : (0) seconds, (830) msec
```

```
vPC Keep-alive parameters
--Destination                        : 30.1.1.2
--Keepalive interval                 : 1000 msec
--Keepalive timeout                  : 5 seconds
--Keepalive hold timeout             : 3 seconds
--Keepalive vrf                     : keepalive
--Keepalive udp port                 : 3200
--Keepalive tos                      : 192
```

```
DC1-N7K-1# █
```

```
DC1-N7K-2# show vpc peer-keepalive
```

```
vPC keep-alive status                : peer is alive
--Peer is alive for                  : (49) seconds, (570) msec
--Send status                         : Success
--Last send at                       : 2019.07.17 20:40:37 491 ms
--Sent on interface                  : Eth3/9
--Receive status                     : Success
--Last receive at                    : 2019.07.17 20:40:37 407 ms
--Received on interface              : Eth3/9
--Last update from peer              : (0) seconds, (490) msec
```

```
vPC Keep-alive parameters
--Destination                        : 30.1.1.1
--Keepalive interval                 : 1000 msec
--Keepalive timeout                  : 5 seconds
--Keepalive hold timeout             : 3 seconds
--Keepalive vrf                      : keepalive
--Keepalive udp port                 : 3200
--Keepalive tos                      : 192
```

```
DC1-N7K-2# █
```

6. Configure vPC Peer-Link between Peers . Note it must be 10 G link.

Switch 7K-1

```
DC1-N7K-1(config)# feature lacp
DC1-N7K-1(config)# interface ethernet 3/2
DC1-N7K-1(config-if)# no shutdown
DC1-N7K-1(config-if)# channel-group 1 mode active
DC1-N7K-1(config-if)# exit
DC1-N7K-1(config)# interface port-channel 1
DC1-N7K-1(config-if)# switchport mode trunk
DC1-N7K-1(config-if)# switchport trunk allowed vlan all
DC1-N7K-1(config-if)# no shutdown
DC1-N7K-1(config-if)# vpc peer-link
```

Switch 7K-2

```
DC1-N7K-2(config)# feature lacp
DC1-N7K-2(config)# interface ethernet 3/10
DC1-N7K-2(config-if)# no shutdown
DC1-N7K-2(config-if)# channel-group 1 mode active
DC1-N7K-2(config-if)# exit
DC1-N7K-2(config)# interface port-channel 1
DC1-N7K-2(config-if)# switchport
DC1-N7K-2(config-if)# switchport mode trunk
DC1-N7K-2(config-if)# switchport trunk allowed vlan all
DC1-N7K-2(config-if)# no shutdown
DC1-N7K-2(config-if)# vpc peer-link
```

Note : “**vpc peer-link**” command works only under Port-Channel. You can’t configure it on physical interface

7. Moving Member Ports in to vPC on Peer Switches and Configure Port-Channel on Nexus 5K.

```
DC1-N7K-1# configure terminal
Enter configuration commands, one per line. End with CNTL/Z.
DC1-N7K-1(config)# interface ethernet 3/4
DC1-N7K-1(config-if)# no shutdown
DC1-N7K-1(config-if)# channel-group 2 mode active
DC1-N7K-1(config-if)# exit
DC1-N7K-1(config)# interface port-channel 2
DC1-N7K-1(config-if)# no shutdown
DC1-N7K-1(config-if)# vpc 1
DC1-N7K-1(config-if)# end
DC1-N7K-1# █
```

```
DC1-N7K-2# configure terminal
Enter configuration commands, one per line. End with CNTL/Z.
DC1-N7K-2(config)# interface ethernet 3/12
DC1-N7K-2(config-if)# no shutdown
DC1-N7K-2(config-if)# channel-group 2 mode active
DC1-N7K-2(config-if)# exit
DC1-N7K-2(config)# interface port-channel 2
DC1-N7K-2(config-if)# no shutdown
DC1-N7K-2(config-if)# vpc 1
DC1-N7K-2(config-if)# end
DC1-N7K-2# █
```

```

N5K-1# configure terminal
Enter configuration commands, one per line. End with CNTL/Z.
N5K-1(config)# feature lacp
N5K-1(config)# interface ethernet 1/4 , ethernet 1/12
N5K-1(config-if-range)# no shutdown
N5K-1(config-if-range)# channel-group 2 mode active
N5K-1(config-if-range)# exit
N5K-1(config)# interface port-channel 2
N5K-1(config-if)# no shutdown
N5K-1(config-if)# end
N5K-1# █

```

8. Verify the vPC operation on all three Nexus Switches.

```
DC1-N7K-1# show vpc brief
```

Legend:

(*) - local vPC is down, forwarding via vPC peer-link

```

vPC domain id                : 1
Peer status                   : peer adjacency formed ok
vPC keep-alive status        : peer is alive
Configuration consistency status : success
Per-vlan consistency status   : success
Type-2 consistency status    : success
vPC role                      : primary
Number of vPCs configured    : 1
Peer Gateway                  : Disabled
Dual-active excluded VLANs and BDs : -
Graceful Consistency Check    : Enabled
Auto-recovery status         : Enabled, timer is off.(timeout = 240s)
Delay-restore status         : Timer is off.(timeout = 30s)
Delay-restore SVI status     : Timer is off.(timeout = 10s)
Operational Layer3 Peer-router : Disabled
Self-isolation                : Disabled

```

vPC Peer-link status

id	Port	Status	Active vlans	Active BDs
1	Po1	up	1,10,20,30,90	-

vPC status

id	Port	Status	Consistency	Active VLANs	Active BDs
1	Po2	up	success	-	-

```
DC1-N7K-1# █
```

```
DC1-N7K-2# show vpc brief
```

```
Legend:
```

```
(*) - local vPC is down, forwarding via vPC peer-link
```

```
vPC domain id           : 1
Peer status              : peer adjacency formed ok
vPC keep-alive status    : peer is alive
Configuration consistency status : success
Per-vlan consistency status : success
Type-2 consistency status : success
vPC role                 : secondary
Number of vPCs configured : 1
Peer Gateway             : Disabled
Dual-active excluded VLANs and BDs : -
Graceful Consistency Check : Enabled
Auto-recovery status     : Enabled, timer is off.(timeout = 240s)
Delay-restore status     : Timer is off.(timeout = 30s)
Delay-restore SVI status : Timer is off.(timeout = 10s)
Operational Layer3 Peer-router : Disabled
Self-isolation           : Disabled
```

```
vPC Peer-link status
```

```
-----
id  Port  Status Active vlans           Active BDs
--  --
1   Po1   up     1,10,20,30,90         -
```

```
vPC status
```

```
-----
id  Port  Status Consistency Active VLANs  Active BDs
--  --
1   Po2   up     success     -            -
```

```
DC1-N7K-2# █
```

Till now, you can see that vPC peer-link is up which is layer 2, vPC keepalive link is up which is a layer 3 link, vPC status is also reflecting as up which means our configuration is correct.

9. Check the Status of Port-Channel on Nexus 5K-1 which is a downstream switch.

```
N5K-1# show port-channel summ
```

```
Flags:  D - Down          P - Up in port-channel (members)
        I - Individual    H - Hot-standby (LACP only)
        s - Suspended     r - Module-removed
        S - Switched     R - Routed
        U - Up (port-channel)
        M - Not in use. Min-links not met
```

```
-----
Group Port-          Type      Protocol  Member Ports
  Channel
-----
2     Po2(SU)        Eth       LACP      Eth1/4(P)  Eth1/12(P)
N5K-1#
```

10. Check Port-Channel status on vPC peer Switches i.e. Nexus 7K-1 and 2.

```
DC1-N7K-1# show port-channel summary
```

```
Flags:  D - Down          P - Up in port-channel (members)
        I - Individual    H - Hot-standby (LACP only)
        s - Suspended     r - Module-removed
        b - BFD Session Wait
        S - Switched     R - Routed
        U - Up (port-channel)
        M - Not in use. Min-links not met
```

```
-----
Group Port-          Type      Protocol  Member Ports
  Channel
-----
1     Po1(SU)        Eth       LACP      Eth3/2(P)
2     Po2(RU)        Eth       LACP      Eth3/4(P)
DC1-N7K-1#
```

```
DC1-N7K-2# show port-channel summary
```

```
Flags: D - Down          P - Up in port-channel (members)
       I - Individual    H - Hot-standby (LACP only)
       s - Suspended     r - Module-removed
       b - BFD Session Wait
       S - Switched     R - Routed
       U - Up (port-channel)
       M - Not in use. Min-links not met
```

```
-----
Group Port-          Type      Protocol  Member Ports
  Channel
-----
1      Po1(SU)        Eth       LACP      Eth3/10(P)
2      Po2(RU)        Eth       LACP      Eth3/12(P)
```

```
DC1-N7K-2# █
```

Above outputs of port-channels show that port status is P which means UP and working.

11. Verify the consistency parameters on vPC Peer Switches.

```
DC1-N7K-1# show vpc consistency-parameters vpc 1
```

Legend:

Type 1 : vPC will be suspended in case of mismatch

Name	Type	Local Value	Peer Value
Interface type	1	port-channel	port-channel
LACP Mode	1	on	on
STP Port Guard	1	Default	Default
STP Port Type	1	Default	Default
Speed	1	1000 Mb/s	1000 Mb/s
Duplex	1	full	full
MTU	1	9192	9192
Vlan xlt mapping	1	Enabled	Enabled
Port Mode	1	--	--
STP MST Simulate PVST	1	Default	Default
Native Vlan	1	1	1
Admin port mode	1	--	--
lag-id	1	[(7f9b, 0-23-4-ee-be-1, 8001, 0, 0), (8000, 0-de-fb-73-4-bc, 1, 0, 0)]	[(7f9b, 0-23-4-ee-be-1, 8001, 0, 0), (8000, 0-de-fb-73-4-bc, 1, 0, 0)]
mode	1	active	active
vPC card type	1	F3	F3
Allowed VLANs	-	4095	4095
Local error VLANs	-	-	-

```
DC1-N7K-1# █
```

```
DC1-N7K-2# show vpc consistency-parameters vpc 1
```

Legend:

Type 1 : vPC will be suspended in case of mismatch

Name	Type	Local Value	Peer Value
Interface type	1	port-channel	port-channel
LACP Mode	1	on	on
STP Port Guard	1	Default	Default
STP Port Type	1	Default	Default
Speed	1	1000 Mb/s	1000 Mb/s
Duplex	1	full	full
MTU	1	9192	9192
Vlan xlt mapping	1	Enabled	Enabled
Port Mode	1	--	--
STP MST Simulate PVST	1	Default	Default
Native Vlan	1	1	1
Admin port mode	1	--	--
lag-id	1	[(7f9b, 0-23-4-ee-be-1, 8001, 0, 0), (8000, 0-de-fb-73-4-bc, 1, 0, 0)]	[(7f9b, 0-23-4-ee-be-1, 8001, 0, 0), (8000, 0-de-fb-73-4-bc, 1, 0, 0)]
mode	1	active	active
vPC card type	1	F3	F3
Allowed VLANs	-	4095	4095
Local error VLANs	-	-	-

```
DC1-N7K-2# █
```

This above command is very helpful in order to match the configuration of your switch with vPC peer switch. If there is inconsistency, you will not see vPC status as up.

12. Verify the vPC role on Peer Switches.

```
DC1-N7K-1# show vpc role
```

```
vPC Role status
```

```
-----  
vPC role : primary  
vPC system-mac : 00:23:04:ee:be:01  
vPC system-priority : 32667  
vPC local system-mac : 70:d3:79:63:6a:c2  
vPC local role-priority : 32667  
vPC peer system-mac : 70:d3:79:63:6a:c3  
vPC peer role-priority : 32667  
DC1-N7K-1# █
```

```
DC1-N7K-2# show vpc role
```

```
vPC Role status
```

```
-----  
vPC role : secondary  
vPC system-mac : 00:23:04:ee:be:01  
vPC system-priority : 32667  
vPC local system-mac : 70:d3:79:63:6a:c3  
vPC local role-priority : 32667  
vPC peer system-mac : 70:d3:79:63:6a:c2  
vPC peer role-priority : 32667  
DC1-N7K-2# █
```

Though, you will see vPC Primary and Secondary roles, but vPC always work in Active-Active. These roles come in picture when peer-link is down so that Switch with Secondary role can suspend member ports to avoid vPC loops.

Lab 6 : Configuring multiple vPCs (Virtual Port Channel)

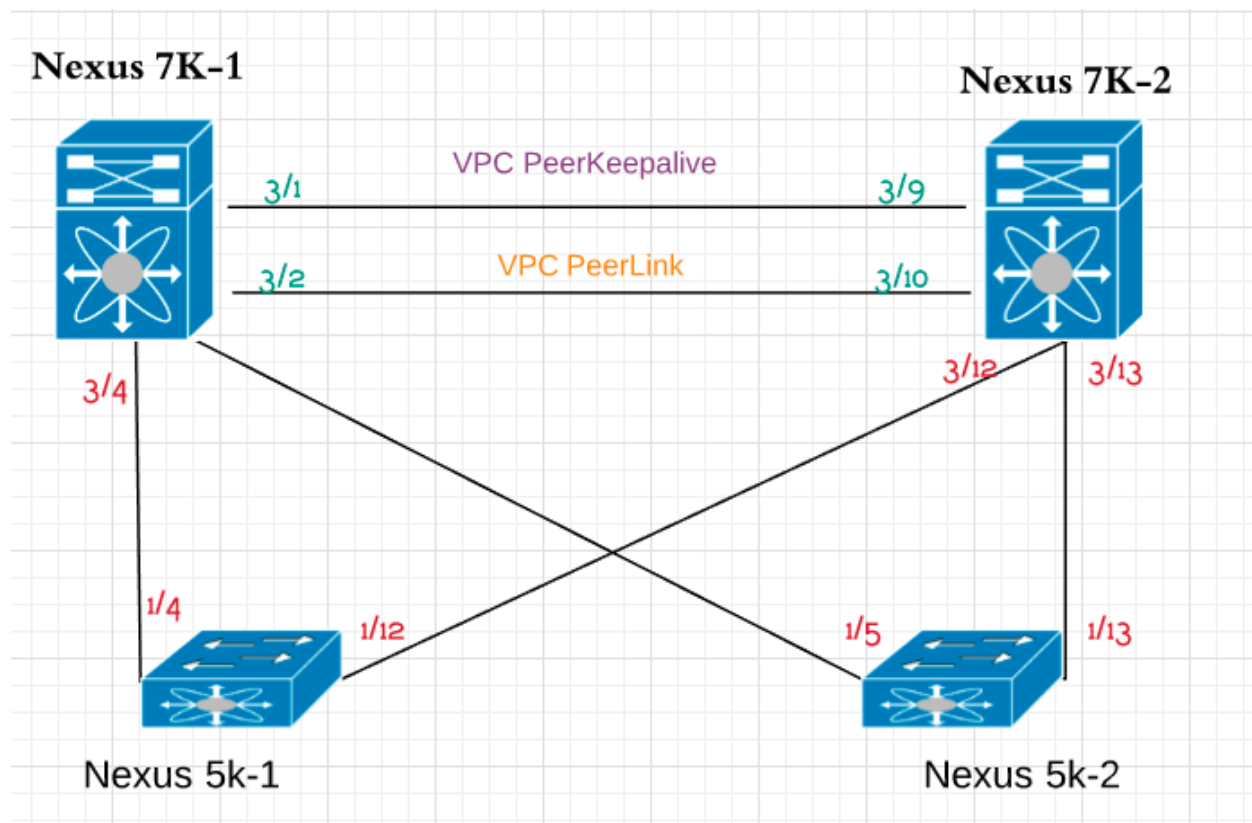

It is very similar to what we did in Lab 5. It is just that we have one additional switch i.e. 5K-2 in this

topology. We need not do any change w.r.t configuration of vpc domain, vpc peer keepalive, vpc peer link. We simply need to configure the downstream ports of vpc peer switches connected to new switch 5K-2 and move these in to **vpc 2**. Along with that we need to configure 5K-2 ports.

Here I will show you the additional configuration required for setting 5K-2. Rest of the configuration is totally same as Lab 5.

1. Configuration of member ports of peer switches which are connected to switch Nexus 5K-2.

```
DC1-N7K-1# configure terminal
Enter configuration commands, one per line.  End with CNTL/Z.
DC1-N7K-1(config)# interface ethernet 3/5
DC1-N7K-1(config-if)# switchport
DC1-N7K-1(config-if)# no shutdown
DC1-N7K-1(config-if)# channel-group 3 mode active
DC1-N7K-1(config-if)# exit
DC1-N7K-1(config)# interface port-channel 3
DC1-N7K-1(config-if)# no shutdown
DC1-N7K-1(config-if)# vpc 2
DC1-N7K-1(config-if)# end
DC1-N7K-1# █
```

```
DC1-N7K-2# configure terminal
Enter configuration commands, one per line.  End with CNTL/Z.
DC1-N7K-2(config)# interface ethernet 3/13
DC1-N7K-2(config-if)# switchport
DC1-N7K-2(config-if)# no shutdown
DC1-N7K-2(config-if)# channel-group 3 mode active
DC1-N7K-2(config-if)# exit
DC1-N7K-2(config)# interface port-channel 3
DC1-N7K-2(config-if)# no shutdown
DC1-N7K-2(config-if)# vpc 2
DC1-N7K-2(config-if)# end
DC1-N7K-2# █
```

2. Configuration of ports on 5K-2 which are connecting to Peer Switches 7K-1 and 7K-2

```

N5K-2# configure terminal
Enter configuration commands, one per line. End with CNTL/Z.
N5K-2(config)# feature lacp
N5K-2(config)# interface ethernet 1/5, ethernet 1/13
N5K-2(config-if-range)# no shutdown
N5K-2(config-if-range)# switchport
N5K-2(config-if-range)# channel-group 3 mode active
N5K-2(config-if-range)# exit
N5K-2(config)# interface port-channel 3
N5K-2(config-if)# no shutdown
N5K-2(config-if)# end

```

3. Verifying port-channels on Nexus switches 7K-1, 7K-2, 5K-2.

```

DC1-N7K-1# show port-channel summary
Flags:  D - Down          P - Up in port-channel (members)
        I - Individual   H - Hot-standby (LACP only)
        s - Suspended    r - Module-removed
        b - BFD Session Wait
        S - Switched     R - Routed
        U - Up (port-channel)
        M - Not in use. Min-links not met
-----
Group Port-      Type   Protocol  Member Ports
      Channel
-----
1     Po1(SU)     Eth    LACP      Eth3/2(P)
2     Po2(RU)     Eth    LACP      Eth3/4(P)
3     Po3(SU)     Eth    LACP      Eth3/5(P)
DC1-N7K-1# █

```

```
DC1-N7K-2# show port-channel summary
```

```
Flags: D - Down          P - Up in port-channel (members)
       I - Individual    H - Hot-standby (LACP only)
       s - Suspended     r - Module-removed
       b - BFD Session Wait
       S - Switched      R - Routed
       U - Up (port-channel)
       M - Not in use. Min-links not met
```

```
-----
Group Port-      Type      Protocol  Member Ports
  Channel
-----
1     Po1(SU)    Eth       LACP      Eth3/10(P)
2     Po2(RU)    Eth       LACP      Eth3/12(P)
3     Po3(SU)    Eth       LACP      Eth3/13(P)
```

```
DC1-N7K-2# █
```

```
N5K-2# show port-channel summary
```

```
Flags: D - Down          P - Up in port-channel (members)
       I - Individual    H - Hot-standby (LACP only)
       s - Suspended     r - Module-removed
       S - Switched      R - Routed
       U - Up (port-channel)
       M - Not in use. Min-links not met
```

```
-----
Group Port-      Type      Protocol  Member Ports
  Channel
-----
3     Po3(SU)    Eth       LACP      Eth1/5(P)   Eth1/13(P)
```

4. Verifying vPC 2 i.e. the additional vPC. Here we have two vPCs 1 & 2

```
DC1-N7K-1# show vpc brief
```

```
Legend:
```

```
(*) - local vPC is down, forwarding via vPC peer-link
```

```
vPC domain id           : 1
Peer status             : peer adjacency formed ok
vPC keep-alive status   : peer is alive
Configuration consistency status : success
Per-vlan consistency status : success
Type-2 consistency status : success
vPC role                : primary
Number of vPCs configured : 2
Peer Gateway            : Disabled
Dual-active excluded VLANs and BDs : -
Graceful Consistency Check : Enabled
Auto-recovery status    : Enabled, timer is off.(timeout = 240s)
Delay-restore status    : Timer is off.(timeout = 30s)
Delay-restore SVI status : Timer is off.(timeout = 10s)
Operational Layer3 Peer-router : Disabled
Self-isolation          : Disabled
```

```
vPC Peer-link status
```

```
-----
id  Port  Status Active vlans           Active BDs
--  ---  -----
1   Po1   up    1,10,20,30,90          -
```

```
vPC status
```

```
-----
id  Port  Status Consistency Active VLANs  Active BDs
-----
1   Po2   up    success    -            -
2   Po3   up    success    1            -
```

```
DC1-N7K-1# █
```

```
DC1-N7K-2# show vpc brief
```

```
Legend:
```

```
(*) - local vPC is down, forwarding via vPC peer-link
```

```
vPC domain id           : 1
Peer status              : peer adjacency formed ok
vPC keep-alive status    : peer is alive
Configuration consistency status : success
Per-vlan consistency status : success
Type-2 consistency status : success
vPC role                 : secondary
Number of vPCs configured : 2
Peer Gateway             : Disabled
Dual-active excluded VLANs and BDs : -
Graceful Consistency Check : Enabled
Auto-recovery status     : Enabled, timer is off.(timeout = 240s)
Delay-restore status     : Timer is off.(timeout = 30s)
Delay-restore SVI status : Timer is off.(timeout = 10s)
Operational Layer3 Peer-router : Disabled
Self-isolation          : Disabled
```

```
vPC Peer-link status
```

```
-----
id  Port  Status Active vlans           Active BDs
--  --
1   Po1   up    1,10,20,30,90         -
```

```
vPC status
```

```
-----
id  Port  Status Consistency Active VLANs  Active BDs
--  --
1   Po2   up    success    -            -
2   Po3   up    success    1            -
```

```
DC1-N7K-2# █
```

Above output of Switches N7L-1 and 2 show two vPCs. It means that now, we have multiple vPCs configured between Peer Switches.

Lab 7 : Case Study in vPCs (Virtual Port Channel)

1. What happens when vPC peer-link goes down but vPC keepalive is up?

```

DC1-N7K-1# configure terminal
Enter configuration commands, one per line.  End with CNTL/Z.
DC1-N7K-1(config)# interface ethernet 3/2
DC1-N7K-1(config-if)# shutdown
DC1-N7K-1(config-if)# end
DC1-N7K-1# █

```

In above snapshot, we shutdown the Peer-Link Interface at N7K-1 switch.

```
DC1-N7K-1# show vpc brief
```

Legend:

(*) - local vPC is down, forwarding via vPC peer-link

```

vPC domain id           : 1
Peer status              : peer link is down
vPC keep-alive status   : peer is alive
Configuration consistency status : success
Per-vlan consistency status : success
Type-2 consistency status : success
vPC role                 : primary
Number of vPCs configured : 2
Peer Gateway             : Disabled
Dual-active excluded VLANs and BDs : -
Graceful Consistency Check : Enabled
Auto-recovery status    : Enabled, timer is off.(timeout = 240s)
Delay-restore status    : Timer is off.(timeout = 30s)
Delay-restore SVI status : Timer is off.(timeout = 10s)
Operational Layer3 Peer-router : Disabled
Self-isolation          : Disabled

```

vPC Peer-link status

id	Port	Status	Active vlans	Active BDs
1	Po1	down	-	-

vPC status

id	Port	Status	Consistency	Active VLANs	Active BDs
1	Po2	up	success	-	-
2	Po3	up	success	1	-

```
DC1-N7K-1# █
```

Above you can see that vPC peer-link status is showing as down while vPC status is up and consistency is success.

```
DC1-N7K-2# show vpc brief
```

```
Legend:
```

```
(*) - local vPC is down, forwarding via vPC peer-link
```

```
vPC domain id          : 1
Peer status            : peer link is down
vPC keep-alive status  : peer is alive
Configuration consistency status : success
Per-vlan consistency status : success
Type-2 consistency status : success
vPC role               : secondary
Number of vPCs configured : 2
Peer Gateway           : Disabled
Dual-active excluded VLANs and BDs : -
Graceful Consistency Check : Enabled
Auto-recovery status   : Enabled, timer is off.(timeout = 240s)
Delay-restore status   : Timer is off.(timeout = 30s)
Delay-restore SVI status : Timer is off.(timeout = 10s)
Operational Layer3 Peer-router : Disabled
Self-isolation         : Disabled
```

```
vPC Peer-link status
```

```
-----
id  Port   Status Active vlans      Active BDs
--  ----  -
1   Po1    down  -                 -
```

```
vPC status
```

```
-----
id  Port      Status Consistency Active VLANs  Active BDs
--  ----  -
1   Po2      down  success     -             -
2   Po3      down  success     -             -
```

```
DC1-N7K-2# show interface ethernet 3/12 , ethernet 3/13 | i suspend
```

```
Ethernet3/12 is down (suspended by vpc)
```

```
Ethernet3/13 is down (suspended by vpc)
```

```
DC1-N7K-2# █
```

In above output, you can see that member ports are suspended on N7K-2 as this is secondary switch. This happened to make sure that there is no impact to vPC traffic and operation. In this scenario, we kept the peer-keepalive link up while peer-link was shutdown.

2. What happens when peer keepalive is down, but peer link is up?

```

DC1-N7K-1(config)# interface ethernet 3/2
DC1-N7K-1(config-if)# no shutdown
DC1-N7K-1(config-if)# exit
DC1-N7K-1(config)# interface ethernet 3/1
DC1-N7K-1(config-if)# shutdown
DC1-N7K-1(config-if)# end
DC1-N7K-1# █

```

Here we shutdown the Interface Eth3/1 since it is keepalive link while Eth3/2 is peer-link which is up.

```

DC1-N7K-1# show vpc brief
Legend:
(*) - local vPC is down, forwarding via vPC peer-link

vPC domain id          : 1
Peer status            : peer adjacency formed ok
vPC keep-alive status  : peer is not reachable through peer-keepalive
Configuration consistency status : success
Per-vlan consistency status : success
Type-2 consistency status : success
vPC role               : primary
Number of vPCs configured : 2
Peer Gateway          : Disabled
Dual-active excluded VLANs and BDs : -
Graceful Consistency Check : Enabled
Auto-recovery status  : Enabled, timer is off.(timeout = 240s)
Delay-restore status  : Timer is off.(timeout = 30s)
Delay-restore SVI status : Timer is off.(timeout = 10s)
Operational Layer3 Peer-router : Disabled
Self-isolation        : Disabled

vPC Peer-link status
-----
id  Port  Status Active vlans          Active BDs
--  ---  -----
1   Po1   up    1,10,20,30,90          -

vPC status
-----
id  Port  Status Consistency Active VLANs  Active BDs
--  ---  -----
1   Po2   up    success     -            -
2   Po3   up    success     1            -
DC1-N7K-1# █

```

Above you can see that vPC Peer-link is up , Peer-Keepalive is shutdown and there is no impact to vPC operations because vPC status is up and successful.

```
DC1-N7K-2# show vpc brief
```

```
Legend:
```

```
(*) - local vPC is down, forwarding via vPC peer-link
```

```
vPC domain id           : 1
Peer status             : peer adjacency formed ok
vPC keep-alive status   : peer is not reachable through peer-keepalive
Configuration consistency status : success
Per-vlan consistency status : success
Type-2 consistency status : success
vPC role                : secondary
Number of vPCs configured : 2
Peer Gateway            : Disabled
Dual-active excluded VLANs and BDs : -
Graceful Consistency Check : Enabled
Auto-recovery status    : Enabled, timer is off.(timeout = 240s)
Delay-restore status    : Timer is off.(timeout = 30s)
Delay-restore SVI status : Timer is off.(timeout = 10s)
Operational Layer3 Peer-router : Disabled
Self-isolation          : Disabled
```

```
vPC Peer-link status
```

```
-----
id  Port  Status Active vlans           Active BDs
--  ---  -
1   Po1   up    1,10,20,30,90         -
-----
```

```
vPC status
```

```
-----
id  Port  Status Consistency Active VLANs  Active BDs
--  ---  -
1   Po2   up    success    -            -
2   Po3   up    success    1            -
-----
```

```
DC1-N7K-2# █
```

You need to wait for 30 seconds to see the correct vPC status after enabling the peer-link because it was intentionally shutdown by us in previous case study.

So, there is no impact to operation at all when keepalive is down while peer-link is up because vPC status is showing as up.

Lab 8 : FabricPath Configuration

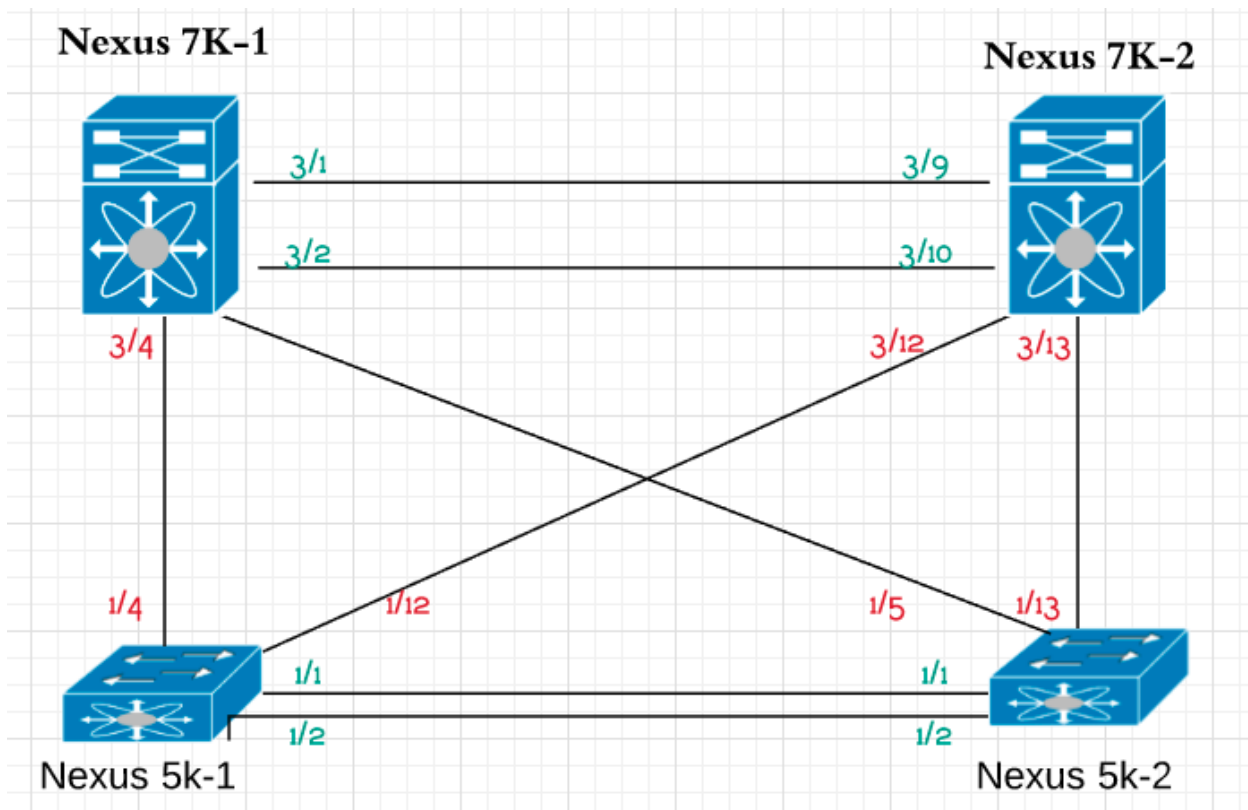

1. Install and activate the feature-set of fabricpath.

Nexus 5K-1

```
DC1-N5K-1# configure terminal
Enter configuration commands, one per line. End with CNTL/Z.
DC1-N5K-1(config)# feature-set fabricpath
^
% Invalid command at '^' marker.
DC1-N5K-1(config)# install feature-set fabricpath
DC1-N5K-1(config)# feature-set fabricpath
DC1-N5K-1(config)# end
DC1-N5K-1# show feature-set | include fabricpath
fabricpath                2                enabled
DC1-N5K-1#
```

Nexus-5k-2

```
DC1-N5K-2# configure terminal
Enter configuration commands, one per line. End with CNTL/Z.
DC1-N5K-2(config)# install feature-set fabricpath
DC1-N5K-2(config)# feature-set fabricpath
DC1-N5K-2(config)# end
DC1-N5K-2# █
```

Nexus 7K Default VDC– Here you need to make sure that Default VDC has this license installed. Only then you will be able to initialize feature-set of fabricpath on other VDCs.

```
DC1-N7K# configure terminal
Enter configuration commands, one per line. End with CNTL/Z.
DC1-N7K(config)# install feature-set fabricpath
DC1-N7K(config)# end
DC1-N7K# show feature-set | include fabricpath
fabricpath                2                installed
DC1-N7K# █
```

Nexus 7K-1

```
DC1-N7K-1# configure terminal
Enter configuration commands, one per line. End with CNTL/Z.
DC1-N7K-1(config)# feature-set fabricpath
DC1-N7K-1(config)# end
DC1-N7K-1# show feature-set | include fabricpath
fabricpath                2                enabled
DC1-N7K-1# █
```

Nexus 7K-2

```
DC1-N7K-2# configure terminal
Enter configuration commands, one per line. End with CNTL/Z.
DC1-N7K-2(config)# feature-set fabricpath
DC1-N7K-2(config)# end
DC1-N7K-2# show feature-set | include fabricpath
fabricpath                2                enabled
DC1-N7K-2# █
```

2. Enable fabricpath on Interfaces of all four nexus switches. Note that Only F Series Module Ports can be used for enabling fabricpath.

Nexus 7K-1

```
DC1-N7K-1# configure terminal
Enter configuration commands, one per line. End with CNTL/Z.
DC1-N7K-1(config)# interface ethernet 3/1-2, ethernet3/4-5
DC1-N7K-1(config-if-range)# switchport
DC1-N7K-1(config-if-range)# switchport mode fabricpath
DC1-N7K-1(config-if-range)# end
```

Nexus 7K-2

```
DC1-N7K-2# configure terminal
Enter configuration commands, one per line. End with CNTL/Z.
DC1-N7K-2(config)# interface ethernet3/9-10, ethernet3/12-13
DC1-N7K-2(config-if-range)# switchport
DC1-N7K-2(config-if-range)# switchport mode fabricpath
DC1-N7K-2(config-if-range)# end
```

Nexus 5K-1

```
DC1-N5K-1# configure terminal
Enter configuration commands, one per line. End with CNTL/Z.
DC1-N5K-1(config)# interface ethernet 1/1-2, ethernet 1/4, ethernet 1/12
DC1-N5K-1(config-if-range)# switchport
DC1-N5K-1(config-if-range)# switchport mode fabricpath
DC1-N5K-1(config-if-range)# end
DC1-N5K-1# █
```

Nexus 5K-2

```
DC1-N5K-2(config)# interface ethernet 1/1-2, ethernet 1/5, ethernet 1/13
DC1-N5K-2(config-if-range)# switchport
DC1-N5K-2(config-if-range)# switchport mode fabricpath
DC1-N5K-2(config-if-range)# end
DC1-N5K-2# █
```

3. Verify the status of Interfaces which are now in “fabricpath” mode.

```
DC1-N7K-1# show interface status | include 3/1|3/2|3/4|3/5
Eth3/1      --      connected f-path    full    a-1000  1000base-T
Eth3/2      --      connected f-path    full    a-1000  1000base-T
Eth3/4      --      connected f-path    full    a-1000  1000base-T
Eth3/5      --      connected f-path    full    a-1000  1000base-T
DC1-N7K-1# █
```

```
DC1-N7K-2# show interface status | include 3/9|3/10|3/12|3/13
Eth3/9      --      connected f-path    full    a-1000  1000base-T
Eth3/10     --      connected f-path    full    a-1000  1000base-T
Eth3/12     --      connected f-path    full    a-1000  1000base-T
Eth3/13     --      connected f-path    full    a-1000  1000base-T
DC1-N7K-2# █
```

```

DC1-N5K-1# show interface status | i f-path
Eth1/1      --          connected f-path    full    10G    10Gbase-SR
Eth1/2      --          connected f-path    full    10G    10Gbase-SR
Eth1/4      --          connected f-path    full    1000   SFP-1000BAS
Eth1/12     --          connected f-path    full    1000   SFP-1000BAS
DC1-N5K-1# █

```

```

DC1-N5K-2# show int status | i f-path
Eth1/1      --          connected f-path    full    10G    10Gbase-SR
Eth1/2      --          connected f-path    full    10G    10Gbase-SR
Eth1/5      --          connected f-path    full    1000   SFP-1000BAS
Eth1/13     --          connected f-path    full    1000   SFP-1000BAS
DC1-N5K-2# █

```

You will note that the status of ports has changed to “f-path”.

4. Configure a vlan 222 and move it in fabricpath.

Nexus 5K-1

```

DC1-N5K-1# configure terminal
Enter configuration commands, one per line. End with CNTL/Z.
DC1-N5K-1(config)# vlan 222
DC1-N5K-1(config-vlan)# name ashish-fpath
DC1-N5K-1(config-vlan)# mode fabricpath
DC1-N5K-1(config-vlan)# end
DC1-N5K-1# █

```

Nexus 5K-2

```

DC1-N5K-2# configure terminal
Enter configuration commands, one per line. End with CNTL/Z.
DC1-N5K-2(config)# vlan 222
DC1-N5K-2(config-vlan)# name ashish-fpath
DC1-N5K-2(config-vlan)# mode fabricpath
DC1-N5K-2(config-vlan)# end
DC1-N5K-2# █

```

Nexus 7K-1

```

DC1-N7K-1# configure terminal
Enter configuration commands, one per line. End with CNTL/Z.
DC1-N7K-1(config)# vlan 222
DC1-N7K-1(config-vlan)# name ashish-fpath
DC1-N7K-1(config-vlan)# mode fabricpath
DC1-N7K-1(config-vlan)# end
DC1-N7K-1# █

```

Nexus 7K-2

```
DC1-N7K-2# configure terminal
Enter configuration commands, one per line. End with CNTL/Z.
DC1-N7K-2(config)# vlan 222
DC1-N7K-2(config-vlan)# name ashish-fpath
DC1-N7K-2(config-vlan)# mode fabricpath
DC1-N7K-2(config-vlan)# end
DC1-N7K-2# █
```

5. Verify the status of Spanning-Tree for Vlan 222 and mode of Vlan 222.

```
DC1-N7K-1# show spanning-tree vlan 222
Spanning tree instance(s) for vlan does not exist.
DC1-N7K-1# show vlan id 222 | section Vlan-mode|enet
VLAN Type          Vlan-mode
222  enet           FABRICPATH
DC1-N7K-1# █
```

```
DC1-N7K-2# show spanning-tree vlan 222
Spanning tree instance(s) for vlan does not exist.
DC1-N7K-2# show vlan id 222 | section Vlan-mode|enet
VLAN Type          Vlan-mode
222  enet           FABRICPATH
DC1-N7K-2# █
```

```
DC1-N5K-1# show spanning-tree vlan 222
Spanning tree instance(s) for vlan does not exist.
DC1-N5K-1# show vlan id 222 | section Vlan-mode|enet
VLAN Type  Vlan-mode
222  enet  FABRICPATH
DC1-N5K-1# █
```

```
DC1-N5K-2# show spanning-tree vlan 222
Spanning tree instance(s) for vlan does not exist.
DC1-N5K-2# show vlan id 222 | section Vlan-mode|enet
VLAN Type  Vlan-mode
222  enet  FABRICPATH
DC1-N5K-2# █
```

You will see spanning-tree status for vlan 222 on switch which will have both fabricpath domain and classical ethernet domain. You will see more when you connect Hosts on Switches.

6. Verify the status of ISIS in Fabricpath.

ISIS is automatically enabled when we configure fabricpath on interfaces.

```
DC1-N7K-1# show fabricpath isis interface brief
```

```
Fabricpath IS-IS domain: default
```

Interface	Type	Idx	State	Circuit	MTU	Metric	Priority	Adjs/AdjsUp
Ethernet3/1	P2P	1	Up/Ready	0x01/L1	1500	400	64	1/1
Ethernet3/2	P2P	2	Up/Ready	0x01/L1	1500	400	64	1/1
Ethernet3/4	P2P	3	Up/Ready	0x01/L1	1500	400	64	1/1
Ethernet3/5	P2P	4	Up/Ready	0x01/L1	1500	400	64	1/1

```
DC1-N7K-1# show fabricpath isis adjacency
```

```
Fabricpath IS-IS domain: default Fabricpath IS-IS adjacency database:
```

System ID	SNPA	Level	State	Hold Time	Interface
DC1-N7K-2	N/A	1	UP	00:00:25	Ethernet3/1
DC1-N7K-2	N/A	1	UP	00:00:30	Ethernet3/2
DC1-N5K-1	N/A	1	UP	00:00:29	Ethernet3/4
DC1-N5K-2	N/A	1	UP	00:00:25	Ethernet3/5

```
DC1-N7K-2# show fabricpath isis interface brief
```

```
Fabricpath IS-IS domain: default
```

Interface	Type	Idx	State	Circuit	MTU	Metric	Priority	Adjs/AdjsUp
Ethernet3/9	P2P	1	Up/Ready	0x01/L1	1500	400	64	1/1
Ethernet3/10	P2P	2	Up/Ready	0x01/L1	1500	400	64	1/1
Ethernet3/12	P2P	3	Up/Ready	0x01/L1	1500	400	64	1/1
Ethernet3/13	P2P	4	Up/Ready	0x01/L1	1500	400	64	1/1

```
DC1-N7K-2# show fabricpath isis adjacency
```

```
Fabricpath IS-IS domain: default Fabricpath IS-IS adjacency database:
```

System ID	SNPA	Level	State	Hold Time	Interface
DC1-N7K-1	N/A	1	UP	00:00:29	Ethernet3/9
DC1-N7K-1	N/A	1	UP	00:00:29	Ethernet3/10
DC1-N5K-1	N/A	1	UP	00:00:28	Ethernet3/12
DC1-N5K-2	N/A	1	UP	00:00:30	Ethernet3/13

```
DC1-N5K-1# show fabricpath isis interface brief
```

```
Fabricpath IS-IS domain: default
```

Interface	Type	Idx	State	Circuit	MTU	Metric	Priority	Adjs/AdjsUp
Ethernet1/1	P2P	3	Up/Ready	0x01/L1	1500	40	64	1/1
Ethernet1/2	P2P	4	Up/Ready	0x01/L1	1500	40	64	1/1
Ethernet1/4	P2P	1	Up/Ready	0x01/L1	1500	400	64	1/1
Ethernet1/12	P2P	2	Up/Ready	0x01/L1	1500	400	64	1/1

```
DC1-N5K-1# show fabricpath isis adjacency
```

```
Fabricpath IS-IS domain: default Fabricpath IS-IS adjacency database:
```

System ID	SNPA	Level	State	Hold Time	Interface
DC1-N5K-2	N/A	1	UP	00:00:30	Ethernet1/1
DC1-N5K-2	N/A	1	UP	00:00:27	Ethernet1/2
DC1-N7K-1	N/A	1	UP	00:00:27	Ethernet1/4
DC1-N7K-2	N/A	1	UP	00:00:27	Ethernet1/12

```
DC1-N5K-2# show fabricpath isis interface brief
```

```
Fabricpath IS-IS domain: default
```

Interface	Type	Idx	State	Circuit	MTU	Metric	Priority	Adjs/AdjsUp
Ethernet1/1	P2P	2	Up/Ready	0x01/L1	1500	40	64	1/1
Ethernet1/2	P2P	3	Up/Ready	0x01/L1	1500	40	64	1/1
Ethernet1/5	P2P	4	Up/Ready	0x01/L1	1500	400	64	1/1
Ethernet1/13	P2P	1	Up/Ready	0x01/L1	1500	400	64	1/1

```
DC1-N5K-2# show fabricpath isis adjacency
```

```
Fabricpath IS-IS domain: default Fabricpath IS-IS adjacency database:
```

System ID	SNPA	Level	State	Hold Time	Interface
DC1-N5K-1	N/A	1	UP	00:00:30	Ethernet1/1
DC1-N5K-1	N/A	1	UP	00:00:25	Ethernet1/2
DC1-N7K-1	N/A	1	UP	00:00:31	Ethernet1/5
DC1-N7K-2	N/A	1	UP	00:00:27	Ethernet1/13

7. Check the status of fabricpath switch-id on each device.

```
DC1-N7K-1# show fabricpath switch-id
```

```
FABRICPATH SWITCH-ID TABLE
```

```
Legend: '*' - this system
```

```
'[E]' - local Emulated Switch-id
```

```
'[A]' - local Anycast Switch-id
```

```
Total Switch-ids: 4
```

SWITCH-ID	SYSTEM-ID	FLAGS	STATE	STATIC	EMULATED/ ANYCAST
* 1802	70d3.7963.6ac2	Primary	Confirmed	No	No
1868	00de.fb73.057c	Primary	Confirmed	No	No
3715	00de.fb73.04bc	Primary	Confirmed	No	No
4070	70d3.7963.6ac3	Primary	Confirmed	No	No

```
DC1-N7K-2# show fabricpath switch-id
```

```
FABRICPATH SWITCH-ID TABLE
```

```
Legend: '*' - this system
```

```
'[E]' - local Emulated Switch-id
```

```
'[A]' - local Anycast Switch-id
```

```
Total Switch-ids: 4
```

SWITCH-ID	SYSTEM-ID	FLAGS	STATE	STATIC	EMULATED/ ANYCAST
1802	70d3.7963.6ac2	Primary	Confirmed	No	No
1868	00de.fb73.057c	Primary	Confirmed	No	No
3715	00de.fb73.04bc	Primary	Confirmed	No	No
* 4070	70d3.7963.6ac3	Primary	Confirmed	No	No

```
DC1-N5K-1# show fabricpath switch-id
```

```
FABRICPATH SWITCH-ID TABLE
```

```
Legend: '*' - this system
```

```
'[E]' - local Emulated Switch-id
```

```
'[A]' - local Anycast Switch-id
```

```
Total Switch-ids: 4
```

```
=====
```

SWITCH-ID	SYSTEM-ID	FLAGS	STATE	STATIC	EMULATED/ ANYCAST
1802	70d3.7963.6ac2	Primary	Confirmed	No	No
1868	00de.fb73.057c	Primary	Confirmed	No	No
* 3715	00de.fb73.04bc	Primary	Confirmed	No	No
4070	70d3.7963.6ac3	Primary	Confirmed	No	No

```
-----
```

```
DC1-N5K-2# show fabricpath switch-id
```

```
FABRICPATH SWITCH-ID TABLE
```

```
Legend: '*' - this system
```

```
'[E]' - local Emulated Switch-id
```

```
'[A]' - local Anycast Switch-id
```

```
Total Switch-ids: 4
```

```
=====
```

SWITCH-ID	SYSTEM-ID	FLAGS	STATE	STATIC	EMULATED/ ANYCAST
1802	70d3.7963.6ac2	Primary	Confirmed	No	No
* 1868	00de.fb73.057c	Primary	Confirmed	No	No
3715	00de.fb73.04bc	Primary	Confirmed	No	No
4070	70d3.7963.6ac3	Primary	Confirmed	No	No

```
-----
```

8. Check the Fabricpath Routing Table.

```
DC1-N7K-1# show fabricpath route
FabricPath Unicast Route Table
'a/b/c' denotes ftag/switch-id/subswitch-id
'[x/y]' denotes [admin distance/metric]
ftag 0 is local ftag
subswitch-id 0 is default subswitch-id
```

FabricPath Unicast Route Table for Topology-Default

```
0/1802/0, number of next-hops: 0
    via ---- , [60/0], 0 day/s 01:14:11, local
0/1802/3, number of next-hops: 1
    via sup-eth1, [81/0], 0 day/s 01:14:11, fpoam
1/1868/0, number of next-hops: 1
    via Eth3/5, [115/400], 0 day/s 00:33:09, isis_fabricpath-default
1/3715/0, number of next-hops: 1
    via Eth3/4, [115/400], 0 day/s 00:33:51, isis_fabricpath-default
1/4070/0, number of next-hops: 2
    via Eth3/1, [115/400], 0 day/s 00:51:57, isis_fabricpath-default
    via Eth3/2, [115/400], 0 day/s 00:51:57, isis_fabricpath-default
```

```
DC1-N7K-2# show fabricpath route
FabricPath Unicast Route Table
'a/b/c' denotes ftag/switch-id/subswitch-id
'[x/y]' denotes [admin distance/metric]
ftag 0 is local ftag
subswitch-id 0 is default subswitch-id
```

FabricPath Unicast Route Table for Topology-Default

```
0/4070/0, number of next-hops: 0
    via ---- , [60/0], 0 day/s 01:10:46, local
0/4070/3, number of next-hops: 1
    via sup-eth1, [81/0], 0 day/s 01:10:46, fpoam
1/1802/0, number of next-hops: 2
    via Eth3/9, [115/400], 0 day/s 00:52:24, isis_fabricpath-default
    via Eth3/10, [115/400], 0 day/s 00:52:24, isis_fabricpath-default
1/1868/0, number of next-hops: 1
    via Eth3/13, [115/400], 0 day/s 00:33:36, isis_fabricpath-default
1/3715/0, number of next-hops: 1
    via Eth3/12, [115/400], 0 day/s 00:34:18, isis_fabricpath-default
```

```
DC1-N5K-1# show fabricpath route
FabricPath Unicast Route Table
'a/b/c' denotes ftag/switch-id/subswitch-id
'[x/y]' denotes [admin distance/metric]
ftag 0 is local ftag
subswitch-id 0 is default subswitch-id
```

FabricPath Unicast Route Table for Topology-Default

```
0/3715/0, number of next-hops: 0
    via ---- , [60/0], 0 day/s 02:05:23, local
1/1802/0, number of next-hops: 1
    via Eth1/4, [115/400], 0 day/s 00:34:38, isis_fabricpath-default
1/1868/0, number of next-hops: 2
    via Eth1/1, [115/40], 0 day/s 00:33:56, isis_fabricpath-default
    via Eth1/2, [115/40], 0 day/s 00:33:56, isis_fabricpath-default
1/4070/0, number of next-hops: 1
    via Eth1/12, [115/400], 0 day/s 00:34:38, isis_fabricpath-default
```

```
DC1-N5K-2# show fabricpath route
FabricPath Unicast Route Table
'a/b/c' denotes ftag/switch-id/subswitch-id
'[x/y]' denotes [admin distance/metric]
ftag 0 is local ftag
subswitch-id 0 is default subswitch-id
```

FabricPath Unicast Route Table for Topology-Default

```
0/1868/0, number of next-hops: 0
    via ---- , [60/0], 0 day/s 02:02:53, local
1/1802/0, number of next-hops: 1
    via Eth1/5, [115/400], 0 day/s 00:34:31, isis_fabricpath-default
1/3715/0, number of next-hops: 2
    via Eth1/1, [115/40], 0 day/s 00:34:31, isis_fabricpath-default
    via Eth1/2, [115/40], 0 day/s 00:34:31, isis_fabricpath-default
1/4070/0, number of next-hops: 1
    via Eth1/13, [115/400], 0 day/s 00:34:31, isis_fabricpath-default
```

9. Change the FabricPath Switch-ID.

Remember that Switch-ID is unique in the environment. Initially it is automatically assigned by Switch. However, it can be changed.

Nexus 7K-1

```
DC1-N7K-1# configure terminal
Enter configuration commands, one per line. End with CNTL/Z.
DC1-N7K-1(config)# fabricpath switch-id 71
DC1-N7K-1(config)# end
DC1-N7K-1# show fabricpath switch-id local
Switch-Id: 71
System-Id: 70d3.7963.6ac2
```

Nexus 7K-2

```
DC1-N7K-2# configure terminal
Enter configuration commands, one per line. End with CNTL/Z.
DC1-N7K-2(config)# fabricpath switch-id 72
DC1-N7K-2(config)# end
DC1-N7K-2# show fabricpath switch-id local
Switch-Id: 72
System-Id: 70d3.7963.6ac3
```

Nexus 5K-1

```
DC1-N5K-1# configure terminal
Enter configuration commands, one per line. End with CNTL/Z.
DC1-N5K-1(config)# fabricpath switch-id 51
DC1-N5K-1(config)# end
DC1-N5K-1# show fabricpath switch-id local
Switch-Id: 51
System-Id: 00de.fb73.04bc
```

Nexus 5K-2

```
DC1-N5K-2# configure terminal
Enter configuration commands, one per line. End with CNTL/Z.
DC1-N5K-2(config)# fabricpath switch-id 52
DC1-N5K-2(config)# end
DC1-N5K-2# show fabricpath switch-id local
Switch-Id: 52
System-Id: 00de.fb73.057c
```

10. Verify whether Nexus 7K-1 learnt new Switch-IDs or not.

```

DC1-N7K-1# show fabricpath switch-id
                        FABRICPATH SWITCH-ID TABLE
Legend: '*' - this system
        '[E]' - local Emulated Switch-id
        '[A]' - local Anycast Switch-id
Total Switch-ids: 4
=====
      SWITCH-ID      SYSTEM-ID      FLAGS      STATE      STATIC      EMULATED/
-----+-----+-----+-----+-----+
      51             00de.fb73.04bc  Primary    Confirmed  Yes         No
      52             00de.fb73.057c  Primary    Confirmed  Yes         No
*     71             70d3.7963.6ac2  Primary    Confirmed  Yes         No
      72             70d3.7963.6ac3  Primary    Confirmed  Yes         No
=====

```

Now, we can see that new Switch-IDs are visible. We can understand the fabricpath routing table with ease due to change in switch-id.

```

DC1-N7K-1# show fabricpath route
FabricPath Unicast Route Table
'a/b/c' denotes ftag/switch-id/subswitch-id
'[x/y]' denotes [admin distance/metric]
ftag 0 is local ftag
subswitch-id 0 is default subswitch-id

```

FabricPath Unicast Route Table for Topology-Default

```

0/71/0, number of next-hops: 0
    via ---- , [60/0], 0 day/s 00:09:40, local
0/71/3, number of next-hops: 1
    via sup-eth1, [81/0], 0 day/s 00:09:40, fpoam
1/51/0, number of next-hops: 1
    via Eth3/4, [115/400], 0 day/s 00:07:55, isis_fabricpath-default
1/52/0, number of next-hops: 1
    via Eth3/5, [115/400], 0 day/s 00:07:23, isis_fabricpath-default
1/72/0, number of next-hops: 2
    via Eth3/1, [115/400], 0 day/s 00:08:36, isis_fabricpath-default
    via Eth3/2, [115/400], 0 day/s 00:08:36, isis_fabricpath-default

```

11. Test the Host connectivity in FabricPath

Setup Hosts Server 1(10.1.1.1/24) and Server 2(10.1.1.2/24)

Server 1 is connected to Nexus 5K-1 on Port Eth1/18. Configure it in Vlan 222 (Fabricpath Vlan)

```

DC1-N5K-1# configure terminal
Enter configuration commands, one per line.  End with CNTL/Z.
DC1-N5K-1(config)# interface ethernet 1/18
DC1-N5K-1(config-if)# no shutdown
DC1-N5K-1(config-if)# switchport
DC1-N5K-1(config-if)# switchport mode access
DC1-N5K-1(config-if)# switchport access vlan 222
DC1-N5K-1(config-if)# end
DC1-N5K-1# show interface status | include 1/18
Eth1/18      --                connected 222          full    1000    SFP-1000BAS
DC1-N5K-1# █

```

Now, configure the host Server1 with the IP 10.1.1.1/24. Note that Switch 7K-3 is acting as Server 1 Host.

```

DC1-N7K-Server1# configure terminal
Enter configuration commands, one per line.  End with CNTL/Z.
DC1-N7K-Server1(config)# interface ethernet 3/18
DC1-N7K-Server1(config-if)# ip address 10.1.1.1/24
DC1-N7K-Server1(config-if)# no shutdown
DC1-N7K-Server1(config-if)# end
DC1-N7K-Server1# show ip interface brief | include 3/18
Eth3/18      10.1.1.1          protocol-up/link-up/admin-up
DC1-N7K-Server1# █

```

Server 2 Host is connected to Switch 7K-2 on port 3/11. Configure it in vlan 222 (Fabricpath Vlan)

```

DC1-N7K-2# configure terminal
Enter configuration commands, one per line.  End with CNTL/Z.
DC1-N7K-2(config)# interface ethernet3/11
DC1-N7K-2(config-if)# no shutdown
DC1-N7K-2(config-if)# switchport
DC1-N7K-2(config-if)# switchport mode access
DC1-N7K-2(config-if)# switchport access vlan 222
DC1-N7K-2(config-if)# end
DC1-N7K-2# show interface status | include 3/11
Eth3/11      --                connected 222          full    a-1000  1000base-T
DC1-N7K-2# █

```

Configure the IP 10.1.1.2/24 on Server 2 . Here 7K-4 Switch is acting as Server 2.

```

DC1-N7K-Server-2# configure terminal
Enter configuration commands, one per line.  End with CNTL/Z.
DC1-N7K-Server-2(config)# interface ethernet 3/25
DC1-N7K-Server-2(config-if)# ip address 10.1.1.2/24
DC1-N7K-Server-2(config-if)# no shutdown
DC1-N7K-Server-2(config-if)# end
DC1-N7K-Server-2# show ip interface brief | include 3/25
Eth3/25      10.1.1.2          protocol-up/link-up/admin-up
DC1-N7K-Server-2# █

```

Here we need to make sure that both Leaf Switches act at Root Bridge for Vlan222. We should setup the same priority on both Leaf switches.

Here Switch 5K-1 is one leaf and 7K-2 is second leaf switch. Setup the priority 8192 on both Leaf switches and check the spanning-tree status for Vlan222.

```
DC1-N5K-1# configure terminal
Enter configuration commands, one per line. End with CNTL/Z.
DC1-N5K-1(config)# spanning-tree vlan 222 priority 8192
DC1-N5K-1(config)# end
DC1-N5K-1# show spanning-tree vlan 222
```

VLAN0222

```
Spanning tree enabled protocol rstp
Root ID    Priority    8414
           Address    c84c.75fa.6000
           This bridge is the root
           Hello Time 2 sec Max Age 20 sec Forward Delay 15 sec

Bridge ID  Priority    8414 (priority 8192 sys-id-ext 222)
           Address    c84c.75fa.6000
           Hello Time 2 sec Max Age 20 sec Forward Delay 15 sec
```

```
Interface          Role Sts Cost      Prio.Nbr Type
-----
Eth1/18            Desg FWD 4         128.146 P2p
```

```
DC1-N7K-2# configure terminal
Enter configuration commands, one per line. End with CNTL/Z.
DC1-N7K-2(config)# spanning-tree vlan 222 priority 8192
DC1-N7K-2(config)# end
DC1-N7K-2# show spanning-tree vlan 222
```

VLAN0222

```
Spanning tree enabled protocol rstp
Root ID    Priority    8414
           Address    c84c.75fa.6000
           This bridge is the root
           Hello Time 2 sec Max Age 20 sec Forward Delay 15 sec

Bridge ID  Priority    8414 (priority 8192 sys-id-ext 222)
           Address    c84c.75fa.6000
           Hello Time 2 sec Max Age 20 sec Forward Delay 15 sec
```

```
Interface          Role Sts Cost      Prio.Nbr Type
-----
Eth3/11            Desg FWD 4         128.395 P2p
```

Test the Ping connectivity

```
DC1-N7K-Server1# ping 10.1.1.2
PING 10.1.1.2 (10.1.1.2): 56 data bytes
64 bytes from 10.1.1.2: icmp_seq=0 ttl=254 time=1.12 ms
64 bytes from 10.1.1.2: icmp_seq=1 ttl=254 time=0.849 ms
64 bytes from 10.1.1.2: icmp_seq=2 ttl=254 time=0.887 ms
64 bytes from 10.1.1.2: icmp_seq=3 ttl=254 time=0.861 ms
64 bytes from 10.1.1.2: icmp_seq=4 ttl=254 time=0.856 ms
^C
--- 10.1.1.2 ping statistics ---
5 packets transmitted, 5 packets received, 0.00% packet loss
round-trip min/avg/max = 0.849/0.914/1.12 ms
DC1-N7K-Server1# █
```

```
DC1-N7K-Server-2# ping 10.1.1.1
PING 10.1.1.1 (10.1.1.1): 56 data bytes
64 bytes from 10.1.1.1: icmp_seq=0 ttl=254 time=1.034 ms
64 bytes from 10.1.1.1: icmp_seq=1 ttl=254 time=0.84 ms
64 bytes from 10.1.1.1: icmp_seq=2 ttl=254 time=0.875 ms
64 bytes from 10.1.1.1: icmp_seq=3 ttl=254 time=0.812 ms
64 bytes from 10.1.1.1: icmp_seq=4 ttl=254 time=0.868 ms
^C
--- 10.1.1.1 ping statistics ---
5 packets transmitted, 5 packets received, 0.00% packet loss
round-trip min/avg/max = 0.812/0.885/1.034 ms
DC1-N7K-Server-2# █
```

Traceroute from Server 1 to 2 and vice-versa.

```
DC1-N7K-Server1# traceroute 10.1.1.2
traceroute to 10.1.1.2 (10.1.1.2), 30 hops max, 40 byte packets
 1 10.1.1.2 (10.1.1.2) 1.099 ms 0.912 ms 0.9 ms
DC1-N7K-Server1#
DC1-N7K-Server1# █
DC1-N7K-Server-2# traceroute 10.1.1.1
traceroute to 10.1.1.1 (10.1.1.1), 30 hops max, 40 byte packets
 1 10.1.1.1 (10.1.1.1) 1.113 ms 0.957 ms 0.862 ms
DC1-N7K-Server-2# █
```

Check the mac-address-table on all four switches.

```
DC1-N7K-1# show mac address-table dynamic vlan 222
```

Note: MAC table entries displayed are getting read from software.
Use the 'hardware-age' keyword to get information related to 'Age'

Legend:

* - primary entry, G - Gateway MAC, (R) - Routed MAC, O - Overlay MAC
age - seconds since last seen,+ - primary entry using vPC Peer-Link, E - EVPN entry
(T) - True, (F) - False , ~~~ - use 'hardware-age' keyword to retrieve age info

VLAN/BD	MAC Address	Type	age	Secure	NTFY	Ports/SWID.SSID.LID
---------	-------------	------	-----	--------	------	---------------------

```
DC1-N7K-1#
```

```
DC1-N5K-2# show mac address-table dynamic vlan 222
```

```
DC1-N5K-2#
```

You can see above that Switches N7K-1 and 5K-2 are not learning the mac addresses of Server 1 and Server 2 due to conversational mac-address learning. However, other two switches will learn the mac addresses which you can see below.

```
DC1-N7K-2# show mac address-table dynamic vlan 222
```

Note: MAC table entries displayed are getting read from software.
Use the 'hardware-age' keyword to get information related to 'Age'

Legend:

* - primary entry, G - Gateway MAC, (R) - Routed MAC, O - Overlay MAC
age - seconds since last seen,+ - primary entry using vPC Peer-Link, E - EVPN entry
(T) - True, (F) - False , ~~~ - use 'hardware-age' keyword to retrieve age info

VLAN/BD	MAC Address	Type	age	Secure	NTFY	Ports/SWID.SSID.LID
---------	-------------	------	-----	--------	------	---------------------

222	70d3.7963.6ac4	dynamic	~~~	F	F	51.0.0
* 222	70d3.7963.6ac5	dynamic	~~~	F	F	Eth3/11

```
DC1-N7K-2#
```

You can see above that Nexus 7K-2 is learning the mac-address of Server 1 from Switch with Switch-ID 51 which belongs to N5K-1.

```
DC1-N5K-1# show mac address-table dynamic vlan 222
```

Legend:

* - primary entry, G - Gateway MAC, (R) - Routed MAC, O - Overlay MAC
age - seconds since last seen,+ - primary entry using vPC Peer-Link

VLAN	MAC Address	Type	age	Secure	NTFY	Ports/SWID.SSID.LID
------	-------------	------	-----	--------	------	---------------------

* 222	70d3.7963.6ac4	dynamic	20	F	F	Eth1/18
* 222	70d3.7963.6ac5	dynamic	30	F	F	72.0.10

```
DC1-N5K-1#
```

You can see above that Nexus 5K-1 is learning the mac-address of Server 2 from Switch with Switch-ID 72 which belongs to N7K-2.

Also, In Fabricpath, all switches will be part of only **area 0**. No scope of multiple areas. Since Fabricpath uses ISIS so it has **AD 115**.

Lab 9 : Configuring SPAN on Nexus 5K Switch

SPAN means Switched Port Analyzer . It is used for copying the Rx/Tx traffic of one port/Vlan and pasting it on other interface where you have server connected which can capture it using Wireshark or Ethereal software. Purpose is for analyzing and monitoring. In this both source and destination ports should be part of same switch or VDC.

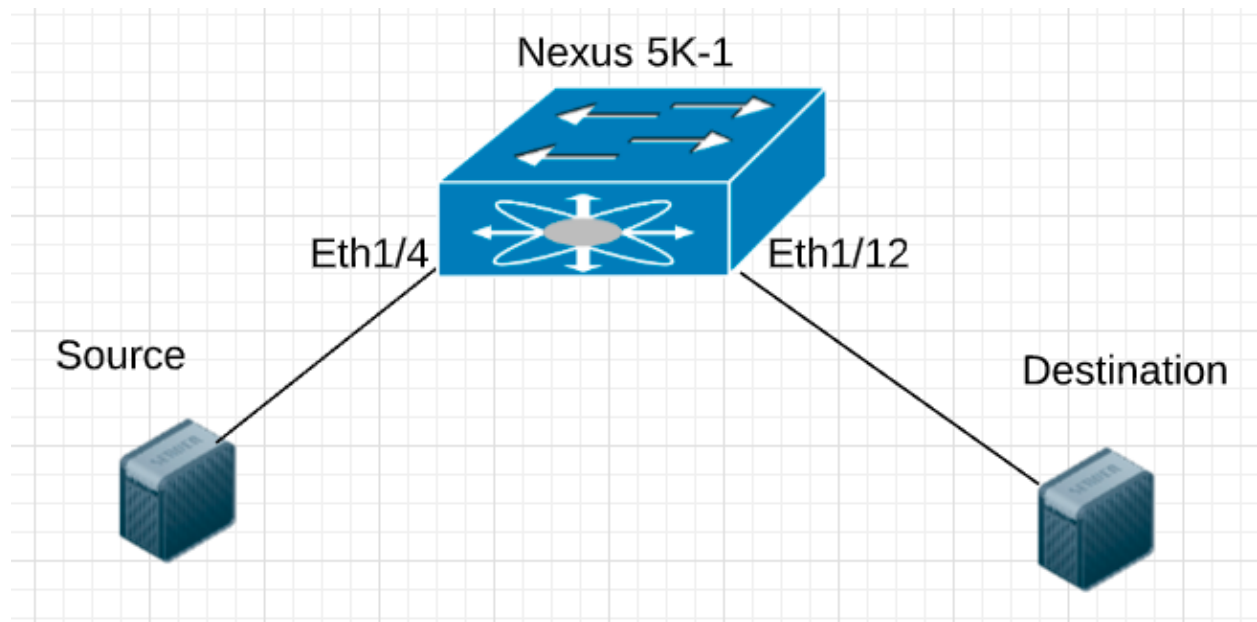

1. Verify the status of Source and Destination port before configuring it for SPAN.

```
DC1-N5K-1# show interface status | include "Eth1/4 "  
Eth1/4      --          connected routed    full    1000    SFP-1000BAS  
DC1-N5K-1# show interface status | include Eth1/12  
Eth1/12    --          connected routed    full    1000    SFP-1000BAS  
DC1-N5K-1# █
```

2. Setup Destination port in "Monitor" mode.

```
DC1-N5K-1# configure terminal  
Enter configuration commands, one per line.  End with CNTL/Z.  
DC1-N5K-1(config)# interface ethernet1/12  
DC1-N5K-1(config-if)# switchport  
DC1-N5K-1(config-if)# switchport monitor  
DC1-N5K-1(config-if)# no shutdown  
DC1-N5K-1(config-if)# end  
DC1-N5K-1# █
```

3. Setup SPAN monitor session in Nexus 5K Switch.

```
DC1-N5K-1(config-monitor)# end
DC1-N5K-1# configure terminal
Enter configuration commands, one per line. End with CNTL/Z.
DC1-N5K-1(config)# monitor session 1
DC1-N5K-1(config-monitor)# source interface ethernet 1/4 rx
DC1-N5K-1(config-monitor)# destination interface ethernet1/12
DC1-N5K-1(config-monitor)# no shut
DC1-N5K-1(config-monitor)# end
DC1-N5K-1# █
```

4. Verify SPAN monitor session.

```
DC1-N5K-1# show monitor session 1
  session 1
-----
type           : local
state          : up
acl-name       : acl-name not specified
source intf    :
  rx           : Eth1/4
  tx           :
  both         :
source VLANs   :
  rx           :
source VSANs   :
  rx           :
destination ports : Eth1/12
```

Legend: f = forwarding enabled, l = learning enabled

Above you can see that SPAN is correctly configured and showing as up.

5. Now, add one more source in SPAN. Add vlan 1 and 222 so that traffic of these two Vlan's get copied to same destination port.

```
DC1-N5K-1# configure terminal
Enter configuration commands, one per line. End with CNTL/Z
DC1-N5K-1(config)# monitor session 1
DC1-N5K-1(config-monitor)# source vlan 1,222
DC1-N5K-1(config-monitor)# end
DC1-N5K-1# █
```

6. Verify the SPAN session.

```
DC1-N5K-1# show monitor session 1
  session 1
-----
type           : local
state          : up
acl-name       : acl-name not specified
source intf    :
  rx           : Eth1/4
  tx           :
  both         :
source VLANs   :
  rx           : 1,222
source VSANs   :
  rx           :
destination ports : Eth1/12
```

Legend: f = forwarding enabled, l = learning enabled

7. Limit the MTU of source frames to 200 Bytes instead of copying the complete frame.

```
DC1-N5K-1# configure terminal
Enter configuration commands, one per line.  End with CNTL/Z.
DC1-N5K-1(config)# monitor session 1
DC1-N5K-1(config-monitor)# mtu 200
DC1-N5K-1(config-monitor)# end
DC1-N5K-1# show monitor session 1
  session 1
-----
type           : local
state          : up
acl-name       : acl-name not specified
mtu            : 200
source intf    :
  rx           : Eth1/4
  tx           :
  both         :
source VLANs   :
  rx           : 1,222
source VSANs   :
  rx           :
destination ports : Eth1/12
```

Legend: f = forwarding enabled, l = learning enabled

```
DC1-N5K-1# █
```

Kindly note that You will see more options in SPAN when you configure in Nexus 7K such as filtering bpd traffic etc.

I did this test on Nexus 5K. Functionality is same and configuration is really simple.

Lab 10 : Configuring ERSPAN on Nexus 7K Switch

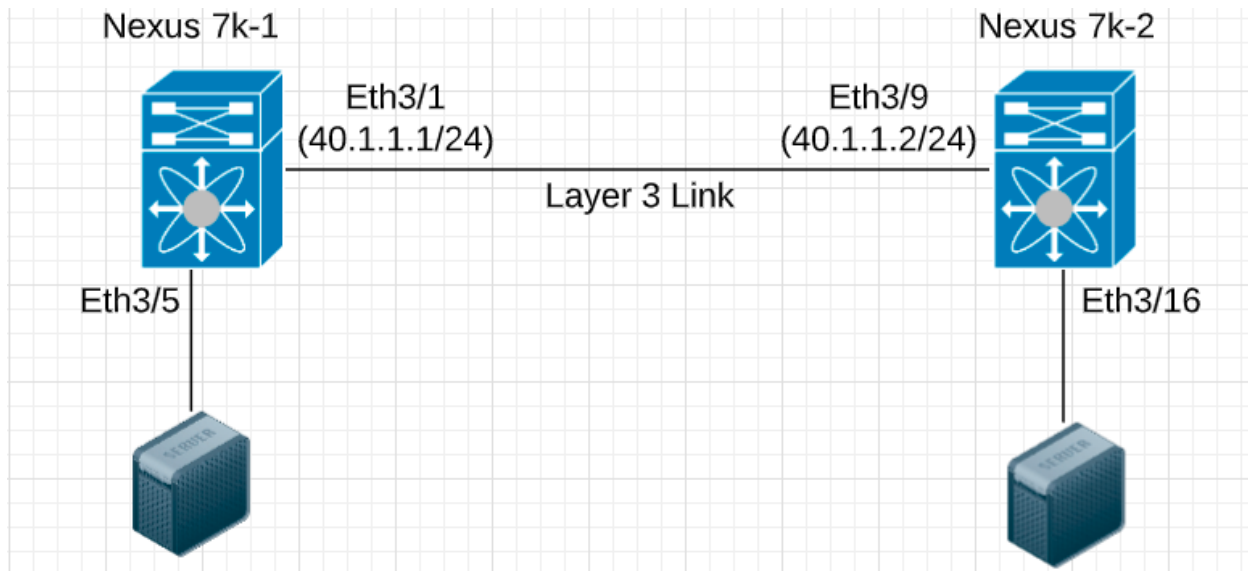

ERSPAN Stands for Encapsulated Remote Switched Port Analyzer. It means Your Source port and destination port will be part of different switches and these switches will be separated by Layer 3. It is advanced state of Remote SPAN. Purpose is to copy the traffic from source to destination server for analyzing logs using Wireshark or Ethereal software.

ERSPAN uses GRE tunnel in background to transfer traffic from source switch to destination.

Kindly Note that If you are using Nexus 7K for ERSPAN then you need to configure one ERSPAN command in **Admin VDC**. While It is not required in case you are using 5K switches for ERSPAN.

1. Configure ERSPAN configuration on Nexus 7K-1, Nexus 7K-2 and Admin VDC.

On Nexus 7K-1 - Source SPAN

```
DC1-N7K-1# configure terminal
Enter configuration commands, one per line. End with CNTL/Z.
DC1-N7K-1(config)# interface ethernet 3/1
DC1-N7K-1(config-if)# ip address 40.1.1.1/24
DC1-N7K-1(config-if)# no shutdown
DC1-N7K-1(config-if)# exit
DC1-N7K-1(config)# monitor session 1 type erspan-source
DC1-N7K-1(config-erspan-src)# erspan-id 100
DC1-N7K-1(config-erspan-src)# vrf default
DC1-N7K-1(config-erspan-src)# source interface ethernet 3/5 both
DC1-N7K-1(config-erspan-src)# destination ip 40.1.1.2
DC1-N7K-1(config-erspan-src)# no shut
DC1-N7K-1(config-erspan-src)# end
DC1-N7K-1#
```

On Nexus 7K (Admin VDC)- Very Important step to know

```
DC1-N7K# configure terminal
Enter configuration commands, one per line. End with CNTL/Z.
DC1-N7K(config)# monitor erspan origin ip-address 40.1.1.1 global
DC1-N7K(config)# end
DC1-N7K# █
```

On Nexus 7K-2 – Destination SPAN

```
DC1-N7K-2# configure terminal
Enter configuration commands, one per line. End with CNTL/Z.
DC1-N7K-2(config)# interface ethernet 3/9
DC1-N7K-2(config-if)# ip address 40.1.1.2/24
DC1-N7K-2(config-if)# no shutdown
DC1-N7K-2(config-if)# end
DC1-N7K-2# configure terminal
Enter configuration commands, one per line. End with CNTL/Z.
DC1-N7K-2(config)# interface ethernet 3/9
DC1-N7K-2(config-if)# ip address 40.1.1.2/24
DC1-N7K-2(config-if)# no shutdown
DC1-N7K-2(config-if)# exit
DC1-N7K-2(config)# monitor session 1 type erspan-destination
DC1-N7K-2(config-erspan-dst)# erspan-id 100
DC1-N7K-2(config-erspan-dst)# vrf default
DC1-N7K-2(config-erspan-dst)# destination interface ethernet 3/16
DC1-N7K-2(config-erspan-dst)# source ip 40.1.1.2
DC1-N7K-2(config-erspan-dst)# no shut
DC1-N7K-2(config-erspan-dst)# end
DC1-N7K-2# █
```

2. Test the Ping connectivity between Nexus 7K-1 and 2.

```
DC1-N7K-1# ping 40.1.1.2
PING 40.1.1.2 (40.1.1.2): 56 data bytes
64 bytes from 40.1.1.2: icmp_seq=0 ttl=254 time=2.742 ms
64 bytes from 40.1.1.2: icmp_seq=1 ttl=254 time=2.15 ms
64 bytes from 40.1.1.2: icmp_seq=2 ttl=254 time=2.195 ms
64 bytes from 40.1.1.2: icmp_seq=3 ttl=254 time=2.178 ms
64 bytes from 40.1.1.2: icmp_seq=4 ttl=254 time=2.23 ms

--- 40.1.1.2 ping statistics ---
5 packets transmitted, 5 packets received, 0.00% packet loss
round-trip min/avg/max = 2.15/2.299/2.742 ms
DC1-N7K-1# █
```

```
DC1-N7K-2# ping 40.1.1.1
PING 40.1.1.1 (40.1.1.1): 56 data bytes
64 bytes from 40.1.1.1: icmp_seq=0 ttl=254 time=2.749 ms
64 bytes from 40.1.1.1: icmp_seq=1 ttl=254 time=2.083 ms
64 bytes from 40.1.1.1: icmp_seq=2 ttl=254 time=2.09 ms
64 bytes from 40.1.1.1: icmp_seq=3 ttl=254 time=2.05 ms
64 bytes from 40.1.1.1: icmp_seq=4 ttl=254 time=2.085 ms

--- 40.1.1.1 ping statistics ---
5 packets transmitted, 5 packets received, 0.00% packet loss
round-trip min/avg/max = 2.05/2.211/2.749 ms
DC1-N7K-2#
```

3. Verify ERSPAN monitor session on Nexus 7K-1 and 2.

```
DC1-N7K-1# show monitor session 1 brief
  session 1
-----
type           : erspan-source
state          : up
erspan-id      : 100
vrf-name       : default
ip-ttl         : 255
ip-dscp        : 0
destination-ip : 40.1.1.2
origin-ip      : 40.1.1.1 (global)
source intf    :
  rx           : Eth3/5
  tx           : Eth3/5
  both         : Eth3/5
source exception :
```

```
DC1-N7K-2# show monitor session 1 brief
session 1
```

```
-----
type           : erspan-destination
state          : up
erspan-id      : 100
vrf-name       : default
source-ip      : 40.1.1.2
destination ports : Eth3/16
```

Feature	Enabled	Value	Modules Supported	Modules Not-Supported
Type-II	Yes	-	3	1
Type-III	Yes	-	3	1

```
DC1-N7K-2# █
```

4. Verify whether the Traffic from Source Port at Nexus 7K-1 is being copied to Destination Port of Nexus 7K-2?

```
DC1-N7K-1# show int e3/5 | i "30 seconds"
```

```
Load-Interval #1: 30 seconds
30 seconds input rate 336 bits/sec, 0 packets/sec
30 seconds output rate 48 bits/sec, 0 packets/sec
```

```
DC1-N7K-1# show int e3/5 | i "30 seconds"
```

```
Load-Interval #1: 30 seconds
30 seconds input rate 13696 bits/sec, 15 packets/sec
30 seconds output rate 13224 bits/sec, 15 packets/sec
```

```
DC1-N7K-1# show int e3/5 | i "30 seconds"
```

```
Load-Interval #1: 30 seconds
30 seconds input rate 59648 bits/sec, 67 packets/sec
30 seconds output rate 59120 bits/sec, 67 packets/sec
```

```
DC1-N7K-1# show int e3/5 | i "30 seconds"
```

```
Load-Interval #1: 30 seconds
30 seconds input rate 86984 bits/sec, 99 packets/sec
30 seconds output rate 86104 bits/sec, 98 packets/sec
```

```
DC1-N7K-1# show int e3/5 | i "30 seconds"
```

```
Load-Interval #1: 30 seconds
30 seconds input rate 82712 bits/sec, 96 packets/sec
30 seconds output rate 81840 bits/sec, 95 packets/sec
```

```
DC1-N7K-1# show int e3/5 | i "30 seconds"
```

```
Load-Interval #1: 30 seconds
30 seconds input rate 87808 bits/sec, 101 packets/sec
30 seconds output rate 87000 bits/sec, 100 packets/sec
```

You can notice above that Source Traffic gradually increased.

```

DC1-N7K-2# show int e3/16 | i "30 seconds"
  Load-Interval #1: 30 seconds
    30 seconds input rate 0 bits/sec, 0 packets/sec
    30 seconds output rate 392 bits/sec, 0 packets/sec
DC1-N7K-2# show int e3/16 | i "30 seconds"
  Load-Interval #1: 30 seconds
    30 seconds input rate 0 bits/sec, 0 packets/sec
    30 seconds output rate 66712 bits/sec, 79 packets/sec
DC1-N7K-2# show int e3/16 | i "30 seconds"
  Load-Interval #1: 30 seconds
    30 seconds input rate 0 bits/sec, 0 packets/sec
    30 seconds output rate 144536 bits/sec, 171 packets/sec
DC1-N7K-2# show int e3/16 | i "30 seconds"
  Load-Interval #1: 30 seconds
    30 seconds input rate 0 bits/sec, 0 packets/sec
    30 seconds output rate 186400 bits/sec, 222 packets/sec
DC1-N7K-2# show int e3/16 | i "30 seconds"
  Load-Interval #1: 30 seconds
    30 seconds input rate 0 bits/sec, 0 packets/sec
    30 seconds output rate 182328 bits/sec, 216 packets/sec
DC1-N7K-2# show int e3/16 | i "30 seconds"
  Load-Interval #1: 30 seconds
    30 seconds input rate 0 bits/sec, 0 packets/sec
    30 seconds output rate 169872 bits/sec, 202 packets/sec

```

Now, in above snapshot you can clearly see that destination port started receiving the traffic which increased proportionately . It means that ERSPAN was correctly configured.

Source Traffic include Rx and Tx. Therefore, Destination Port received double traffic .

Lab 11 : Configuring RSPAN on Nexus 7K Switch

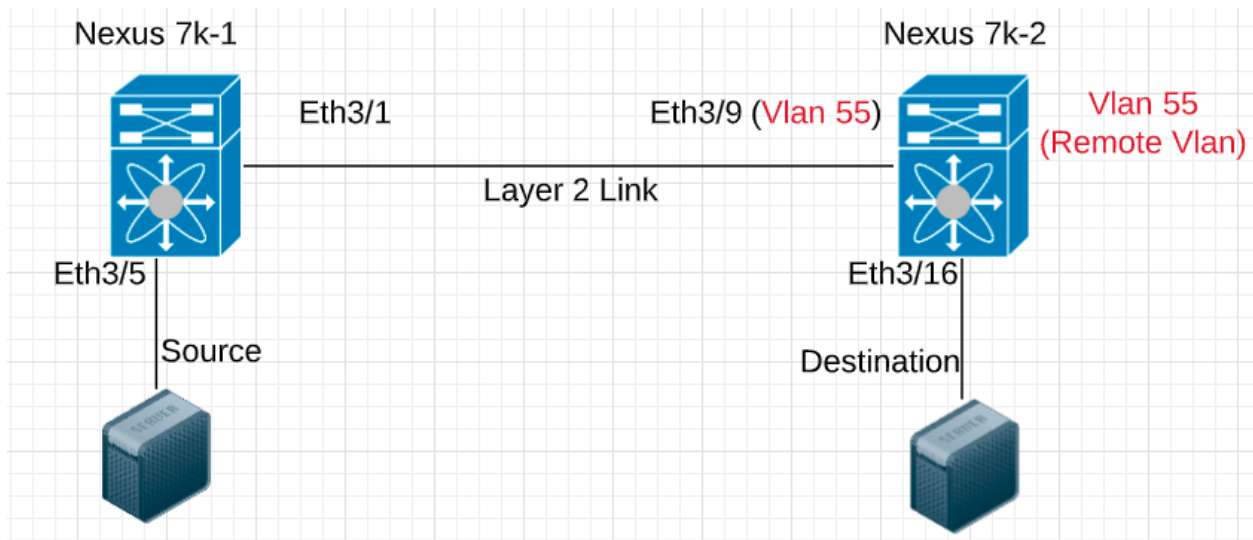

RSPAN stands for Remote Switched Port Analyzer. It is used when our Source port is on one switch and destination port is on another switch, provided both switches are part of same LAN.

Here we need to use a vlan 55 aka remote-vlan, we need to make E3/1 as destination monitoring port on and source port as E3/5 on switch 1.

We need to configure port 3/9 of switch 2 in vlan 55 and then need to make vlan 55 as remote-vlan with a command. Port e3/16 will be destination port.

You will notice that RSPAN configuration is bit different in Nexus as compared to catalyst switches. In catalyst switches, we used to make remote vlan as destination monitoring on switch 1 and then same remote vlan as source on switch 2. In nexus, this is not the case, It will work as below.

1. Configure Nexus Switch 1 and 2 with RSPAN configuration.

Nexus 7K-1

```
DC1-N7K-1# configure terminal
Enter configuration commands, one per line.  End with CNTL/Z.
DC1-N7K-1(config)# interface ethernet 3/1
DC1-N7K-1(config-if)# switchport
DC1-N7K-1(config-if)# switchport monitor
DC1-N7K-1(config-if)# no shutdown
DC1-N7K-1(config-if)# exit
DC1-N7K-1(config)# monitor session 1
DC1-N7K-1(config-monitor)# source interface ethernet 3/5
DC1-N7K-1(config-monitor)# destination interface ethernet 3/1
DC1-N7K-1(config-monitor)# no shut
DC1-N7K-1(config-monitor)# end
DC1-N7K-1#
```

Nexus 7K-2

```
DC1-N7K-2# configure terminal
Enter configuration commands, one per line.  End with CNTL/Z.
DC1-N7K-2(config)# vlan 55
DC1-N7K-2(config-vlan)# remote-span
DC1-N7K-2(config-vlan)# exit
DC1-N7K-2(config)# interface ethernet 3/16
DC1-N7K-2(config-if)# switchport
DC1-N7K-2(config-if)# switchport monitor
DC1-N7K-2(config-if)# no shutdown
DC1-N7K-2(config-if)# exit
DC1-N7K-2(config)# monitor session 1
DC1-N7K-2(config-monitor)# source vlan 55
DC1-N7K-2(config-monitor)# destination interface e3/16
DC1-N7K-2(config-monitor)# no shut
DC1-N7K-2(config-monitor)# end
DC1-N7K-2#
```

2. Verify the monitor session 1 on both nexus 7k-1 and 7k-2

On Nexus 7K-1

```
DC1-N7K-1# show monitor session 1 brief
  session 1
```

```
-----
type           : local
state          : up
source intf    :
  rx           : Eth3/5
  tx           : Eth3/5
  both         : Eth3/5
source exception :
destination ports : Eth3/1
```

On Nexus 7K-2

```
DC1-N7K-2# show monitor session 1 brief
  session 1
```

```
-----
type           : local
state          : up
source VLANs   :
  rx           : 55
  tx           : 55
  both         : 55
source exception :
destination ports : Eth3/16
```

3. Now, generate traffic on Interface e3/5 of N7K-1 and see whether it is being copied to N7K-2 interface e3/16?

Source Port

```
DC1-N7K-1# show interface ethernet 3/5 | section "30 seconds"
Load-Interval #1: 30 seconds
 30 seconds input rate 64 bits/sec, 0 packets/sec
 30 seconds output rate 64 bits/sec, 0 packets/sec
input rate 64 bps, 0 pps; output rate 64 bps, 0 pps
DC1-N7K-1# show interface ethernet 3/5 | section "30 seconds"
Load-Interval #1: 30 seconds
 30 seconds input rate 29464 bits/sec, 1 packets/sec
 30 seconds output rate 22112 bits/sec, 1 packets/sec
input rate 29.46 Kbps, 1 pps; output rate 22.11 Kbps, 1 pps
DC1-N7K-1# show interface ethernet 3/5 | section "30 seconds"
Load-Interval #1: 30 seconds
 30 seconds input rate 48136 bits/sec, 3 packets/sec
 30 seconds output rate 36208 bits/sec, 2 packets/sec
input rate 48.14 Kbps, 3 pps; output rate 36.21 Kbps, 2 pps
DC1-N7K-1# show interface ethernet 3/5 | section "30 seconds"
Load-Interval #1: 30 seconds
 30 seconds input rate 60272 bits/sec, 4 packets/sec
 30 seconds output rate 45368 bits/sec, 3 packets/sec
input rate 60.27 Kbps, 4 pps; output rate 45.37 Kbps, 3 pps
DC1-N7K-1# show interface ethernet 3/5 | section "30 seconds"
Load-Interval #1: 30 seconds
 30 seconds input rate 68192 bits/sec, 6 packets/sec
 30 seconds output rate 51344 bits/sec, 5 packets/sec
input rate 68.19 Kbps, 6 pps; output rate 51.34 Kbps, 5 pps
DC1-N7K-1# █
```

Destination Port

```

DC1-N7K-2# show interface ethernet 3/16 | section "30 seconds"
Load-Interval #1: 30 seconds
 30 seconds input rate 0 bits/sec, 0 packets/sec
 30 seconds output rate 336 bits/sec, 0 packets/sec
input rate 0 bps, 0 pps; output rate 336 bps, 0 pps
DC1-N7K-2# show interface ethernet 3/16 | section "30 seconds"
Load-Interval #1: 30 seconds
 30 seconds input rate 0 bits/sec, 0 packets/sec
 30 seconds output rate 149888 bits/sec, 10 packets/sec
input rate 0 bps, 0 pps; output rate 149.89 Kbps, 10 pps
DC1-N7K-2# show interface ethernet 3/16 | section "30 seconds"
Load-Interval #1: 30 seconds
 30 seconds input rate 0 bits/sec, 0 packets/sec
 30 seconds output rate 168968 bits/sec, 12 packets/sec
input rate 0 bps, 0 pps; output rate 168.97 Kbps, 12 pps
DC1-N7K-2# show interface ethernet 3/16 | section "30 seconds"
Load-Interval #1: 30 seconds
 30 seconds input rate 0 bits/sec, 0 packets/sec
 30 seconds output rate 222272 bits/sec, 15 packets/sec
input rate 0 bps, 0 pps; output rate 222.27 Kbps, 15 pps
DC1-N7K-2# show interface ethernet 3/16 | section "30 seconds"
Load-Interval #1: 30 seconds
 30 seconds input rate 0 bits/sec, 0 packets/sec
 30 seconds output rate 256760 bits/sec, 15 packets/sec
input rate 0 bps, 0 pps; output rate 256.76 Kbps, 15 pps
DC1-N7K-2# █

```

Above you can see that traffic got copied.

Lab 12 : Setting Checkpoints in Nexus Switches

Whenever you do configuration change on nexus switches, it is recommended that you set up checkpoint so that you can return to the last saved configuration if situation demands. It basically copies the running config to temporary file . This file will be deleted when reload happens.

1. Create one checkpoint.

```

DC1-N7K-1# checkpoint CP1
Done

```

2. Verify the checkpoint.

```
DC1-N7K-1# show checkpoint CP1
```

```
-----  
Name: CP1
```

```
!Command: Checkpoint cmd vdc 2  
!Time: Wed Aug 14 19:53:40 2019
```

```
version 8.0(1)  
feature-set fabricpath  
hostname 1
```

```
cfs eth distribute  
feature lacp  
feature vpc
```

3. Make some changes in the nexus switch now.

```
DC1-N7K-1# configure terminal
```

```
Enter configuration commands, one per line. End with CNTL/Z.
```

```
DC1-N7K-1(config)# vlan 1000
```

```
DC1-N7K-1(config-vlan)# name Ashish-CP1
```

```
DC1-N7K-1(config-vlan)# end
```

4. Now, find out what changes were made since the creation of previous checkpoint CP1

```
DC1-N7K-1# show diff rollback-patch checkpoint CP1 running-config
```

```
Collecting Running-Config  
#Generating Rollback Patch
```

```
!!
```

```
!
```

```
vlan 1000
```

```
name Ashish-CP1
```

```
DC1-N7K-1# █
```

Above you can see the difference of configuration from last saved checkpoint CP1. Note that maximum 10 checkpoints can be created.

Global changes which are done at Admin VDC level can't be recovered using Checkpoint.

5. How to delete the checkpoint?

```
DC1-N7K-1# no checkpoint CP1
```

```
Done
```

```
DC1-N7K-1# █
```

6. How to **Rollback** to the previously set checkpoint? Create one checkpoint CP1 and make some changes and then verify the difference of config.

```
DC1-N7K-1# checkpoint CP1
```

```
Done
```

```
DC1-N7K-1# configure terminal
```

```
Enter configuration commands, one per line. End with CNTL/Z.
```

```
DC1-N7K-1(config)# vlan 333
```

```
DC1-N7K-1(config-vlan)# exit
```

```
DC1-N7K-1(config)# feature interface-vlan
```

```
DC1-N7K-1(config)# interface vlan 333
```

```
DC1-N7K-1(config-if)# ip add 60.1.1.1/24
```

```
DC1-N7K-1(config-if)# no shutdown
```

```
DC1-N7K-1(config-if)# end
```

```
DC1-N7K-1# █
```

```
DC1-N7K-1# show diff rollback-patch checkpoint CP1 running-config
Collecting Running-Config
#Generating Rollback Patch
```

```
!!
!
feature interface-vlan
!
vlan 333
!
interface Vlan1
!
interface Vlan333
no shutdown
ip address 60.1.1.1/24
```

```
DC1-N7K-1# █
```

now, let's **Rollback** the configuration to checkpoint **CP1**.

```
DC1-N7K-1# rollback running-config checkpoint CP1
Note: Applying config parallely may fail Rollback verification
Collecting Running-Config
#Generating Rollback Patch
Executing Rollback Patch
Generating Running-config for verification
Generating Patch for verification
Verification is Successful.
```

Rollback completed successfully.

```
DC1-N7K-1# █
```

Now, check if we have Vlan333 available as well as feature interface-vlan ?

```

DC1-N7K-1# show feature | include interface-vlan
interface-vlan      1      disabled
DC1-N7K-1# show run interface vlan333
                    ^
Invalid interface format at '^' marker.
DC1-N7K-1# show diff rollback-patch checkpoint CP1 running-config
Collecting Running-Config
#Generating Rollback Patch
Rollback Patch is Empty
DC1-N7K-1# █

```

Above, you can see that changes were reverted due to rollback command. Rollback command does not delete the checkpoint file. It only deletes the content of the file. You can create multiple checkpoints and compare these.

7. Create multiple checkpoints and compare the configuration changes in the checkpoint using some comparison method.

```

DC1-N7K-1# checkpoint CP2
Done
DC1-N7K-1# configure terminal
Enter configuration commands, one per line.  End with CNTL/Z.
DC1-N7K-1(config)# vlan 92
DC1-N7K-1(config-vlan)# name CP3-test
DC1-N7K-1(config-vlan)# end
DC1-N7K-1# checkpoint CP3
Done
DC1-N7K-1# configure terminal
Enter configuration commands, one per line.  End with CNTL/Z.
DC1-N7K-1(config)# vlan 102
DC1-N7K-1(config-vlan)# name CP4-test
DC1-N7K-1(config-vlan)# end
DC1-N7K-1# checkpoint CP4
Done
DC1-N7K-1# configure terminal
Enter configuration commands, one per line.  End with CNTL/Z.
DC1-N7K-1(config)# interface vlan 102
DC1-N7K-1(config-if)# ip address 102.1.1.1/24
DC1-N7K-1(config-if)# no shutdown
DC1-N7K-1(config-if)# end
DC1-N7K-1# checkpoint CP5
Done
DC1-N7K-1# █

```

Now, let's check the difference using "show diff" command

```
DC1-N7K-1# show diff rollback-patch checkpoint CP3 checkpoint CP5
#Generating Rollback Patch

!!

!

vlan 102

    name CP4-test

exit

!

interface Vlan102

    no shutdown

    ip address 102.1.1.1/24
```

```
DC1-N7K-1# show diff rollback-patch checkpoint CP3 checkpoint CP4
#Generating Rollback Patch
```

```
!!
```

```
!
```

```
vlan 102
```

```
name CP4-test
```

```
DC1-N7K-1# show diff rollback-patch checkpoint CP2 checkpoint CP5
#Generating Rollback Patch
```

```
!!
```

```
!
```

```
vlan 92
```

```
name CP3-test
```

```
exit
```

```
!
```

```
vlan 102
```

```
name CP4-test
```

```
exit
```

```
!
```

```
interface Vlan102
```

```
no shutdown
```

```
ip address 102.1.1.1/24
```

```
DC1-N7K-1# █
```

Above, you can see the difference in configuration between checkpoints.

Lab 13 : Use Wireshark to Nexus Switches

1. Capture the control plane traffic on Nexus 7000.

```
DC1-N7K-1# ethanalyzer local interface inband
Capturing on inband
2019-08-14 21:18:27.975665 CtrixsIn_02:00:00 -> PVST+          STP 64 RST. Root =
32768/55/70:d3:79:63:6a:c3 Cost = 0 Port = 0x90c7
2019-08-14 21:18:27.975843 00:f8:2c:90:ac:04 -> Spanning-tree-(for-bridges)_00 S
TP 60 RST. Root = 32768/55/70:d3:79:63:6a:c3 Cost = 0 Port = 0x8189
3 2019-08-14 21:18:28.468097 Cisco_73:04:73 -> Spanning-tree-(for-bridges)_00 ST
P
60 RST. Root = 32768/1/00:de:fb:73:04:bc Cost = 0 Port = 0x9063
2019-08-14 21:18:28.468141 Cisco_73:04:73 -> PVST+          STP 64 RST. Root = 32768/1
2019-08-14 21:18:28.692901 Cisco_73:05:2c -> CDP/VTP/DTP/PAgP/UDLD CDP 265 Device II
2019-08-14 21:18:28.692923 Cisco_73:05:2c -> CDP/VTP/DTP/PAgP/UDLD CDP 265 Device II
2019-08-14 21:18:28.968045 Cisco_73:04:73 -> PVST+          STP 64 RST. Root = 8192/22
2019-08-14 21:18:28.968064 Cisco_73:04:79 -> Spanning-tree-(for-bridges)_00 STP 60 F
9 2019-08-14 21:18:28.975822 CtrixsIn_02:00:00 -> PVST+          STP 64 RST. Root = 81
10 2019-08-14 21:18:28.975969 CtrixsIn_01:00:00 -> PVST+          STP 64 RST. Root = 8
```

DC1-N7K-1# █

Above command will capture the incoming and outgoing packets of CPU . By default, it captures 10 packets.

2. Capture only the incoming packets of CPU.

```
DC1-N7K-1# ethanalyzer local interface inband-in
Capturing on inband
2019-08-14 21:21:59.384688 Cisco_73:05:34 -> Spanning-tree-(for-bridges)_00 STP 60 RST. Rc
2019-08-14 21:21:59.384730 Cisco_73:05:34 -> PVST+          STP 64 RST. Root = 32768/1/00:de
3 2019-08-14 21:21:59.384898 Cisco_73:05:34 -> PVST+          STP 64 RST. Root = 32768/222/c
4 2019-08-14 21:21:59.806452 Cisco_73:04:73 -> LLDP_Multicast LLDP 339 Chassis Id = 00:de:
2019-08-14 21:22:00.446236 Cisco_73:04:73 -> Spanning-tree-(for-bridges)_00 STP 60 RST. Rc
2019-08-14 21:22:00.446472 Cisco_73:04:73 -> PVST+          STP 64 RST. Root = 32768/1/00:de
7 2019-08-14 21:22:00.946298 Cisco_73:04:73 -> PVST+          STP 64 RST. Root = 8192/222/cE
2019-08-14 21:22:00.946503 Cisco_73:04:79 -> Spanning-tree-(for-bridges)_00 STP 60 RST. Rc
2019-08-14 21:22:01.384595 Cisco_73:05:34 -> Spanning-tree-(for-bridges)_00 STP 60 RST. Rc
10 2019-08-14 21:22:01.384616 Cisco_73:05:34 -> PVST+          STP 64 RST. Root = 32768/1/00
```

DC1-N7K-1# █

3. Capture the outbound CPU traffic (only 4 packets). Command is "limit-captured-frames "

```
DC1-N7K-1# ethanalyzer local interface inband-out limit-captured-frames 4
Capturing on inband
1 2019-08-14 21:22:56.983001 CtrixsIn_02:00:00 -> PVST+          STP 64 RST. Root = 819
2019-08-14 21:22:56.983130 CtrixsIn_01:00:00 -> PVST+          STP 64 RST. Root = 8192/
3 2019-08-14 21:22:56.983299 00:f8:2c:90:ac:06 -> Spanning-tree-(for-bridges)_00 STP
4 2019-08-14 21:22:57.983873 CtrixsIn_02:00:00 -> PVST+          STP 64 RST. Root = 327
```

DC1-N7K-1# █

4. Filter the traffic of host 50.1.1.1 which is being sent and received by CPU , but only 13 packets.

```

DC1-N7K-1# ethanalyzer local interface inband capture-filter "host 50.1.1.1" limit-captured-frames 13
Capturing on inband
2019-08-14 21:30:44.315316      50.1.1.2 -> 50.1.1.1      ICMP 98 Echo (ping) request id=0xf945, seq=0/0, ttl=255
2019-08-14 21:30:44.315689      50.1.1.1 -> 50.1.1.2      ICMP 98 Echo (ping) reply id=0xf945, seq=0/0, ttl=255 (req
2019-08-14 21:30:44.316404      50.1.1.2 -> 50.1.1.1      ICMP 98 Echo (ping) request id=0xf945, seq=256/1, ttl=255
2019-08-14 21:30:44.316661      50.1.1.1 -> 50.1.1.2      ICMP 98 Echo (ping) reply id=0xf945, seq=256/1, ttl=255 (r
2019-08-14 21:30:44.317456      50.1.1.2 -> 50.1.1.1      ICMP 98 Echo (ping) request id=0xf945, seq=512/2, ttl=255
2019-08-14 21:30:44.317706      50.1.1.1 -> 50.1.1.2      ICMP 98 Echo (ping) reply id=0xf945, seq=512/2, ttl=255 (r
2019-08-14 21:30:44.318482      50.1.1.2 -> 50.1.1.1      ICMP 98 Echo (ping) request id=0xf945, seq=768/3, ttl=255
2019-08-14 21:30:44.318733      50.1.1.1 -> 50.1.1.2      ICMP 98 Echo (ping) reply id=0xf945, seq=768/3, ttl=255 (r
2019-08-14 21:30:44.319870      50.1.1.2 -> 50.1.1.1      ICMP 98 Echo (ping) request id=0xf945, seq=1024/4, ttl=255
2019-08-14 21:30:44.320137      50.1.1.1 -> 50.1.1.2      ICMP 98 Echo (ping) reply id=0xf945, seq=1024/4, ttl=255 (
2019-08-14 21:30:44.320898      50.1.1.2 -> 50.1.1.1      ICMP 98 Echo (ping) request id=0xf945, seq=1280/5, ttl=255
2019-08-14 21:30:44.321149      50.1.1.1 -> 50.1.1.2      ICMP 98 Echo (ping) reply id=0xf945, seq=1280/5, ttl=255 (
13 2019-08-14 21:30:44.321941      50.1.1.2 -> 50.1.1.1      ICMP 98 Echo (ping) request id=0xf945, seq=1536/6, ttl=25

```

```
DC1-N7K-1#
```

5. Filter the traffic for Network 50.1.1.0/24.

```

DC1-N7K-1# ethanalyzer local interface inband capture-filter "net 50.1.1.0/24"
Capturing on inband
2019-08-14 21:32:49.473809      50.1.1.2 -> 50.1.1.1      ICMP 98 Echo (ping) requ
2019-08-14 21:32:49.474172      50.1.1.1 -> 50.1.1.2      ICMP 98 Echo (ping) repl
2019-08-14 21:32:49.474859      50.1.1.2 -> 50.1.1.1      ICMP 98 Echo (ping) requ
2019-08-14 21:32:49.475115      50.1.1.1 -> 50.1.1.2      ICMP 98 Echo (ping) repl
2019-08-14 21:32:49.475708      50.1.1.2 -> 50.1.1.1      ICMP 98 Echo (ping) requ
2019-08-14 21:32:49.475986      50.1.1.1 -> 50.1.1.2      ICMP 98 Echo (ping) repl
2019-08-14 21:32:49.476592      50.1.1.2 -> 50.1.1.1      ICMP 98 Echo (ping) requ
2019-08-14 21:32:49.476850      50.1.1.1 -> 50.1.1.2      ICMP 98 Echo (ping) repl
2019-08-14 21:32:49.477411      50.1.1.2 -> 50.1.1.1      ICMP 98 Echo (ping) requ
10 2019-08-14 21:32:49.477664      50.1.1.1 -> 50.1.1.2      ICMP 98 Echo (ping) r

```

```
DC1-N7K-1#
```

Note, Above, you can use the keyword "mask 255.255.255.0" instead of /24

6. Now, filter using source ip 50.1.1.2

```

DC1-N7K-1# ethanalyzer local interface inband capture-filter "src 50.1.1.2"
Capturing on inband
2019-08-14 21:36:19.008396      50.1.1.2 -> 50.1.1.1      ICMP 98 Echo (ping) request id=0x6a47, seq=0/0, ttl=255
2019-08-14 21:36:19.009532      50.1.1.2 -> 50.1.1.1      ICMP 98 Echo (ping) request id=0x6a47, seq=256/1, ttl=255
2019-08-14 21:36:19.010463      50.1.1.2 -> 50.1.1.1      ICMP 98 Echo (ping) request id=0x6a47, seq=512/2, ttl=255
2019-08-14 21:36:19.011376      50.1.1.2 -> 50.1.1.1      ICMP 98 Echo (ping) request id=0x6a47, seq=768/3, ttl=255
2019-08-14 21:36:19.012262      50.1.1.2 -> 50.1.1.1      ICMP 98 Echo (ping) request id=0x6a47, seq=1024/4, ttl=255
2019-08-14 21:36:19.013120      50.1.1.2 -> 50.1.1.1      ICMP 98 Echo (ping) request id=0x6a47, seq=1280/5, ttl=255
2019-08-14 21:36:19.014021      50.1.1.2 -> 50.1.1.1      ICMP 98 Echo (ping) request id=0x6a47, seq=1536/6, ttl=255
2019-08-14 21:36:19.014926      50.1.1.2 -> 50.1.1.1      ICMP 98 Echo (ping) request id=0x6a47, seq=1792/7, ttl=255
2019-08-14 21:36:19.015853      50.1.1.2 -> 50.1.1.1      ICMP 98 Echo (ping) request id=0x6a47, seq=2048/8, ttl=255
10 2019-08-14 21:36:19.016723      50.1.1.2 -> 50.1.1.1      ICMP 98 Echo (ping) request id=0x6a47, seq=2304/9, ttl=255

```

7. Filter using Destination ip 50.1.1.1.

```

DC1-N7K-1# ethanalyzer local interface inband capture-filter "dst 50.1.1.1"
Capturing on inband
2019-08-14 21:37:36.882361      50.1.1.2 -> 50.1.1.1      ICMP 98 Echo (ping) request id=0xc47, seq=0/0, ttl=255
2019-08-14 21:37:36.883476      50.1.1.2 -> 50.1.1.1      ICMP 98 Echo (ping) request id=0xc47, seq=256/1, ttl=255
2019-08-14 21:37:36.884469      50.1.1.2 -> 50.1.1.1      ICMP 98 Echo (ping) request id=0xc47, seq=512/2, ttl=255
2019-08-14 21:37:36.885476      50.1.1.2 -> 50.1.1.1      ICMP 98 Echo (ping) request id=0xc47, seq=768/3, ttl=255
2019-08-14 21:37:36.886386      50.1.1.2 -> 50.1.1.1      ICMP 98 Echo (ping) request id=0xc47, seq=1024/4, ttl=255
2019-08-14 21:37:36.887392      50.1.1.2 -> 50.1.1.1      ICMP 98 Echo (ping) request id=0xc47, seq=1280/5, ttl=255
2019-08-14 21:37:36.888408      50.1.1.2 -> 50.1.1.1      ICMP 98 Echo (ping) request id=0xc47, seq=1536/6, ttl=255
2019-08-14 21:37:36.889409      50.1.1.2 -> 50.1.1.1      ICMP 98 Echo (ping) request id=0xc47, seq=1792/7, ttl=255
2019-08-14 21:37:36.890328      50.1.1.2 -> 50.1.1.1      ICMP 98 Echo (ping) request id=0xc47, seq=2048/8, ttl=255
10 2019-08-14 21:37:36.891285      50.1.1.2 -> 50.1.1.1      ICMP 98 Echo (ping) request id=0xc47, seq=2304/9, ttl=255

```

8. Filter using port 1985

```
DC1-N7K-1# ethanalyzer local interface inband capture-filter "port 1985"
Capturing on inband
2019-08-14 21:41:17.659616      50.1.1.2 -> 50.1.1.1      TCP 74 21323 > hsrp [SYN] Seq=0
2 2019-08-14 21:41:17.660039      50.1.1.1 -> 50.1.1.2      TCP 60 hsrp > 21323 [RST, ACK]
2019-08-14 21:41:21.514749      50.1.1.2 -> 50.1.1.1      TCP 74 21386 > hsrp [SYN] Seq=0
4 2019-08-14 21:41:21.515156      50.1.1.1 -> 50.1.1.2      TCP 60 hsrp > 21386 [RST, ACK]
```

9. Filter using port range 20 till 23.

```
DC1-N7K-1# ethanalyzer local interface inband capture-filter "portrange 20-24"
Capturing on inband
2019-08-14 21:45:03.432647      50.1.1.2 -> 50.1.1.1      TCP 74 22132 > ftp-data
2 2019-08-14 21:45:03.432990      50.1.1.1 -> 50.1.1.2      TCP 60 ftp-data > 22132
2019-08-14 21:45:05.521557      50.1.1.2 -> 50.1.1.1      TCP 74 22161 > ftp [SYN] Seq=0
4 2019-08-14 21:45:05.521917      50.1.1.1 -> 50.1.1.2      TCP 60 ftp > 22161 [RST, ACK]
2019-08-14 21:45:07.384394      50.1.1.2 -> 50.1.1.1      TCP 74 22263 > ssh [SYN] Seq=0
2019-08-14 21:45:07.384948      50.1.1.1 -> 50.1.1.2      TCP 70 ssh > 22263 [SYN] Seq=0
2019-08-14 21:45:07.385512      50.1.1.2 -> 50.1.1.1      TCP 66 22263 > ssh [ACK] Seq=0
8 2019-08-14 21:45:07.542024      50.1.1.1 -> 50.1.1.2      SSH 92 Server Protocol
9 2019-08-14 21:45:07.654953      50.1.1.2 -> 50.1.1.1      TCP 66 22263 > ssh [ACK] Seq=0
10 2019-08-14 21:45:09.084835      50.1.1.2 -> 50.1.1.1      SSH 68 Encrypted request
```

```
DC1-N7K-1#
```

10. Filter using port tcp 443.

```
DC1-N7K-1# ethanalyzer local interface inband capture-filter "tcp port 443"
Capturing on inband
2019-08-14 21:47:18.815519      50.1.1.2 -> 50.1.1.1      TCP 74 22400 > https
2 2019-08-14 21:47:18.815943      50.1.1.1 -> 50.1.1.2      TCP 60 https > 22400
2019-08-14 21:47:22.204831      50.1.1.2 -> 50.1.1.1      TCP 74 22562 > https
4 2019-08-14 21:47:22.205222      50.1.1.1 -> 50.1.1.2      TCP 60 https > 22562
```

```
DC1-N7K-1#
```

11. Open the detail of any packet you captured.

```

DC1-N7K-1# ethanalyzer local interface inband capture-filter "tcp port 443" detail
Capturing on inband
Frame 1: 74 bytes on wire (592 bits), 74 bytes captured (592 bits) on interface 0
  Interface id: 0
  Encapsulation type: Ethernet (1)
  Arrival Time: Aug 14, 2019 21:52:06.240157000 UTC
  [Time shift for this packet: 0.000000000 seconds]
  Epoch Time: 1565819526.240157000 seconds
  [Time delta from previous captured frame: 0.000000000 seconds]
  [Time delta from previous displayed frame: 0.000000000 seconds]
  [Time since reference or first frame: 0.000000000 seconds]
  Frame Number: 1
  Frame Length: 74 bytes (592 bits)
  Capture Length: 74 bytes (592 bits)
  [Frame is marked: False]
  [Frame is ignored: False]
  [Protocols in frame: eth:ip:tcp]
Ethernet II, Src: Cisco_73:05:7c (00:de:fb:73:05:7c), Dst: 70:d3:79:63:6a:c2 (70:d3:79:63:6a:c2)
  Destination: 70:d3:79:63:6a:c2 (70:d3:79:63:6a:c2)
    Address: 70:d3:79:63:6a:c2 (70:d3:79:63:6a:c2)
      .... ..0. .... = LG bit: Globally unique address (factory de
      .... ..0 .... = IG bit: Individual address (unicast)
  Source: Cisco_73:05:7c (00:de:fb:73:05:7c)
    Address: Cisco_73:05:7c (00:de:fb:73:05:7c)
      .... ..0. .... = LG bit: Globally unique address (factory de
      .... ..0 .... = IG bit: Individual address (unicast)
  Type: IP (0x0800)
Internet Protocol Version 4, Src: 50.1.1.2 (50.1.1.2), Dst: 50.1.1.1 (50.1.1.1)
  Version: 4
  Header length: 20 bytes
  2   Differentiated Services Field: 0x00 (DSCP 0x00: Default; ECN: 0x00: Not-ECT (
      0000 00.. = Differentiated Services Codepoint: Default (0x00)
      .... ..00 = Explicit Congestion Notification: Not-ECT (Not ECN-Capable Tran
  Total Length: 60
  Identification: 0x2a20 (10784)
  Flags: 0x00
      0... .... = Reserved bit: Not set
      .0.. .... = Don't fragment: Not set
      ..0. .... = More fragments: Not set
  Fragment offset: 0
  Time to live: 64

```

12. How to save this file?

```

DC1-N7K-1# ethanalyzer local interface inband limit-captured-frames 2000 write bootflash:capture-ashish
Capturing on inband
2000
DC1-N7K-1# █

```

13. How to read this file?

```

DC1-N7K-1# dir bootflash: | include capture-ashish
 260296   Aug 14 22:01:34 2019  capture-ashish
DC1-N7K-1# █

```

```

DC1-N7K-1# ethanalyzer local read bootflash:capture-ashish
2019-08-14 22:00:55.047644000 CtrixsIn_02:00:00 -> PVST+          STP 64
2019-08-14 22:00:55.047775000 CtrixsIn_01:00:00 -> PVST+          STP 64
2019-08-14 22:00:55.047959000 00:f8:2c:90:ac:06 -> Spanning-tree-(for-
2019-08-14 22:00:55.150723000 Cisco_73:05:34 -> Spanning-tree-(for-bri
2019-08-14 22:00:55.150957000 Cisco_73:05:34 -> PVST+          STP 64 RS
2019-08-14 22:00:55.150972000 Cisco_73:05:34 -> PVST+          STP 64 RS
2019-08-14 22:00:56.047645000 CtrixsIn_02:00:00 -> PVST+          STP 64
2019-08-14 22:00:56.047812000 00:f8:2c:90:ac:04 -> Spanning-tree-(for-
2019-08-14 22:00:56.198405000 Cisco_73:04:73 -> Spanning-tree-(for-bri
2019-08-14 22:00:56.198610000 Cisco_73:04:73 -> PVST+          STP 64 RS
DC1-N7K-1# █

```

By default, it displays 10 packets

```

DC1-N7K-1# ethanalyzer local read bootflash:capture-ashish limit-captured-frames 16
2019-08-14 22:00:55.047644000 CtrixsIn_02:00:00 -> PVST+          STP 64 RST. Root = 8
2019-08-14 22:00:55.047775000 CtrixsIn_01:00:00 -> PVST+          STP 64 RST. Root = 8
2019-08-14 22:00:55.047959000 00:f8:2c:90:ac:06 -> Spanning-tree-(for-bridges)_00 ST
2019-08-14 22:00:55.150723000 Cisco_73:05:34 -> Spanning-tree-(for-bridges)_00 STP 6
2019-08-14 22:00:55.150957000 Cisco_73:05:34 -> PVST+          STP 64 RST. Root = 3276
2019-08-14 22:00:55.150972000 Cisco_73:05:34 -> PVST+          STP 64 RST. Root = 3276
2019-08-14 22:00:56.047645000 CtrixsIn_02:00:00 -> PVST+          STP 64 RST. Root = 3
2019-08-14 22:00:56.047812000 00:f8:2c:90:ac:04 -> Spanning-tree-(for-bridges)_00 ST
2019-08-14 22:00:56.198405000 Cisco_73:04:73 -> Spanning-tree-(for-bridges)_00 STP 6
2019-08-14 22:00:56.198610000 Cisco_73:04:73 -> PVST+          STP 64 RST. Root = 3276
2019-08-14 22:00:56.262644000 Cisco_73:05:34 -> LLDP_Multicast LLDP 349 Chassis Id =
2019-08-14 22:00:56.698360000 Cisco_73:04:73 -> PVST+          STP 64 RST. Root = 8192
2019-08-14 22:00:56.698592000 Cisco_73:04:79 -> Spanning-tree-(for-bridges)_00 STP 6
2019-08-14 22:00:57.047201000 CtrixsIn_02:00:00 -> PVST+          STP 64 RST. Root = 8
2019-08-14 22:00:57.047329000 CtrixsIn_01:00:00 -> PVST+          STP 64 RST. Root = 8
2019-08-14 22:00:57.047495000 00:f8:2c:90:ac:06 -> Spanning-tree-(for-bridges)_00 ST
DC1-N7K-1# █

```

In above, you can use the keyword detail to open the detail of the packet

14. Filter the ip. 50.1.1.2 from the capture file "capture-ashish"

```

DC1-N7K-1# ethanalyzer local read bootflash:capture-ashish display-filter "ip.src == 50.1.1.2"
2019-08-14 22:01:06.044222000 50.1.1.2 -> 50.1.1.1 TCP 74 22920 > https [SYN] Seq=0 Win=
2019-08-14 22:01:11.180378000 50.1.1.2 -> 50.1.1.1 TCP 74 23167 > telnet [SYN] Seq=0 Win
2019-08-14 22:01:15.111670000 50.1.1.2 -> 50.1.1.1 TCP 74 23201 > snmp [SYN] Seq=0 Win=1
2019-08-14 22:01:15.112776000 50.1.1.2 -> 50.1.1.1 TCP 66 23201 > snmp [ACK] Seq=1 Ack=1
2019-08-14 22:01:17.030046000 50.1.1.2 -> 50.1.1.1 TCP 71 [TCP segment of a reassembled
2019-08-14 22:01:17.031413000 50.1.1.2 -> 50.1.1.1 TCP 66 23201 > snmp [ACK] Seq=6 Ack=2
2019-08-14 22:01:17.031769000 50.1.1.2 -> 50.1.1.1 TCP 66 23201 > snmp [FIN, ACK] Seq=6 .
2019-08-14 22:01:27.895888000 50.1.1.2 -> 50.1.1.1 ICMP 98 Echo (ping) request id=0xfd4
2019-08-14 22:01:27.896977000 50.1.1.2 -> 50.1.1.1 ICMP 98 Echo (ping) request id=0xfd4
2019-08-14 22:01:27.897873000 50.1.1.2 -> 50.1.1.1 ICMP 98 Echo (ping) request id=0xfd4
DC1-N7K-1# █

```

15. Display the conversation between the source ip 50.1.1.1 and destination ip 50.1.1.2 from the capture file "capture-ashish".

```

DC1-N7K-1# ethanalyzer local read bootflash:capture-ashish display-filter "ip.src == 50.1.1.1 and ip.dst == 50.1.1.2"
2019-08-14 22:01:06.044578000 50.1.1.1 -> 50.1.1.2 TCP 60 https > 22920 [RST, ACK] Seq=1 Ack=1 Win=0 Len=0
2019-08-14 22:01:11.180705000 50.1.1.1 -> 50.1.1.2 TCP 60 telnet > 23167 [RST, ACK] Seq=1 Ack=1 Win=0 Len=0
2019-08-14 22:01:15.112214000 50.1.1.1 -> 50.1.1.2 TCP 70 snmp > 23201 [SYN, ACK] Seq=0 Ack=1 Win=16768 Len=0
2019-08-14 22:01:17.030925000 50.1.1.1 -> 50.1.1.2 TCP 66 snmp > 23201 [FIN, ACK] Seq=1 Ack=6 Win=17376 Len=0
2019-08-14 22:01:17.032028000 50.1.1.1 -> 50.1.1.2 TCP 66 snmp > 23201 [ACK] Seq=2 Ack=7 Win=17376 Len=0 TSval:
2019-08-14 22:01:27.896236000 50.1.1.1 -> 50.1.1.2 ICMP 98 Echo (ping) reply id=0xfd4d, seq=0/0, ttl=255 (re
2019-08-14 22:01:27.897234000 50.1.1.1 -> 50.1.1.2 ICMP 98 Echo (ping) reply id=0xfd4d, seq=256/1, ttl=255
2019-08-14 22:01:27.898122000 50.1.1.1 -> 50.1.1.2 ICMP 98 Echo (ping) reply id=0xfd4d, seq=512/2, ttl=255
2019-08-14 22:01:27.898977000 50.1.1.1 -> 50.1.1.2 ICMP 98 Echo (ping) reply id=0xfd4d, seq=768/3, ttl=255
2019-08-14 22:01:27.899863000 50.1.1.1 -> 50.1.1.2 ICMP 98 Echo (ping) reply id=0xfd4d, seq=1024/4, ttl=255
DC1-N7K-1# █

```

16. Display traffic from source 50.1.1.1 having tcp port 443 from the capture file "capture-ashish"

```

DC1-N7K-1# ethanalyzer local read bootflash:capture-ashish display-filter "ip.src == 50.1.1.1 and tcp.port eq 443"
2019-08-14 22:01:06.044578000 50.1.1.1 -> 50.1.1.2 TCP 60 https > 22920 [RST, ACK] Seq=1 Ack=1 Win=0 Len=0
DC1-N7K-1# █

```

17. Copy the file "capture-ashish" to tftp server 50.1.1.2.

```

DC1-N7K-1# copy bootflash:capture-ashish tftp:
Enter vrf (If no input, current vrf 'default' is considered):
Enter hostname for the tftp server: 50.1.1.2
Trying to connect to tftp server.....
Connection to Server Established.
DC1-N7K-1# █

```