



CCIE Data Center v3.0 Bootcamp

Classical Ethernet Switching on NX-OS

<https://t.me/learningnets>

In This Section

- + Classical Ethernet Design Overview
- + Implementing Classical Ethernet on NX-OS

Traditional Classical Ethernet Design

- + Three modular “building blocks”
 - + Access layer
 - + Aggregation / Distribution layer
 - + Core layer
- + [Enterprise Campus 3.0 Architecture: Overview and Framework](#)

Campus Network Example

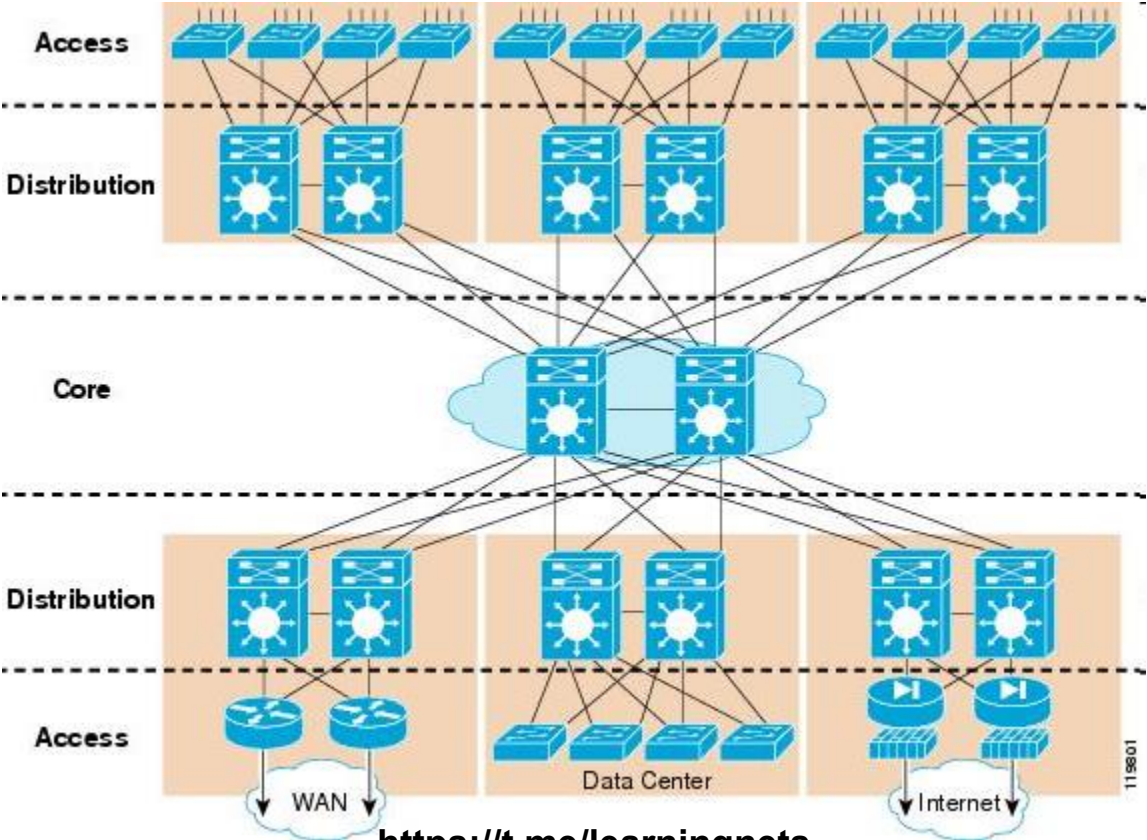

<https://t.me/learningnets>

Access Layer

- + Provides physical connectivity to end hosts
 - + PCs, phones, printers, WAPs, etc.
- + Typically no southbound redundancy
 - + E.g. end stations are single attached
 - + Result is a single point of failure

Access Layer (cont.)

- + Typically redundant northbound Layer 2 to distribution
 - + Spanning-Tree Protocol (STP) only allows for Active / Standby
 - + Includes all other STP variations
 - + PVST+, RSTP, MST, etc.
- + Link level redundancy can be achieved with Link Aggregation (LAG)
 - + E.g. EtherChannels, Port Channels, etc.
 - + Dual LAGs still means Active / Standby for STP
- + Crude load balancing with STP traffic engineering
 - + E.g. VLAN 10 uses uplink 1, VLAN 20 uses uplink 2

Access Layer (cont.)

- + Uplinks to distribution could be layer 3 routed
 - + [High Availability Campus Network Design— Routed Access Layer using EIGRP or OSPF](#)
 - + [High Availability Campus Network Design - Routed Access Layer using EIGRP or OSPF System Assurance Guide](#)
- + Limitation is the application
 - + Do we need direct layer 2 connectivity or not?
 - + E.g. vMotion

Aggregation / Distribution Layer

- + Aggregates physical connectivity to access layer switches
- + Adds link layer redundancy to both access and core layers
 - + STP for layer 2 redundancy to access
 - + ECMP (e.g. EIGRP/OSPF) for layer 3 redundancy to core
 - + Active / Active northbound but still Active / Standby southbound
- + Ideally adds node level redundancy
 - + Redundant modules, supervisors, PSUs, etc.
 - + Further potential for node redundancy via MLAGs
 - + E.g. VSS, StackWise

Aggregation / Distribution Layer (cont.)

- + Typically the layer 2 / layer 3 demarcation point
 - + Distribution switches are the default gateways for endpoints
 - + Terminates the layer 2 broadcast domains
 - + Is this a good thing?
- + Layer 2 redundancy with FHRPs
 - + HSRP, VRRP, & GLBP
 - + Generally only supports Active / Standby
- + Crude load balancing with FHRP split
 - + E.g. Agg1 HSRP active for VLAN10, Agg2 active for VLAN20

Core / Backbone Layer

- + Typically layer 3 only
 - + Goal is simply to route packets between distribution blocks
- + Same node and link level redundancy considerations
 - + ECMP for layer 3 load balancing and link level HA
 - + Redundant chassis, modules, supervisors, & PSUs for node HA

3 Tier Design Issues

- + Access layer is a single points of failure
 - + Typically for both links and nodes
- + Layer 2 multipath isn't supported
 - + Result is wasted links and link bandwidth
- + Scaling CE is a function of the MAC table
 - + All switches must learn all MACs
 - + Access layer switches typically have small TCAM
 - + I.e. Catalyst 2960 can hold only 8000 MAC addresses
- + Routed access layer breaks layer 2 adjacencies
 - + Are apps like vMotion a requirement?

Classical Ethernet on Nexus

- + Nexus at its core is a Layer 2 Switch
- + Similar in many aspects to Catalyst IOS
 - + VLANs, Trunking, VTP, Rapid PVST, MST, EtherChannel, PVLANS, UDLD, etc.
- + Key new features beyond Catalyst IOS
 - + FEX, vPC, FabricPath, VXLAN, OTV, etc.

Nexus NX-OS vs. Catalyst IOS

- + NX-OS has key Layer 2 behavioral differences vs. Catalyst IOS
 - + Default Port Modes
 - + STP Port Types
 - + STP Bridge Assurance
 - + Port Profiles

Default Port Modes

- + NX-OS default port modes can be changed as follows...
 - + **[no] system default switchport**
 - + Is the port routed or switched?
 - + **no system default switchport shutdown**
 - + Is the port up or down?
 - + Only applies if no other changes on the interface have been made

Spanning-Tree Port Types

- + NX-OS runs Rapid PVST by default
- + Layer 2 links have three STP port types
 - + **spanning-tree port-type normal**
 - + **spanning-tree port-type edge**
 - + **spanning-tree port-type network**
- + Normal ports act like Catalyst IOS ports
 - + Default STP port type
- + Edge ports are STP PortFast ports
- + Network ports run STP Bridge Assurance

STP Bridge Assurance

- + All STP Network Ports send BPDUs regardless of STP port state
 - + Legacy 802.1d only sends BPDUs from Root Bridge downstream
- + Primary goal is to protect against unidirectional links
 - + BPDUs become a bidirectional keepalive
 - + Replaces LoopGuard functionality
- + Secondary result is same functional effect as VTP Pruning
 - + VLANs stop forwarding on links that you do not receive BPDUs for that VLAN
- + Enabled globally by default
- + Enabled only on interfaces with **spanning-tree port type network**

Implementing CE on NX-OS

- + Classical Ethernet Workflow
 - + Create VLANs
 - + Create Trunks
 - + Optionally create Port-Channels
 - + Optionally modify STP modes & features

Creating VLANs Considerations

- + Nexus typically doesn't run VTP
 - + Implies all VLAN creations are locally significant
 - + You must create VLANs on all hops
 - + 7K, 5K, UCS, FabricPath Leaf & Spine, etc.
- + VLAN assignment doesn't imply creation
 - + NX-OS allows you assign a VLAN that doesn't exist
 - + Result is that port is inactive
 - + Catalyst IOS creates the VLAN when you assign it

Trunking Considerations

- + Nexus default switchport mode is access
 - + No DTP support like in Catalyst
 - + Implies **switchport mode trunk** is always required

STP Considerations

- + Nexus runs Rapid PVST by default
 - + Implies short pathcost
 - + Implies trunk allowed list is 1:1 with STP allowed list
- + Ports run STP Port Type Normal by default
 - + Implies no bridge assurance
 - + Implies convergence problems with UCS
- + Root Bridge placement
 - + Root recommended to be vPC Primary
 - + Root required to be FabricPath Leaf

Classical Ethernet Verifications

- + Common verifications
 - + **show interface status**
 - + **show interface brief**
 - + **show vlan [brief]**
 - + **show interface trunk**
 - + **show port-channel summary**
 - + **show spanning-tree [vlan|mst]**
 - + **show mac address-table**



<https://t.me/learningnets>