

# Service Manual

MF3220 Series  
**LaserBase MF3220**

**Canon**

## Application

This manual has been issued by Canon Inc. for qualified persons to learn technical theory, installation, maintenance, and repair of products. This manual covers all localities where the products are sold. For this reason, there may be information in this manual that does not apply to your locality.

## Corrections

This manual may contain technical inaccuracies or typographical errors due to improvements or changes in products. When changes occur in applicable products or in the contents of this manual, Canon will release technical information as the need arises. In the event of major changes in the contents of this manual over a long or short period, Canon will issue a new edition of this manual.

The following paragraph does not apply to any countries where such provisions are inconsistent with local law.

## Trademarks

The product names and company names used in this manual are the registered trademarks of the individual companies.

## Copyright

This manual is copyrighted with all rights reserved. Under the copyright laws, this manual may not be copied, reproduced or translated into another language, in whole or in part, without the written consent of Canon Inc.

***COPYRIGHT © 2001 CANON INC.***

*Printed in Japan*

## Caution









Use of this manual should be strictly supervised to avoid disclosure of confidential information.

---

# Symbols Used



---

This documentation uses the following symbols to indicate special information:

Symbol	Description
	Indicates an item of a non-specific nature, possibly classified as Note, Caution, or Warning.
	Indicates an item requiring care to avoid electric shocks.
	Indicates an item requiring care to avoid combustion (fire).
	Indicates an item prohibiting disassembly to avoid electric shocks or problems.
	Indicates an item requiring disconnection of the power plug from the electric outlet.
 Memo	Indicates an item intended to provide notes assisting the understanding of the topic in question.
 REF.	Indicates an item of reference assisting the understanding of the topic in question.
	Provides a description of a service mode.
	Provides a description of the nature of an error indication.

The following rules apply throughout this Service Manual:

1. Each chapter contains sections explaining the purpose of specific functions and the relationship between electrical and mechanical systems with reference to the timing of operation.

In the diagrams,  represents the path of mechanical drive; where a signal name accompanies the symbol, the arrow  indicates the direction of the electric signal.

The expression "turn on the power" means flipping on the power switch, closing the front door, and closing the delivery unit door, which results in supplying the machine with power.

2. In the digital circuits, '1' is used to indicate that the voltage level of a given signal is "High", while '0' is used to indicate "Low". (The voltage value, however, differs from circuit to circuit.) In addition, the asterisk (\*) as in "DRMD\*" indicates that the DRMD signal goes on when '0'.

In practically all cases, the internal mechanisms of a microprocessor cannot be checked in the field. Therefore, the operations of the microprocessors used in the machines are not discussed: they are explained in terms of from sensors to the input of the DC controller PCB and from the output of the DC controller PCB to the loads.

The descriptions in this Service Manual are subject to change without notice for product improvement or other purposes, and major changes will be communicated in the form of Service Information bulletins.

All service persons are expected to have a good understanding of the contents of this Service Manual and all relevant Service Information bulletins and be able to identify and isolate faults in the machine."

---

---

# Contents

## Chapter 1 PRODUCT DESCRIPTION

1.1 Product Specifications .....	1- 1
1.1.1 Product Specifications(EU/AE/CN/KOR).....	1- 1
1.2 Detailed Specifications .....	1- 1
1.2.1 Printing Speed .....	1- 1
1.2.2 Stack Upon Delivery .....	1- 2
1.2.3 System Requirements for Printer Driver .....	1- 2
1.3 Names of Parts .....	1- 2
1.3.1 External View.....	1- 2
1.3.2 Operation panel .....	1- 3
1.4 Safety .....	1- 4
1.4.1 Safety of Laser Light.....	1- 4
1.4.2 Regulations Under the Center for Devices and Radiological Health (CDRH) .....	1- 4
1.4.3 Handling the Laser Unit .....	1- 4
1.4.4 Safety of Toner .....	1- 4
1.4.5 Backup Battery .....	1- 5

## Chapter 2 TECHNICAL REFERENCE

2.1 Document Feed and Exposure System .....	2- 1
2.1.1 Overview/Configuration .....	2- 1
2.1.1.1 Overview .....	2- 1
2.2 Laser Exposure .....	2- 2
2.2.1 Overview/Configuration .....	2- 2
2.2.1.1 Overview .....	2- 2
2.3 Image Formation .....	2- 3
2.3.1 Overview/Configuration .....	2- 3
2.3.1.1 Overview .....	2- 3
2.4 Pickup and Feed System.....	2- 4
2.4.1 Overview/Configuration .....	2- 4
2.4.1.1 Overview .....	2- 4
2.4.2 Other Control .....	2- 4
2.4.2.1 Manual Pickup Control .....	2- 4
2.4.2.2 Cassette Pickup Control .....	2- 4
2.4.3 Detection Jams .....	2- 5
2.4.3.1 Jam Detection Outline.....	2- 5
2.4.3.2 Delay Jams .....	2- 5
2.4.3.3 Stationary Jams .....	2- 5
2.4.3.4 Other Jams .....	2- 5
2.5 Fixing Unit.....	2- 6
2.5.1 Overview/Configuration .....	2- 6
2.5.1.1 Overview .....	2- 6
2.5.2 Protection Function.....	2- 6
2.5.2.1 Protective Mechanisms .....	2- 6
2.5.2.2 Detecting a Fault in the Fixing Assembly.....	2- 6
2.6 External and Controls .....	2- 7
2.6.1 Power Supply .....	2- 7
2.6.1.1 Backup Battery.....	2- 7

## Chapter 3 DISASSEMBLY AND ASSEMBLY

3.1 EXTERNAL AND CONTROLS SYSTEM .....	3- 1
3.1.1 Front Cover .....	3- 1
3.1.1.1 Removing the Cassette.....	3- 1
3.1.1.2 Removing the front cover.....	3- 1
3.1.2 Rear Cover.....	3- 1
3.1.2.1 Removing the Cassette.....	3- 1
3.1.2.2 Removing the front cover.....	3- 1
3.1.2.3 Removing the right cover.....	3- 1
3.1.2.4 Removing the left cover.....	3- 1
3.1.2.5 Removing the rear cover.....	3- 1
3.1.3 Top Cover .....	3- 2
3.1.3.1 Removing the Cassette.....	3- 2
3.1.3.2 Removing the front cover.....	3- 2
3.1.3.3 Removing the right cover.....	3- 2
3.1.3.4 Removing the left cover.....	3- 2
3.1.3.5 Removing the rear cover.....	3- 2
3.1.3.6 Removing the Scanner Unit.....	3- 2
3.1.3.7 Removing the top cover.....	3- 3
3.1.4 Right Cover .....	3- 3
3.1.4.1 Removing the Cassette.....	3- 3
3.1.4.2 Removing the front cover.....	3- 3
3.1.4.3 Removing the right cover.....	3- 3
3.1.5 Left Cover .....	3- 3
3.1.5.1 Removing the Cassette.....	3- 3
3.1.5.2 Removing the left cover.....	3- 3
3.1.6 Operation Panel Unit.....	3- 4
3.1.6.1 Removing the Cassette.....	3- 4
3.1.6.2 Removing the front cover.....	3- 4
3.1.6.3 Removing the right cover.....	3- 4
3.1.6.4 Removing the left cover.....	3- 4
3.1.6.5 Removing the rear cover.....	3- 4
3.1.6.6 Removing the Scanner Unit.....	3- 5
3.1.6.7 Removing the Board Unit.....	3- 5
3.1.6.8 Removing the Operation Panel Unit.....	3- 5
3.1.7 SCNT Board.....	3- 6
3.1.7.1 Removing the Cassette.....	3- 6
3.1.7.2 Removing the front cover.....	3- 6
3.1.7.3 Removing the right cover.....	3- 6
3.1.7.4 Removing the left cover.....	3- 6
3.1.7.5 Removing the rear cover.....	3- 6
3.1.7.6 Removing the Scanner Unit.....	3- 6
3.1.7.7 Removing the SCNT Board.....	3- 7
3.1.8 ECNT Board.....	3- 7
3.1.8.1 Removing the Cassette.....	3- 7
3.1.8.2 Removing the front cover.....	3- 7
3.1.8.3 Removing the left cover.....	3- 7
3.1.8.4 Removing the ECNT Board.....	3- 7
3.1.9 Power Supply PCB .....	3- 8
3.1.9.1 Removing the Cassette.....	3- 8
3.1.9.2 Removing the front cover.....	3- 8
3.1.9.3 Removing the right cover.....	3- 8
3.1.9.4 Removing the left cover.....	3- 8
3.1.9.5 Removing the rear cover.....	3- 8
3.1.9.6 Removing the Power Supply Shield Plate.....	3- 8
3.1.9.7 Removing the Power Supply Assembly.....	3- 9
3.1.9.8 Removing the Power Supply Board.....	3- 9
3.1.10 High-voltage Power Supply PCB .....	3- 9
3.1.10.1 Removing the Cassette.....	3- 9
3.1.10.2 Removing the front cover.....	3- 9
3.1.10.3 Removing the right cover.....	3- 9

---

---

3.1.10.4 Removing the left cover .....	3- 10
3.1.10.5 Removing the rear cover .....	3- 10
3.1.10.6 Removing the Power Supply Shield Plate .....	3- 10
3.1.10.7 Removing the Power Supply Board .....	3- 10
3.1.10.8 Removing the High-Voltage Power Supply Board .....	3- 11
3.1.11 Top Sensor .....	3- 11
3.1.11.1 Removing the Cassette .....	3- 11
3.1.11.2 Removing the front cover .....	3- 11
3.1.11.3 Removing the right cover .....	3- 11
3.1.11.4 Removing the left cover .....	3- 11
3.1.11.5 Removing the rear cover .....	3- 12
3.1.11.6 Removing the Scanner Unit .....	3- 12
3.1.11.7 Removing the top cover .....	3- 12
3.1.11.8 Removing the Right Frame .....	3- 12
3.1.11.9 Removing the Plate .....	3- 12
3.1.11.10 Removing the Left Frame .....	3- 13
3.1.11.11 Removing the Power Supply Shield Plate .....	3- 13
3.1.11.12 Removing the Power Supply Assembly .....	3- 13
3.1.11.13 Removing the top sensor .....	3- 13
3.1.12 Paper Delivery Sensor .....	3- 14
3.1.12.1 Removing the Cassette .....	3- 14
3.1.12.2 Removing the front cover .....	3- 14
3.1.12.3 Removing the right cover .....	3- 14
3.1.12.4 Removing the left cover .....	3- 14
3.1.12.5 Removing the rear cover .....	3- 14
3.1.12.6 Removing the Power Supply Shield Plate .....	3- 14
3.1.12.7 Removing the Scanner Unit .....	3- 15
3.1.12.8 Removing the Plate .....	3- 15
3.1.12.9 Removing the Paper Delivery Sensor .....	3- 15
3.2 Document Feed/Exposure System .....	3- 15
3.2.1 Scanner Unit .....	3- 15
3.2.1.1 Removing the Cassette .....	3- 15
3.2.1.2 Removing the front cover .....	3- 15
3.2.1.3 Removing the right cover .....	3- 16
3.2.1.4 Removing the left cover .....	3- 16
3.2.1.5 Removing the rear cover .....	3- 16
3.2.1.6 Removing the Scanner Unit .....	3- 16
3.2.2 Scanner Cover Unit .....	3- 17
3.2.2.1 Removing the Cassette .....	3- 17
3.2.2.2 Removing the front cover .....	3- 17
3.2.2.3 Removing the right cover .....	3- 17
3.2.2.4 Removing the left cover .....	3- 17
3.2.2.5 Removing the rear cover .....	3- 17
3.2.2.6 Removing the Scanner Unit .....	3- 17
3.2.2.7 Removing the Operation Panel Unit .....	3- 18
3.2.2.8 Scanner cover unit .....	3- 18
3.2.3 Contact Sensor .....	3- 18
3.2.3.1 Removing the Cassette .....	3- 18
3.2.3.2 Removing the front cover .....	3- 18
3.2.3.3 Removing the right cover .....	3- 18
3.2.3.4 Removing the left cover .....	3- 19
3.2.3.5 Removing the rear cover .....	3- 19
3.2.3.6 Removing the Scanner Unit .....	3- 19
3.2.3.7 Removing the Operation Panel Unit .....	3- 19
3.2.3.8 Removing the Scanner Cover Unit .....	3- 20
3.2.3.9 Removing the Flatbed Motor Unit .....	3- 20
3.2.3.10 Removing the Contact Sensor .....	3- 20
3.2.4 Flatbed Motor Unit .....	3- 20
3.2.4.1 Removing the Cassette .....	3- 20
3.2.4.2 Removing the front cover .....	3- 20
3.2.4.3 Removing the right cover .....	3- 21

3.2.4.4 Removing the left cover .....	3- 21
3.2.4.5 Removing the rear cover.....	3- 21
3.2.4.6 Removing the Scanner Unit.....	3- 21
3.2.4.7 Removing the Operation Panel Unit .....	3- 22
3.2.4.8 Removing the Scanner Cover Unit .....	3- 22
3.2.4.9 Removing the Flatbed Motor Unit .....	3- 22
<b>3.3 LASER EXPOSURE SYSTEM .....</b>	<b>3- 22</b>
3.3.1 Laser/Scanner Unit .....	3- 22
3.3.1.1 Removing the Cassette.....	3- 22
3.3.1.2 Removing the front cover.....	3- 22
3.3.1.3 Removing the right cover.....	3- 23
3.3.1.4 Removing the left cover .....	3- 23
3.3.1.5 Removing the rear cover.....	3- 23
3.3.1.6 Removing the Scanner Unit.....	3- 23
3.3.1.7 Removing the top cover .....	3- 24
3.3.1.8 Removing the Laser/Scanner Unit.....	3- 24
<b>3.4 IMAGE FORMATION SYSTEM.....</b>	<b>3- 24</b>
3.4.1 Transfer Charging Roller.....	3- 24
3.4.1.1 Removing the Transfer Charging Roller .....	3- 24
<b>3.5 PICKUP AND FEEDING SYSTEM.....</b>	<b>3- 24</b>
3.5.1 Cassette Pickup Roller.....	3- 24
3.5.1.1 Removing the Cassette.....	3- 24
3.5.1.2 Removing the front cover.....	3- 24
3.5.1.3 Removing the right cover .....	3- 25
3.5.1.4 Removing the left cover .....	3- 25
3.5.1.5 Removing the rear cover.....	3- 25
3.5.1.6 Removing the Scanner Unit.....	3- 25
3.5.1.7 Removing the top cover .....	3- 25
3.5.1.8 Removing the Right Frame .....	3- 26
3.5.1.9 Removing the Plate.....	3- 26
3.5.1.10 Removing the Left Frame.....	3- 26
3.5.1.11 Removing the Power Supply Shield Plate.....	3- 26
3.5.1.12 Removing the Power Supply Assembly .....	3- 26
3.5.1.13 Removing the Gear Unit.....	3- 27
3.5.1.14 Removing the Tooth-Missing Gear .....	3- 27
3.5.2 Cassette Pickup Solenoid .....	3- 27
3.5.2.1 Removing the Cassette.....	3- 27
3.5.2.2 Removing the front cover.....	3- 27
3.5.2.3 Removing the right cover .....	3- 27
3.5.2.4 Removing the left cover .....	3- 28
3.5.2.5 Removing the rear cover.....	3- 28
3.5.2.6 Removing the Scanner Unit.....	3- 28
3.5.2.7 Removing the top cover .....	3- 28
3.5.2.8 Removing the Right Frame .....	3- 29
3.5.2.9 Removing the Plate.....	3- 29
3.5.2.10 Removing the Left Frame.....	3- 29
3.5.2.11 Removing the Power Supply Shield Plate.....	3- 29
3.5.2.12 Removing the Power Supply Assembly .....	3- 29
3.5.2.13 Removing the Cassette Pickup Solenoid .....	3- 30
3.5.3 Cassette Separation Pad .....	3- 30
3.5.3.1 Removing the Cassette.....	3- 30
3.5.3.2 Removing the Rear of the Cassette .....	3- 30
3.5.3.3 Removing the Cassette Separation Pad .....	3- 30
3.5.4 Paper Feed Roller.....	3- 30
3.5.4.1 Removing the Cassette.....	3- 30
3.5.4.2 Removing the front cover.....	3- 30
3.5.4.3 Removing the right cover .....	3- 30
3.5.4.4 Removing the left cover .....	3- 31
3.5.4.5 Removing the rear cover.....	3- 31
3.5.4.6 Removing the Scanner Unit.....	3- 31



---

---

3.5.4.7 Removing the top cover .....	3- 31
3.5.4.8 Removing the Right Frame .....	3- 31
3.5.4.9 Removing the Plate.....	3- 32
3.5.4.10 Removing the Left Frame.....	3- 32
3.5.4.11 Removing the Power Supply Shield Plate.....	3- 32
3.5.4.12 Removing the Power Supply Assembly .....	3- 32
3.5.4.13 Removing the Gear Unit.....	3- 33
3.5.4.14 Removing the Tooth-Missing Gear .....	3- 33
3.5.4.15 Removing the Manual Stay .....	3- 33
3.5.4.16 Removing the Paper Feed Guide.....	3- 33
3.5.4.17 Removing the Paper Feed Roller .....	3- 33
<b>3.5.5 Manual Pickup Solenoid .....</b>	<b>3- 34</b>
3.5.5.1 Removing the Cassette.....	3- 34
3.5.5.2 Removing the front cover.....	3- 34
3.5.5.3 Removing the right cover .....	3- 34
3.5.5.4 Removing the left cover .....	3- 34
3.5.5.5 Removing the rear cover.....	3- 34
3.5.5.6 Removing the Scanner Unit.....	3- 34
3.5.5.7 Removing the top cover .....	3- 35
3.5.5.8 Removing the Right Frame .....	3- 35
3.5.5.9 Removing the Plate.....	3- 35
3.5.5.10 Removing the Left Frame.....	3- 35
3.5.5.11 Removing the Power Supply Shield Plate.....	3- 35
3.5.5.12 Removing the Power Supply Assembly .....	3- 36
3.5.5.13 Removing the Manual Pickup Solenoid .....	3- 36
<b>3.5.6 Main Motor.....</b>	<b>3- 36</b>
3.5.6.1 Removing the Cassette.....	3- 36
3.5.6.2 Removing the front cover.....	3- 36
3.5.6.3 Removing the right cover .....	3- 36
3.5.6.4 Removing the left cover .....	3- 37
3.5.6.5 Removing the rear cover.....	3- 37
3.5.6.6 Removing the Scanner Unit.....	3- 37
3.5.6.7 Removing the top cover .....	3- 37
3.5.6.8 Removing the Right Frame .....	3- 38
3.5.6.9 Removing the Plate.....	3- 38
3.5.6.10 Removing the Left Frame.....	3- 38
3.5.6.11 Removing the Power Supply Shield Plate.....	3- 38
3.5.6.12 Removing the Power Supply Assembly .....	3- 38
3.5.6.13 Removing the Main Motor .....	3- 39
<b>3.5.7 Gear Unit .....</b>	<b>3- 39</b>
3.5.7.1 Removing the Cassette.....	3- 39
3.5.7.2 Removing the front cover.....	3- 39
3.5.7.3 Removing the right cover .....	3- 39
3.5.7.4 Removing the Gear Unit .....	3- 39
<b>3.6 FIXING SYSTEM .....</b>	<b>3- 40</b>
<b>3.6.1 Fixing Film Unit.....</b>	<b>3- 40</b>
3.6.1.1 Removing the Cassette.....	3- 40
3.6.1.2 Removing the front cover.....	3- 40
3.6.1.3 Removing the right cover .....	3- 40
3.6.1.4 Removing the left cover .....	3- 40
3.6.1.5 Removing the rear cover.....	3- 40
3.6.1.6 Removing the Scanner Unit.....	3- 40
3.6.1.7 Removing the top cover .....	3- 41
3.6.1.8 Removing the Right Frame .....	3- 41
3.6.1.9 Removing the Plate.....	3- 41
3.6.1.10 Removing the Left Frame.....	3- 41
3.6.1.11 Removing the Power Supply Shield Plate.....	3- 41
3.6.1.12 Removing the Fixing Film Unit .....	3- 42
<b>3.6.2 Fixing Pressure Roller .....</b>	<b>3- 42</b>
3.6.2.1 Removing the Cassette.....	3- 42
3.6.2.2 Removing the front cover.....	3- 42

3.6.2.3 Removing the right cover .....	3- 42
3.6.2.4 Removing the left cover .....	3- 43
3.6.2.5 Removing the rear cover.....	3- 43
3.6.2.6 Removing the Scanner Unit.....	3- 43
3.6.2.7 Removing the top cover.....	3- 43
3.6.2.8 Removing the Right Frame.....	3- 44
3.6.2.9 Removing the Plate.....	3- 44
3.6.2.10 Removing the Left Frame.....	3- 44
3.6.2.11 Removing the Power Supply Shield Plate.....	3- 44
3.6.2.12 Removing the Fixing Film Unit.....	3- 44
3.6.2.13 Removing the Fixing Pressure Roller.....	3- 45

Chapter 4 MAINTENANCE AND INSPECTION

4.1 Periodically Replaced Parts .....	4- 1
4.1.1 Periodic Replacement Parts .....	4- 1
4.2 Periodical Service.....	4- 1
4.2.1 Periodical Service .....	4- 1
4.3 Cleaning .....	4- 1
4.3.1 Items Requiring Cleaning.....	4- 1
4.3.2 Cleaning Method (external covers).....	4- 1
4.3.3 Cleaning Method (scanning unit).....	4- 2
4.3.4 Cleaning Method (printer unit) .....	4- 2
4.4 Lubrications .....	4- 3
4.4.1 Areas Requiring Application of Grease.....	4- 3
4.4.2 Delivery Idler Gear .....	4- 3
4.4.3 Wheel Shaft .....	4- 4
4.4.4 Fixing Drive Transmission Gear.....	4- 4
4.4.5 Large Gear.....	4- 4
4.4.6 Feed Gear.....	4- 5
4.4.7 Internal Gear.....	4- 5
4.4.8 Large Gear Deceleration Gear/Plate R.....	4- 5
4.4.9 Large Gear Bushing R .....	4- 6
4.4.10 Main Motor .....	4- 6
4.4.11 Drive Releasing Arm .....	4- 7
4.4.12 FU Delivery Roller .....	4- 7
4.4.13 Pickup Idler Gear .....	4- 8
4.4.14 Feed Deceleration Gear.....	4- 8
4.4.15 Fixing Deceleration Gear .....	4- 8
4.4.16 FD Delivery Roller.....	4- 9
4.4.17 Large Gear Bushing F.....	4- 9
4.4.18 Pressure roller.....	4- 9
4.4.19 Cassette Pickup Roller.....	4- 10
4.4.20 CIS Shaft.....	4- 10

Chapter 5 TROUBLESHOOTING

5.1 Measurement and Adjustment .....	5- 1
5.1.1 Basic Adjustments .....	5- 1
5.1.1.1 Items of Adjustment .....	5- 1
5.2 Service Tools.....	5- 1
5.2.1 Special Tools .....	5- 1
5.3 Error Code.....	5- 1
5.3.1 Outline.....	5- 1
5.3.1.1 Error Code Outline.....	5- 1
5.3.1.2 Error Code .....	5- 1
5.4 Service Mode .....	5- 3

5.4.1 Outline .....	5- 3
5.4.1.1 Service Data Setting .....	5- 3
5.4.1.2 Service Data Entry Method .....	5- 4
5.4.1.3 Service Data Flowchart .....	5- 4
5.4.2 Service Soft Switch Settings (SSSW).....	5- 4
5.4.2.1 Outline.....	5- 4
5.4.2.2 SSSW-SW02 .....	5- 5
5.4.2.3 SSSW-SW10 .....	5- 5
5.4.2.4 SSSW-SW16 .....	5- 5
5.4.2.5 SSSW-SW30 .....	5- 6
5.4.2.6 SSSW-SW33 .....	5- 6
5.4.2.7 SSSW-SW37 .....	5- 6
5.4.2.8 SSSW-SW51 .....	5- 7
5.4.2.9 SSSW-SW54 .....	5- 7
5.4.3 Report Output (REPORT).....	5- 7
5.4.3.1 SERVICE DATA LIST .....	5- 7
5.4.4 Test Mode (TEST) .....	5- 7
5.4.4.1 Faculty Test .....	5- 7

Chapter 6 APPENDIX

6.1 Outline of Electrical Components .....	6- 1
6.1.1 Sensor .....	6- 1
6.1.1.1 Arrangement of Sensors and Switches.....	6- 1
6.1.2 PCBs .....	6- 2
6.1.2.1 Arrangement of PCBs .....	6- 2

---

## Chapter 1 PRODUCT DESCRIPTION

---

---

---

# Contents

1.1 Product Specifications.....	1-1
1.1.1 Product Specifications(EU/AE/CN/KOR).....	1-1
1.2 Detailed Specifications .....	1-1
1.2.1 Printing Speed .....	1-1
1.2.2 Stack Upon Delivery.....	1-2
1.2.3 System Requirements for Printer Driver.....	1-2
1.3 Names of Parts .....	1-2
1.3.1 External View .....	1-2
1.3.2 Operation panel.....	1-3
1.4 Safety .....	1-4
1.4.1 Safety of Laser Light .....	1-4
1.4.2 Regulations Under the Center for Devices and Radiological Health (CDRH).....	1-4
1.4.3 Handling the Laser Unit.....	1-4
1.4.4 Safety of Toner .....	1-4
1.4.5 Backup Battery.....	1-5

## 1.1 Product Specifications

### 1.1.1 Product Specifications(EU/AE/CN/KOR)

<b>Body installation method</b>	Desktop
<b>Exposure Method</b>	Semi-conductor laser
<b>Development Method</b>	Toner projection
<b>Transfer Method</b>	Roller transfer
<b>Fixing method</b>	On-demand fixing
<b>Delivery method</b>	Facedown /Faceup
<b>Toner level detection function</b>	None
<b>Toner supply type</b>	Toner cartridge replacement / Cartridge
<b>Document type</b>	Sheet, 3D object (up to 2kg)
<b>Maximum document size</b>	216 x 297 mm
<b>Scanning method</b>	CIS scanning method
<b>Reproduction ratio</b>	50 to 200%
<b>Print area</b>	Print: 5 mm and more inner from paper edges/ Copy: 2 mm and more inner from paper edges
<b>Reading resolution</b>	600 x 600 dpi
<b>Copying resolution</b>	600 x 600 dpi
<b>Printing resolution</b>	600 x 600 dpi
<b>Print speed (A4)</b>	approx. 20 sheets/min
<b>Print speed(LTR)</b>	approx. 21 sheets/min
<b>Warm-up Time</b>	Approx. 8 sec. (temperature: 20 deg C, humidity: 65%; from when the machine is plugged in until the standby display appears) : Warm-up time may differ depending on the condition and environment of the machine.
<b>First Print Time</b>	approx. 11 sec.
<b>Cassette paper size</b>	A4, B5, A5, Letter, Legal, Executive, Envelope (DL, ISO-C5, COM10, MONARCH)
<b>Multi-purpose paper size</b>	A4, B5, A5, Letter, Legal, Executive, Envelope (DL, ISO-C5, COM10, MONARCH)
<b>Cassette paper type</b>	Plain paper (64 to 90g/m <sup>2</sup> ), Heavy paper (105 to 128g/m <sup>2</sup> ), Recycled paper (64 to 80g/m <sup>2</sup> ) Transparencyp, Envelope
<b>Multi-purpose paper type</b>	Plain paper (64 to 90g/m <sup>2</sup> ), Heavy paper (105 to 128g/m <sup>2</sup> ), Recycled paper (64 to 80g/m <sup>2</sup> ) Transparencyp, Envelope
<b>Cassette capacity</b>	Plain paper (64, 75, 80 g/m <sup>2</sup> ): approx. 250 sheets, Heavy paper (90, 105 g/m <sup>2</sup> ): approx. 200 sheets, Heavy paper H (128 g/m <sup>2</sup> ): approx. 100 sheets, Transparency: approx. 100 sheets, Label: approx. 100 sheets, Envelope: approx. 20 sheets
<b>Multi-purpose capacity</b>	1 sheet
<b>Continuous reproduction</b>	99 sheets
<b>Energy save mode</b>	None
<b>Operating environment (Temperature range)</b>	15 to 30 deg C
<b>Operating environment (Humidity range)</b>	10 to 80 %RH
<b>Power supply rating</b>	230V, 50-60Hz
<b>Power consumption (Maximum)</b>	approx. 780 W
<b>Dimensions</b>	449 mm x 539 mm x 369 mm
<b>Weight</b>	approx. 11 kg (including cartridge)
<b>Option</b>	None

## 1.2 Detailed Specifications

### 1.2.1 Printing Speed

T-1-1

Paper size	Fixing mode						
	Plain paper	Plain paper L	Heavy paper	Heavy paper H	Transparency	Envelope	COM10
A4 ( to 64 g/m <sup>2</sup> )	20	20	20	12	20	-	-
A4 (65 to 90 g/m <sup>2</sup> )	-	18	10	8	18	-	-
B5 (64 to 90 g/m <sup>2</sup> )	8	8	4	4	8	-	-
A5 (64 to 90 g/m <sup>2</sup> )	8	8	4	4	8	-	-
A4 (105 to 128 g/m <sup>2</sup> )	-	-	18	12	-	-	-
B5 (105 to 128 g/m <sup>2</sup> )	-	-	4	4	-	-	-
LTR (75 to 90 g/m <sup>2</sup> )	21	21	21	12	21	-	-

Paper size	Fixing mode						
	Plain paper	Plain paper L	Heavy paper	Heavy paper H	Transparency	Envelope	COM10
LGL (75 to 90 g/m <sup>2</sup> )	15	-	-	-	-	-	-
LTR (Bond 75 to 90 g/m <sup>2</sup> , 105 g/m <sup>2</sup> )	-	-	21	12	-	-	-
Envelope	-	-	-	-	-	-	4

(unit: sheets/min)

### 1.2.2 Stack Upon Delivery

T-1-2

Paper type	Face-down	Face-up
Plain paper (64 to 90 g/m <sup>2</sup> )	Approx. 60 sheets	1 sheet
Heavy paper (105 to 128 g/m <sup>2</sup> )	Approx. 30 sheets	1 sheet
Transparency	Approx. 10 sheets	1 sheet
Label	Approx. 10 sheets	1 sheet
Envelope	Approx. 10 sheets	1 sheet



The values herein are estimates only and are subject to change for product improvement.

### 1.2.3 System Requirements for Printer Driver

#### Operating System

Windows 98/98SE, Windows Me, Windows 2000 Professional, Windows XP

#### Computer

Any computer on which Windows 98, Windows Se, Windows Me, Windows 2000, or Windows XP runs properly.

#### Hardware Environment

- IBM or IBM-compatible PC
- CD-ROM drive or network environment with the access to CD-ROM
- PC equipped with a USB port and the USB class driver installed

T-1-3

OS	CPU	RAM	Available Free Disk Space
Windows 98	Intel Pentium 90 MHz or greater	32 MB of RAM, 64 MB or greater is recommended	At least 115 MB, 200MB or greater is recommended
Windows Me	Intel Pentium 150 MHz or greater	32 MB of RAM, 64 MB or greater is recommended	At least 115 MB, 200MB or greater is recommended
Windows 2000* Professional	Intel Pentium 133 MHz or greater, or compatible micro processors (up to 2 processors are supported)	64 MB of RAM, 128 MB or greater is recommended	At least 115 MB, 200MB or greater is recommended
Windows XP*	Pentium Family 300 MHz or greater	64 MB of RAM, 128 MB or greater is recommended	At least 115 MB, 200MB or greater is recommended

\*Log on as a user with administrator privileges is recommended.

## 1.3 Names of Parts

### 1.3.1 External View

<Front View>

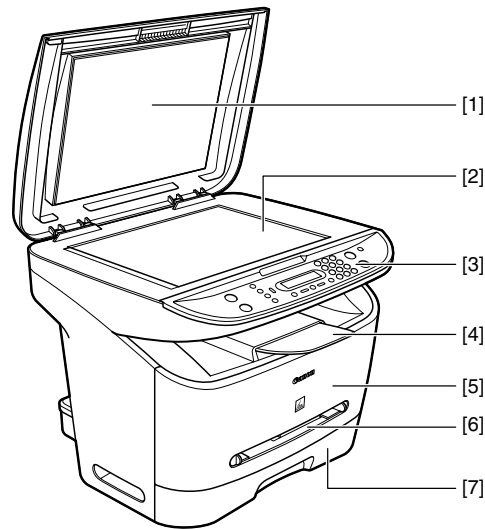

F-1-1  
T-1-4

- [1] Platen glass cover
- [2] Platen glass
- [3] Operation panel
- [4] Output tray
- [5] Front cover
- [6] Multi-purpose feeder
- [7] Cassette

<Rear View>

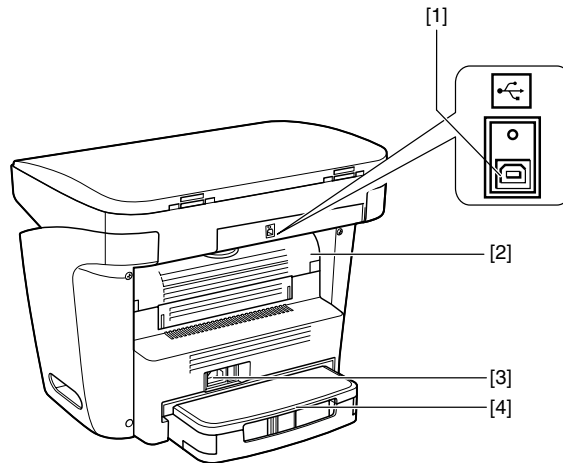

F-1-2  
T-1-5

- [1] USB port
- [2] Face up cover
- [3] Power socket
- [4] Extension cover

1.3.2 Operation panel

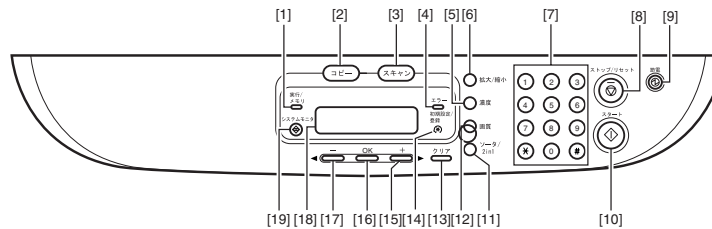

F-1-3  
T-1-6

- [1] Practice/Memory
- [2] COPY Key
- [11] Collate/2on1/ key
- [12] image Quality key



[3] SCAN Key	[13] Clear key
[4] Error indicator	[14] Initial setting/Registration
[5] Exposure key	[15] (+) key
[6] Enlarge/Reduce key	[16] OK key
[7] Numeric keys	[17] (-) key
[8] Stop/Reset key	[18] LCD
[9] Energy Saver key	[19] Status Monitor key
[10] Start key	

## 1.4 Safety

### 1.4.1 Safety of Laser Light

Laser radiation could be hazardous to the human body. For this reason, laser radiation emitted inside this machine is hermetically sealed within the protective housing and external cover. No radiation can leak from the machine in the normal operation of the product by the user.

### 1.4.2 Regulations Under the Center for Devices and Radiological Health (CDRH)

The CDRH of the US Food and Drug Administration put into effect regulations governing the sale of laser products in the US on August 2, 1976. These regulations apply to all laser products produced on and after August 1, 1976, and a laser product cannot be sold unless it has been certified to comply with the regulations. The following is the label used to indicate that the product has been certified under the regulations, and all laser products sold in the US must bear the label.

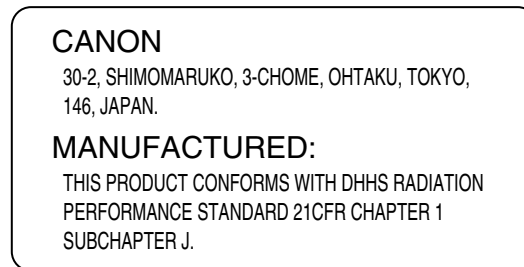

F-1-4

### 1.4.3 Handling the Laser Unit

The laser scanner unit emits invisible laser light inside it. If exposed to laser light, the human eye can irreparably be damaged. Never attempt to disassemble the laser scanner unit. (It is not designed for servicing in the field). The covers around the laser scanner unit are identified by the following label [1].

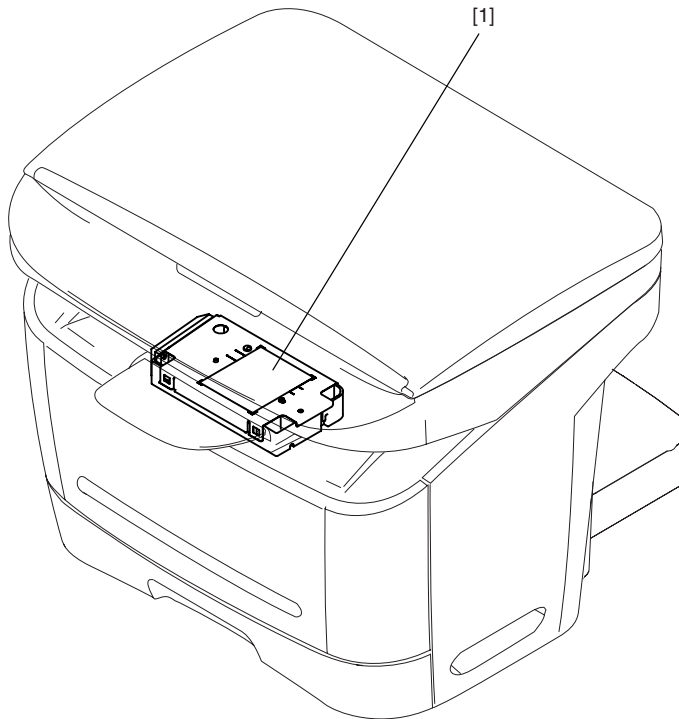

F-1-5

### 1.4.4 Safety of Toner

The machine's toner is a non-toxic material composed of plastic, iron, and small amounts of dye.



Do not put the toner into fire. It may explode.

Toner on the Skin or Clothes

1. If your skin or clothes came into contact with toner, wash with water at once.
2. Do not use warm or hot water, which will cause the toner to jell, permanently fusing it with the fibers of the clothes.
3. Do not bring toner into contact with vinyl material. They are likely to react with each other.

### 1.4.5 Backup Battery

The machine's SCNT PCB are equipped with a lithium battery (1 pc. each) serving as a backup source of power in the event of a power shortage or when the power plug is removed.

---



RIISK OF EXPLOSION IF BATTERY IS REPLACED BY AN INCORRECT TYPE.  
DISPOSE OF USED BATTERIES ACCORDING TO THE INSTRUCTIONS.

---

---

## Chapter 2 TECHNICAL REFERENCE

---

---

---

# Contents

2.1 Document Feed and Exposure System.....	2-1
2.1.1 Overview/Configuration .....	2-1
2.1.1.1 Overview .....	2-1
2.2 Laser Exposure.....	2-2
2.2.1 Overview/Configuration .....	2-2
2.2.1.1 Overview .....	2-2
2.3 Image Formation.....	2-3
2.3.1 Overview/Configuration .....	2-3
2.3.1.1 Overview .....	2-3
2.4 Pickup and Feed System .....	2-4
2.4.1 Overview/Configuration .....	2-4
2.4.1.1 Overview .....	2-4
2.4.2 Other Control .....	2-4
2.4.2.1 Manual Pickup Control .....	2-4
2.4.2.2 Cassette Pickup Control .....	2-4
2.4.3 Detection Jams .....	2-5
2.4.3.1 Jam Detection Outline.....	2-5
2.4.3.1.1 Type so Jams .....	2-5
2.4.3.2 Delay Jams .....	2-5
2.4.3.2.1 Pickup Delay Jam.....	2-5
2.4.3.2.2 Delivery Delay Jam.....	2-5
2.4.3.3 Stationary Jams .....	2-5
2.4.3.3.1 Pickup Stationary Jam.....	2-5
2.4.3.3.2 Delivery Stationary Jam.....	2-5
2.4.3.4 Other Jams.....	2-5
2.4.3.4.1 Wrap Jam.....	2-5
2.4.3.4.2 Initial Jam.....	2-5
2.4.3.4.3 Cover Open Jam.....	2-5
2.5 Fixing Unit.....	2-6
2.5.1 Overview/Configuration .....	2-6
2.5.1.1 Overview .....	2-6
2.5.2 Protection Function.....	2-6
2.5.2.1 Protective Mechanisms .....	2-6
2.5.2.2 Detecting a Fault in the Fixing Assembly.....	2-6
2.6 External and Controls.....	2-7
2.6.1 Power Supply .....	2-7
2.6.1.1 Backup Battery.....	2-7
2.6.1.1.1 Backup Battery.....	2-7

---

## 2.1 Document Feed and Exposure System

---

### 2.1.1 Overview/Configuration

#### 2.1.1.1 Overview

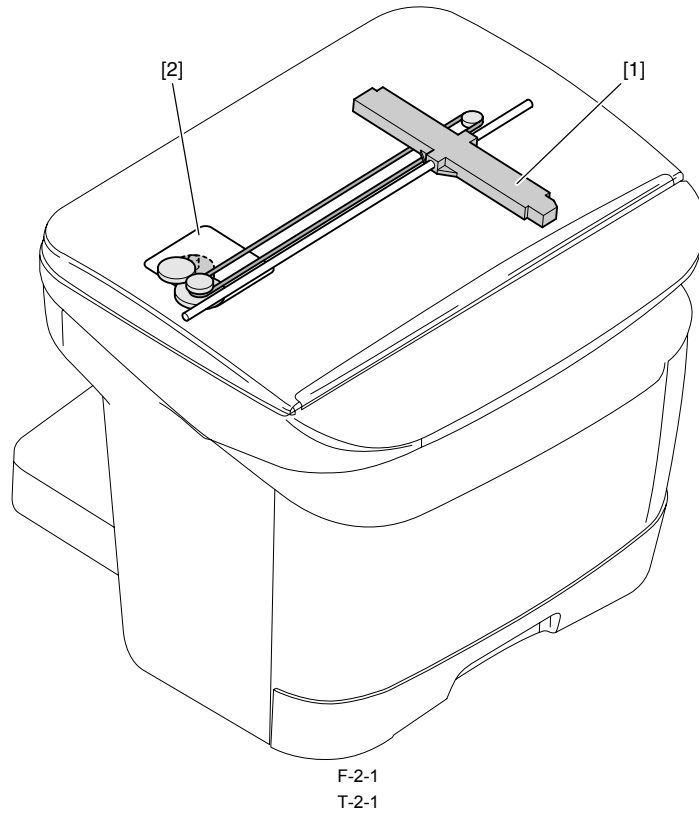

[1] CIS unit

[2] Flatbed motor

The CIS unit driven by the flatbed motor reads out image data of a document on the platen glass.

## 2.2 Laser Exposure

### 2.2.1 Overview/Configuration

#### 2.2.1.1 Overview

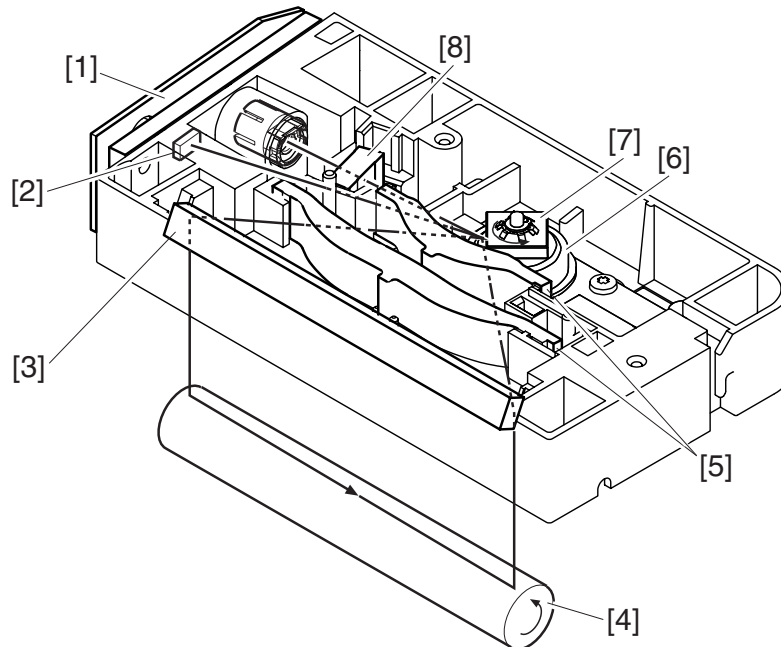

F-2-2  
T-2-2

- |                         |                      |
|-------------------------|----------------------|
| [1] Laser driver PCB    | [5] Imaging lens     |
| [2] BD sensor           | [6] Scanner motor    |
| [3] Reflecting mirror   | [7] 4-facet mirror   |
| [4] Photosensitive drum | [8] Cylindrical lens |

The machine's laser scanner assembly consists of the laser driver and the scanner motor, which are driven by signals coming from the engine controller. The laser driver serves to turn on the laser diode according to the laser control signal and video signals from the engine controller. The laser beam moves thorough the collimator less and the cylindrical lens to reach the 4-facet mirror rotating at a specific speed. The leaser beam reflected by the 4-facet mirror moves through the imaging lens arranged in front of the 4-facet mirror and the reflecting mirror to reach and focus on the photosensitive drum. When the 4-facet mirror rotates at a specific speed, the laser beam scans the photosensitive drum in keeping with the mirror rotation, thus drawing static images on the photosensitive drum.

#### MEMO:

##### **BD Fault**

The machine identifies a BD fault if it does not detect the /BDI signal within 0.1 sec after the scanner motor is forced to accelerate. It also detects a BD fault if it does not detect a specific interval of /BDI signals for 2 sec continuously after the scanner motor has reached a specific revolution (number of rotations).

##### **Scanner Fault**

If the machine does not detect the /BDI signal 1.4 sec after it has stopped forcing the scanner motor to accelerate, it extends the period of detection by 120 sec; if it still does not detect a specific interval of /BDI signals, it identifies a scanner fault.

##### **BD Error**

The machine identifies a BD error if it does not detect the /BDI signal at a specific interval while the /BDI signal is being generated. It, however, does not identify a BD error under the following condition:

- the door is identified as being open within 0.2 sec after detection of a BD error.
- a BD fault or a scanner fault is detected after a BD error has been identified.



The laser/scanner unit contains parts that cannot be adjusted in the field. Do not attempt to disassemble the laser/scanner unit.

## 2.3 Image Formation

### 2.3.1 Overview/Configuration

#### 2.3.1.1 Overview

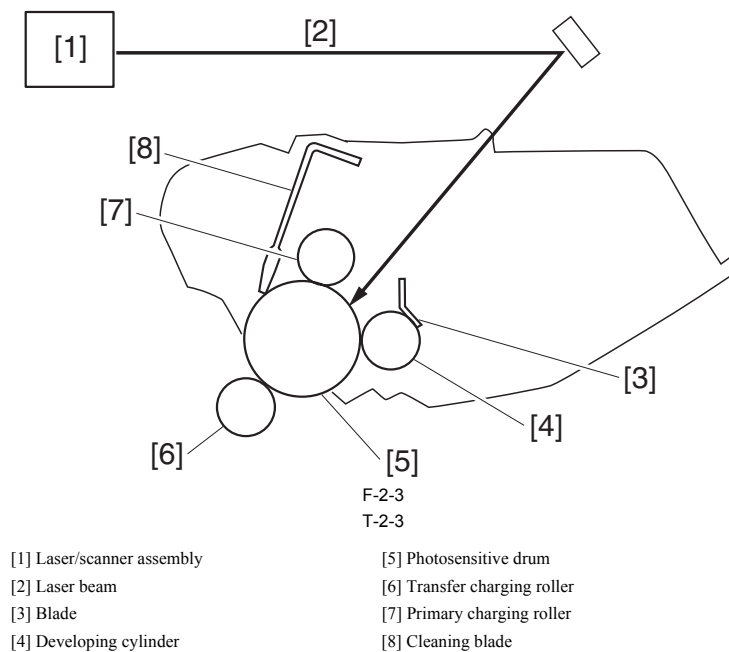

In response to a print command, the engine controller turns on the main motor to drive the photosensitive drum, developing cylinder, primary charging roller, and transfer charging roller.

Thereafter, the machine uses the primary charging roller to charge the surface of the photosensitive drum to an even, negative potential and, at the same time, directs the laser beam across the surface of the photosensitive drum. (The laser beam is modulated according to the incoming video signals.)

The image thus formed on the photosensitive drum is a static, latent image; it is turned into a visible image by means of the toner from the developing cylinder. The resulting toner image is then transferred to paper by the work of the transfer charging roller, and the paper is sent to the fixing assembly. The surface of the photosensitive drum is cleaned by the cleaning blade so that it is free of residual toner; after cleaning, the primary charging roller once again charges the surface to an even, negative potential to prepare for the formation of a new static, latent image.



#### Drum Cover Shutter

If the surface of the photosensitive drum is exposed to strong light, it develops what is known as "photo memory," which can cause white spots or black lines in images. To protect the drum against light, the machine is equipped with a drum cover shutter. The drum cover shutter must never be opened unless doing so proves to be absolutely necessary.

## 2.4 Pickup and Feed System

### 2.4.1 Overview/Configuration

#### 2.4.1.1 Overview

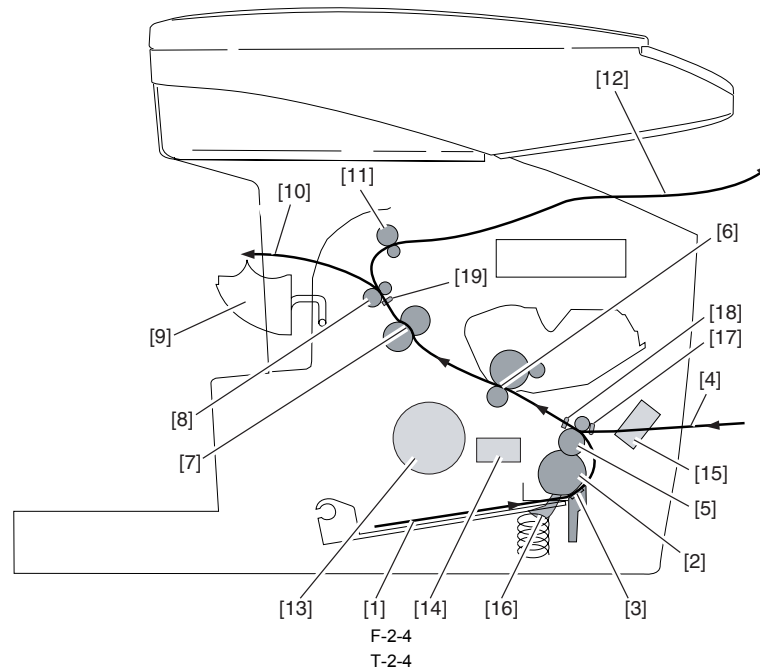

- |   |                                  |
|---|----------------------------------|
| [1] Cassette feed   | [12] Face-down delivery          |
| [2] Cassette pickup roller  | [13] Main motor                  |
| [3] Separation pad  | [14] Cassette pickup solenoid    |
| [4] Manual feed   | [15] Manual feed pickup solenoid |
| [5] Feed roller   | [16] Cassette paper sensor       |
| [6] Transfer assembly (photosensitive drum, transfer charging roller) | [17] Manual feed paper sensor    |
| [7] Fixing assembly (fixing film, fixing pressure roller)             | [18] Top sensor                  |
| [8] Delivery roller   | [19] Delivery sensor             |
| [9] Face-up cover   |                                  |
| [10] Face-up delivery   |                                  |
| [11] Face-down delivery roller  |                                  |

#### Pickup and Feed Operation (from the cassette)

If the cassette paper sensor detects the presence of paper while the absence of paper is identified in the manual feed pickup assembly, the machine picks up paper from the cassette.

When the main motor operates and the cassette pickup solenoid goes on, the cassette pickup roller makes a single rotation to pick up paper. The paper is then moved from the transfer assembly to the fixing assembly by the feed roller; it is ultimately delivered outside the machine by the work of the delivery roller.

When the face-up cover is open, the paper is delivered face-up at the rear of the machine. If the face-up cover is closed, on the other hand, the paper is moved along the feed guide of the cover, and is delivered face-down at the top of the machine by the work of the face-down delivery roller.

#### Pickup and Feed Operation (from the manual feed section)

When paper is inserted into the pickup assembly, the manual feed paper sensor detects the presence of paper, and the machine uses the feed roller to pick and hold the leading edge of the paper. When printing starts, the machine turns on the manual feed pickup solenoid to stop the rotation of the feed roller so that the paper will not move forward until the laser/scanner and the fixing unit become ready for operation. When the laser/scanner and the fixing unit become ready for operation, the machine turns off the manual feed pickup solenoid to rotate the feed roller, thus moving the paper forward; the operation thereafter is identical to the operation used for pickup from the cassette.

### 2.4.2 Other Control

#### 2.4.2.1 Manual Pickup Control

Upon detection of manually inserted paper, the machine drives the main motor for the specified time to feed the paper to the position where it is to be fed between the feed rollers. In addition, the machine turns on the feed roller (manual pickup) solenoid to stop rotating the feed rollers, thus preventing the manually inserted paper from being fed askew. With the paper pressed against the feed rollers, the machine drives the main motor and turns off the solenoid to feed the paper between the feed rollers.

#### 2.4.2.2 Cassette Pickup Control

With the main motor running, the machine turns on the paper pickup solenoid at the specified timing to rotate the pickup rollers. If paper exists over the top sensor at the start of timing retry, the machine stops cassette pickup control. If paper does not exist, the machine retries cassette pickup control.



## 2.4.3 Detection Jams

### 2.4.3.1 Jam Detection Outline

#### 2.4.3.1.1 Type so Jams

0012-0906

The machine identifies the following types of jams:

##### **Pickup Delay Jam**

The top sensor does not go on within a specific period of time after pickup starts.

##### **Pickup Stationary Jam**

The top sensor goes on, but does not go off within a specific period of time.

##### **Delivery Delay Jam**

The top sensor goes on, but the delivery sensor does not go on within a specific period of time.

##### **Wrap Jam**

The delivery sensor goes on, but it goes off before a specific period of time passes.

##### **Delivery Stationary Jam**

The delivery sensor goes on, but it does not go off within a specific period of time.

##### **Initial Jam**

The top sensor or the delivery sensor goes on while the main motor is starting to rotate.

##### **Cover Open Jam**

The machine identifies a condition in which the front cover is opened while it is moving paper.

### 2.4.3.2 Delay Jams

#### 2.4.3.2.1 Pickup Delay Jam

0012-0907

If the top sensor does not detect the leading edge of paper within 1.2 sec after the start of pickup operation, the machine initiates pickup operation once gain. The machine identifies a pickup delay jam if the top sensor does not detect the leading edge of paper within 1.2 sec after the 2nd pickup operation.

#### 2.4.3.2.2 Delivery Delay Jam

0012-0908

The machine identifies a delay jam if the delivery sensor does not detect the leading edge of paper within 1.615 sec after the top sensor has detected the leading edge of paper.

### 2.4.3.3 Stationary Jams

#### 2.4.3.3.1 Pickup Stationary Jam

0012-0909

The machine identifies a pickup stationary jam if the top sensor does not detect the absence of paper within 3.575 sec after the top sensor has detected the leading edge of paper.

#### 2.4.3.3.2 Delivery Stationary Jam

0012-0911

The machine moves to a delivery stationary jam sequence if it does not detect a wrap jam.

The machine identifies a delivery stationary jam if the delivery sensor does not detect the trailing edge of paper for 1.715 sec after the top sensor has detected the trailing edge of paper.

### 2.4.3.4 Other Jams

#### 2.4.3.4.1 Wrap Jam

0012-0912

The machine starts a wrap jam detection sequence in 0.1 sec if it does not detect a delivery delay jam.

It identifies a wrap jam if the delivery sensor detects the trailing edge of paper within 1.06 sec after the top sensor has detected the trailing edge of paper.

The term "wrap jam" refers to paper that wraps around the fixing pressure roller; its leading edge passes through the delivery sensor, but it jams thereafter. The machine is designed to identify such a jam so as to prevent wrapping paper from fully moving into the fixing assembly.

#### 2.4.3.4.2 Initial Jam

0012-0913

The machine identifies an initial jam if the top sensor or the delivery sensor detects the presence of paper when the main motor starts to rotate.

#### 2.4.3.4.3 Cover Open Jam

0012-0914

The machine identifies a cover open jam if it detects that the front cover is open with the top sensor or the delivery sensor detecting the presence of paper (while paper is being moved or the machine is not running a jam check).

## 2.5 Fixing Unit

### 2.5.1 Overview/Configuration

#### 2.5.1.1 Overview

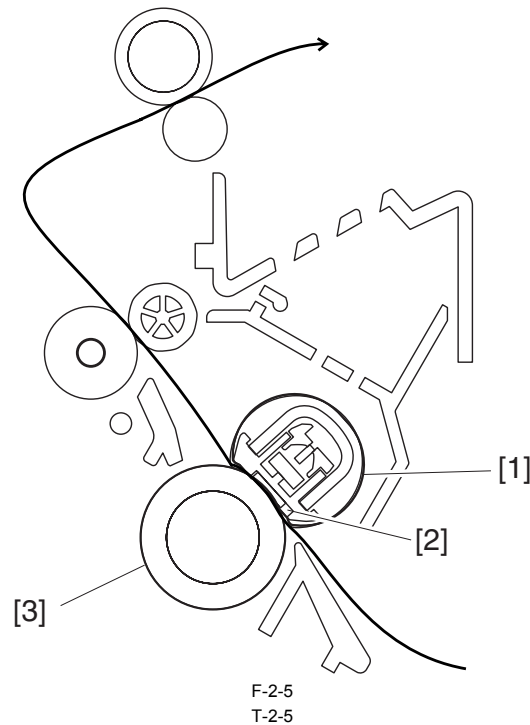

- [1] Fixing film unit
- [2] Fixing heater
- [3] Pressure roller

The machine's fixing system is an on-demand type, and its fixing assembly consists of the fixing film unit and the pressure roller: the fixing film has a built-in fixing heater, thermistor, and thermal fuse. The toner transferred to paper is heated by the fixing heater, which provides heat through the fixing film; the toner is forced under the pressure roller so that it is fused into the fibers of the paper under both heat and pressure.

### 2.5.2 Protection Function

#### 2.5.2.1 Protective Mechanisms

The machine is equipped with the following 3 types of protective mechanisms used to prevent its fixing heater from going awry.

1. protective mechanism by the CPU
2. protective mechanism by the fixing heater safety circuit
3. protective mechanism by the thermal fuse

##### 1. Protective Mechanism by the CPU

The machine's CPU monitors the voltage of the fixing heater temperature detection signal from the main thermistor and the sub thermistor at all times, and it cuts the power to the fixing heater if it finds that the fixing temperature appreciably exceeds a specific level.

When the fixing temperature abnormally increases and the voltage of the fixing heater temperature detection signal from the main thermistor drops to about 0.775 V (equivalent of 235 deg C) or less, the CPU causes the fixing heater drive signal to go Low and turns off the photo triac coupler, thus cutting power to the fixing heater.

If the temperature of the fixing heater abnormally increases and the voltage of the fixing heater temperature detection signal from the sub thermistor reaches about 2.779 V (equivalent of 320 deg C) or more, the CPU causes the fixing heater drive signal to go Low and turns off the photo triac couple, thus cutting off the power to the fixing heater.

##### 2. Protective Mechanism by the Fixing Heater Safety Circuit

The fixing heater safety circuit monitors the voltage of the fixing heater temperature detection signal from the main thermistor and the sub thermistor at all times.

If the fixing temperature appreciably exceeds a specific level, the machine cuts off the power to the fixing heater regardless of the instructions from the CPU.

When the temperature of the fixing heater increases abnormally and the voltage of the fixing heater temperature detection signal of the main thermistor reaches about 0.775 V (equivalent of 235 deg C) or less, the output of the comparator turns Low to turn off the relay, thus cutting off the power to the fixing heater.

Likewise, if the temperature of the fixing heater increases abnormally and the voltage of the fixing heater temperature detection signal of the sub thermistor reaches about 2.779 V (equivalent of 320 deg C) or more, the output of the comparator turns Low to turn off the transistor, thus turning off the relay and cutting off the power to the fixing heater regardless of the relay drive signal from the CPU.

##### 3. Protective Mechanism by the Thermal Fuse

If the temperature of the fixing heater increases abnormally and the temperature of the thermal fuse exceeds about 228 deg C, the thermal fuse starts to melt to cut off the power to the fixing heater.

#### 2.5.2.2 Detecting a Fault in the Fixing Assembly

The CPU identifies a fault in the fixing assembly for the following conditions (a. thorough g.) and operates as described:

1. the CPU causes the fixing heater drive signal to go Low to cut off the power to the fixing heater.
2. the CPU causes the relay drive signal to go Low to turn off the relay.
3. the CPU, if it detects a fault while printing is under way, discharges the paper being picked up or moved at the time, and immediately turns off the main motor,

- scanner motor, and high-voltage system and puts the printer unit in an error state.
- a) the reading of the main thermistor does not exceed 50 deg C within 2.34 sec after the start-up temperature control mechanism is started.
  - b) the CPU detects that the reading of the main thermistor remains 235 deg C or more for 1 sec continuously while fixing temperature control is under way.
  - c) the CPU detects that the reading of the main thermistor remains 100 deg C or less for 1.2 sec continuously while paper passage temperature control is under way; or the CPU detects that the reading of the main thermistor remains 50 deg C or less for 0.3 sec continuously while between-sheets temperature control is under way.
  - d) the CPU detects that the reading of the main thermistor remains less than 20 deg C for 0.3 sec continuously while fixing heater temperature control is under way.
  - e) the temperature of the main thermistor does not exceed 100 deg C within 20 sec after the start of start-up temperature control.
  - f) the CPU detects that the reading of the sub thermistor remains less than 35 deg C for 0.15 sec continuously while fixing heater temperature control is under way.
  - g) the CPU detects that the reading of the sub thermistor remains 320 deg C for 0.15 sec continuously while fixing heater temperature control is under way.

## 2.6 External and Controls

### 2.6.1 Power Supply

#### 2.6.1.1 Backup Battery

##### 2.6.1.1.1 Backup Battery

0012-3264

The machine's SCNT PCB are equipped with a lithium battery (1 pc. each) serving as a backup source of power in the event of a power shortage or when the power plug is removed.

	T-2-6	
SCNT PCB		litium battery (3V,220mAh)
Life		5yr or more (with power plug removed)
Replacement		not possible in the field on its own.



LIK OF EXPLOSION IF BATTERY IS REPLACED BY AN INCORRECT TYPE.  
DISPOSE OF USED BATTERIES ACCORDING TO THE INSTRUCTIONS.



---

## Chapter 3 DISASSEMBLY AND ASSEMBLY

---



---

---

# Contents

3.1 EXTERNAL AND CONTROLS SYSTEM .....	3-1
3.1.1 Front Cover .....	3-1
3.1.1.1 Removing the Cassette .....	3-1
3.1.1.2 Removing the front cover .....	3-1
3.1.2 Rear Cover .....	3-1
3.1.2.1 Removing the Cassette .....	3-1
3.1.2.2 Removing the front cover .....	3-1
3.1.2.3 Removing the right cover .....	3-1
3.1.2.4 Removing the left cover .....	3-1
3.1.2.5 Removing the rear cover .....	3-1
3.1.3 Top Cover .....	3-2
3.1.3.1 Removing the Cassette .....	3-2
3.1.3.2 Removing the front cover .....	3-2
3.1.3.3 Removing the right cover .....	3-2
3.1.3.4 Removing the left cover .....	3-2
3.1.3.5 Removing the rear cover .....	3-2
3.1.3.6 Removing the Scanner Unit .....	3-2
3.1.3.7 Removing the top cover .....	3-3
3.1.4 Right Cover .....	3-3
3.1.4.1 Removing the Cassette .....	3-3
3.1.4.2 Removing the front cover .....	3-3
3.1.4.3 Removing the right cover .....	3-3
3.1.5 Left Cover .....	3-3
3.1.5.1 Removing the Cassette .....	3-3
3.1.5.2 Removing the left cover .....	3-3
3.1.6 Operation Panel Unit .....	3-4
3.1.6.1 Removing the Cassette .....	3-4
3.1.6.2 Removing the front cover .....	3-4
3.1.6.3 Removing the right cover .....	3-4
3.1.6.4 Removing the left cover .....	3-4
3.1.6.5 Removing the rear cover .....	3-4
3.1.6.6 Removing the Scanner Unit .....	3-5
3.1.6.7 Removing the Board Unit .....	3-5
3.1.6.8 Removing the Operation Panel Unit .....	3-5
3.1.7 SCNT Board .....	3-6
3.1.7.1 Removing the Cassette .....	3-6
3.1.7.2 Removing the front cover .....	3-6
3.1.7.3 Removing the right cover .....	3-6
3.1.7.4 Removing the left cover .....	3-6
3.1.7.5 Removing the rear cover .....	3-6
3.1.7.6 Removing the Scanner Unit .....	3-6
3.1.7.7 Removing the SCNT Board .....	3-7
3.1.8 ECNT Board .....	3-7
3.1.8.1 Removing the Cassette .....	3-7
3.1.8.2 Removing the front cover .....	3-7
3.1.8.3 Removing the left cover .....	3-7
3.1.8.4 Removing the ECNT Board .....	3-7
3.1.9 Power Supply PCB .....	3-8
3.1.9.1 Removing the Cassette .....	3-8
3.1.9.2 Removing the front cover .....	3-8
3.1.9.3 Removing the right cover .....	3-8
3.1.9.4 Removing the left cover .....	3-8
3.1.9.5 Removing the rear cover .....	3-8
3.1.9.6 Removing the Power Supply Shield Plate .....	3-8

3.1.9.7 Removing the Power Supply Assembly .....	3-9
3.1.9.8 Removing the Power Supply Board.....	3-9
3.1.10 High-voltage Power Supply PCB .....	3-9
3.1.10.1 Removing the Cassette.....	3-9
3.1.10.2 Removing the front cover .....	3-9
3.1.10.3 Removing the right cover .....	3-9
3.1.10.4 Removing the left cover.....	3-10
3.1.10.5 Removing the rear cover.....	3-10
3.1.10.6 Removing the Power Supply Shield Plate .....	3-10
3.1.10.7 Removing the Power Supply Board.....	3-10
3.1.10.8 Removing the High-Voltage Power Supply Board.....	3-11
3.1.11 Top Sensor .....	3-11
3.1.11.1 Removing the Cassette.....	3-11
3.1.11.2 Removing the front cover .....	3-11
3.1.11.3 Removing the right cover .....	3-11
3.1.11.4 Removing the left cover.....	3-11
3.1.11.5 Removing the rear cover.....	3-12
3.1.11.6 Removing the Scanner Unit.....	3-12
3.1.11.7 Removing the top cover .....	3-12
3.1.11.8 Removing the Right Frame.....	3-12
3.1.11.9 Removing the Plate .....	3-12
3.1.11.10 Removing the Left Frame .....	3-13
3.1.11.11 Removing the Power Supply Shield Plate.....	3-13
3.1.11.12 Removing the Power Supply Assembly .....	3-13
3.1.11.13 Removing the top sensor.....	3-13
3.1.12 Paper Delivery Sensor.....	3-14
3.1.12.1 Removing the Cassette.....	3-14
3.1.12.2 Removing the front cover .....	3-14
3.1.12.3 Removing the right cover .....	3-14
3.1.12.4 Removing the left cover.....	3-14
3.1.12.5 Removing the rear cover.....	3-14
3.1.12.6 Removing the Power Supply Shield Plate.....	3-14
3.1.12.7 Removing the Scanner Unit.....	3-15
3.1.12.8 Removing the Plate .....	3-15
3.1.12.9 Removing the Paper Delivery Sensor.....	3-15
3.2 Document Feed/Exposure System.....	3-15
3.2.1 Scanner Unit.....	3-15
3.2.1.1 Removing the Cassette.....	3-15
3.2.1.2 Removing the front cover .....	3-15
3.2.1.3 Removing the right cover .....	3-16
3.2.1.4 Removing the left cover.....	3-16
3.2.1.5 Removing the rear cover.....	3-16
3.2.1.6 Removing the Scanner Unit.....	3-16
3.2.2 Scanner Cover Unit.....	3-17
3.2.2.1 Removing the Cassette.....	3-17
3.2.2.2 Removing the front cover .....	3-17
3.2.2.3 Removing the right cover .....	3-17
3.2.2.4 Removing the left cover.....	3-17
3.2.2.5 Removing the rear cover.....	3-17
3.2.2.6 Removing the Scanner Unit.....	3-17
3.2.2.7 Removing the Operation Panel Unit.....	3-18
3.2.2.8 Scanner cover unit .....	3-18
3.2.3 Contact Sensor .....	3-18
3.2.3.1 Removing the Cassette.....	3-18
3.2.3.2 Removing the front cover .....	3-18
3.2.3.3 Removing the right cover .....	3-18
3.2.3.4 Removing the left cover.....	3-19
3.2.3.5 Removing the rear cover.....	3-19
3.2.3.6 Removing the Scanner Unit.....	3-19
3.2.3.7 Removing the Operation Panel Unit.....	3-19
3.2.3.8 Removing the Scanner Cover Unit.....	3-20



---

---

3.2.3.9 Removing the Flatbed Motor Unit .....	3-20
3.2.3.10 Removing the Contact Sensor .....	3-20
3.2.4 Flatbed Motor Unit .....	3-20
3.2.4.1 Removing the Cassette .....	3-20
3.2.4.2 Removing the front cover .....	3-20
3.2.4.3 Removing the right cover .....	3-21
3.2.4.4 Removing the left cover .....	3-21
3.2.4.5 Removing the rear cover .....	3-21
3.2.4.6 Removing the Scanner Unit .....	3-21
3.2.4.7 Removing the Operation Panel Unit .....	3-22
3.2.4.8 Removing the Scanner Cover Unit .....	3-22
3.2.4.9 Removing the Flatbed Motor Unit .....	3-22
3.3 LASER EXPOSURE SYSTEM .....	3-22
3.3.1 Laser/Scanner Unit .....	3-22
3.3.1.1 Removing the Cassette .....	3-22
3.3.1.2 Removing the front cover .....	3-22
3.3.1.3 Removing the right cover .....	3-23
3.3.1.4 Removing the left cover .....	3-23
3.3.1.5 Removing the rear cover .....	3-23
3.3.1.6 Removing the Scanner Unit .....	3-23
3.3.1.7 Removing the top cover .....	3-24
3.3.1.8 Removing the Laser/Scanner Unit .....	3-24
3.4 IMAGE FORMATION SYSTEM .....	3-24
3.4.1 Transfer Charging Roller .....	3-24
3.4.1.1 Removing the Transfer Charging Roller .....	3-24
3.5 PICKUP AND FEEDING SYSTEM .....	3-24
3.5.1 Cassette Pickup Roller .....	3-24
3.5.1.1 Removing the Cassette .....	3-24
3.5.1.2 Removing the front cover .....	3-24
3.5.1.3 Removing the right cover .....	3-25
3.5.1.4 Removing the left cover .....	3-25
3.5.1.5 Removing the rear cover .....	3-25
3.5.1.6 Removing the Scanner Unit .....	3-25
3.5.1.7 Removing the top cover .....	3-25
3.5.1.8 Removing the Right Frame .....	3-26
3.5.1.9 Removing the Plate .....	3-26
3.5.1.10 Removing the Left Frame .....	3-26
3.5.1.11 Removing the Power Supply Shield Plate .....	3-26
3.5.1.12 Removing the Power Supply Assembly .....	3-26
3.5.1.13 Removing the Gear Unit .....	3-27
3.5.1.14 Removing the Tooth-Missing Gear .....	3-27
3.5.2 Cassette Pickup Solenoid .....	3-27
3.5.2.1 Removing the Cassette .....	3-27
3.5.2.2 Removing the front cover .....	3-27
3.5.2.3 Removing the right cover .....	3-27
3.5.2.4 Removing the left cover .....	3-28
3.5.2.5 Removing the rear cover .....	3-28
3.5.2.6 Removing the Scanner Unit .....	3-28
3.5.2.7 Removing the top cover .....	3-28
3.5.2.8 Removing the Right Frame .....	3-29
3.5.2.9 Removing the Plate .....	3-29
3.5.2.10 Removing the Left Frame .....	3-29
3.5.2.11 Removing the Power Supply Shield Plate .....	3-29
3.5.2.12 Removing the Power Supply Assembly .....	3-29
3.5.2.13 Removing the Cassette Pickup Solenoid .....	3-30
3.5.3 Cassette Separation Pad .....	3-30
3.5.3.1 Removing the Cassette .....	3-30
3.5.3.2 Removing the Rear of the Cassette .....	3-30
3.5.3.3 Removing the Cassette Separation Pad .....	3-30
3.5.4 Paper Feed Roller .....	3-30

3.5.4.1 Removing the Cassette.....	3-30
3.5.4.2 Removing the front cover .....	3-30
3.5.4.3 Removing the right cover .....	3-30
3.5.4.4 Removing the left cover.....	3-31
3.5.4.5 Removing the rear cover.....	3-31
3.5.4.6 Removing the Scanner Unit.....	3-31
3.5.4.7 Removing the top cover.....	3-31
3.5.4.8 Removing the Right Frame.....	3-31
3.5.4.9 Removing the Plate.....	3-32
3.5.4.10 Removing the Left Frame .....	3-32
3.5.4.11 Removing the Power Supply Shield Plate.....	3-32
3.5.4.12 Removing the Power Supply Assembly .....	3-32
3.5.4.13 Removing the Gear Unit.....	3-33
3.5.4.14 Removing the Tooth-Missing Gear .....	3-33
3.5.4.15 Removing the Manual Stay.....	3-33
3.5.4.16 Removing the Paper Feed Guide .....	3-33
3.5.4.17 Removing the Paper Feed Roller.....	3-33
<b>3.5.5 Manual Pickup Solenoid.....</b>	<b>3-34</b>
3.5.5.1 Removing the Cassette.....	3-34
3.5.5.2 Removing the front cover .....	3-34
3.5.5.3 Removing the right cover .....	3-34
3.5.5.4 Removing the left cover.....	3-34
3.5.5.5 Removing the rear cover.....	3-34
3.5.5.6 Removing the Scanner Unit.....	3-34
3.5.5.7 Removing the top cover.....	3-35
3.5.5.8 Removing the Right Frame.....	3-35
3.5.5.9 Removing the Plate.....	3-35
3.5.5.10 Removing the Left Frame .....	3-35
3.5.5.11 Removing the Power Supply Shield Plate.....	3-35
3.5.5.12 Removing the Power Supply Assembly .....	3-36
3.5.5.13 Removing the Manual Pickup Solenoid .....	3-36
<b>3.5.6 Main Motor.....</b>	<b>3-36</b>
3.5.6.1 Removing the Cassette.....	3-36
3.5.6.2 Removing the front cover .....	3-36
3.5.6.3 Removing the right cover .....	3-36
3.5.6.4 Removing the left cover.....	3-37
3.5.6.5 Removing the rear cover.....	3-37
3.5.6.6 Removing the Scanner Unit.....	3-37
3.5.6.7 Removing the top cover.....	3-37
3.5.6.8 Removing the Right Frame.....	3-38
3.5.6.9 Removing the Plate.....	3-38
3.5.6.10 Removing the Left Frame .....	3-38
3.5.6.11 Removing the Power Supply Shield Plate.....	3-38
3.5.6.12 Removing the Power Supply Assembly .....	3-38
3.5.6.13 Removing the Main Motor .....	3-39
<b>3.5.7 Gear Unit.....</b>	<b>3-39</b>
3.5.7.1 Removing the Cassette.....	3-39
3.5.7.2 Removing the front cover .....	3-39
3.5.7.3 Removing the right cover .....	3-39
3.5.7.4 Removing the Gear Unit.....	3-39
<b>3.6 FIXING SYSTEM.....</b>	<b>3-40</b>
<b>3.6.1 Fixing Film Unit .....</b>	<b>3-40</b>
3.6.1.1 Removing the Cassette.....	3-40
3.6.1.2 Removing the front cover .....	3-40
3.6.1.3 Removing the right cover .....	3-40
3.6.1.4 Removing the left cover.....	3-40
3.6.1.5 Removing the rear cover.....	3-40
3.6.1.6 Removing the Scanner Unit.....	3-40
3.6.1.7 Removing the top cover.....	3-41
3.6.1.8 Removing the Right Frame.....	3-41
3.6.1.9 Removing the Plate.....	3-41

---



---

3.6.1.10 Removing the Left Frame .....	3-41
3.6.1.11 Removing the Power Supply Shield Plate .....	3-41
3.6.1.12 Removing the Fixing Film Unit .....	3-42
3.6.2 Fixing Pressure Roller .....	3-42
3.6.2.1 Removing the Cassette .....	3-42
3.6.2.2 Removing the front cover .....	3-42
3.6.2.3 Removing the right cover .....	3-42
3.6.2.4 Removing the left cover .....	3-43
3.6.2.5 Removing the rear cover .....	3-43
3.6.2.6 Removing the Scanner Unit .....	3-43
3.6.2.7 Removing the top cover .....	3-43
3.6.2.8 Removing the Right Frame .....	3-44
3.6.2.9 Removing the Plate .....	3-44
3.6.2.10 Removing the Left Frame .....	3-44
3.6.2.11 Removing the Power Supply Shield Plate .....	3-44
3.6.2.12 Removing the Fixing Film Unit .....	3-44
3.6.2.13 Removing the Fixing Pressure Roller .....	3-45



## 3.1 EXTERNAL AND CONTROLS SYSTEM

### 3.1.1 Front Cover

#### 3.1.1.1 Removing the Cassette

- 1) Remove the cassette by holding the cassette handle.

#### 3.1.1.2 Removing the front cover

- 1) Open the front cover [1] and remove the arm claws [2] to disengage the connection.
- 2) Remove the shafts on both sides [3] while warping the shaft arms inside, and remove the front cover.

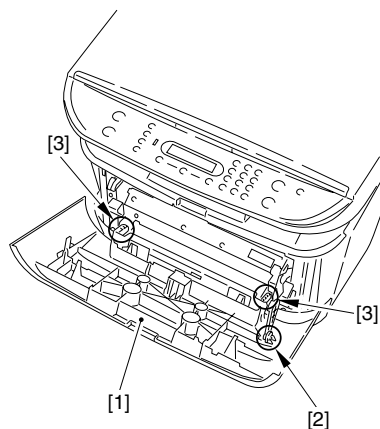

F-3-1

### 3.1.2 Rear Cover

#### 3.1.2.1 Removing the Cassette

- 1) Remove the cassette by holding the cassette handle.

#### 3.1.2.2 Removing the front cover

- 1) Open the front cover [1] and remove the arm claws [2] to disengage the connection.
- 2) Remove the shafts on both sides [3] while warping the shaft arms inside, and remove the front cover.

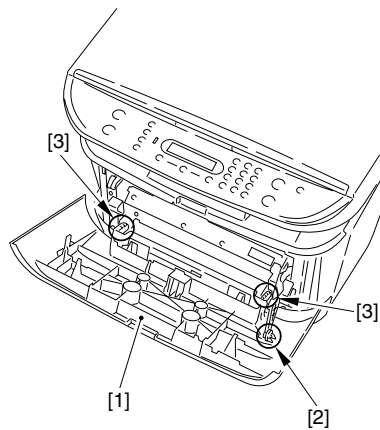

F-3-2

#### 3.1.2.3 Removing the right cover

- 1) Remove the 2 screws [1] on the right cover.

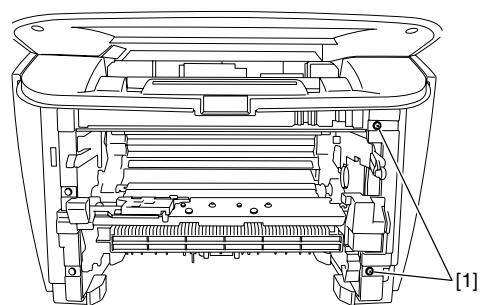

F-3-3

- 2) Remove the right cover [1].  
- 2 screws [2]

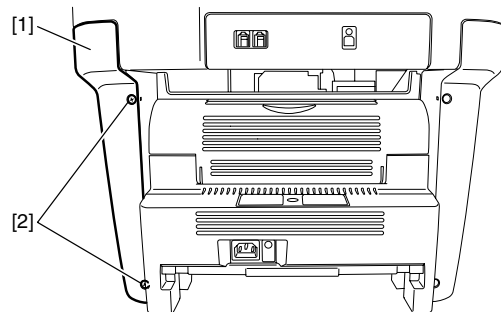

F-3-4

#### 3.1.2.4 Removing the left cover

- 1) Remove the 2 screws [1] on the left cover.

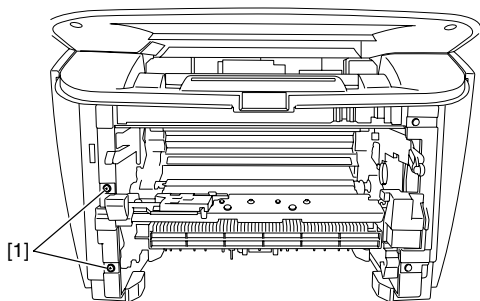

F-3-5

- 2) Remove the left cover [1].  
- 2 screws [2]

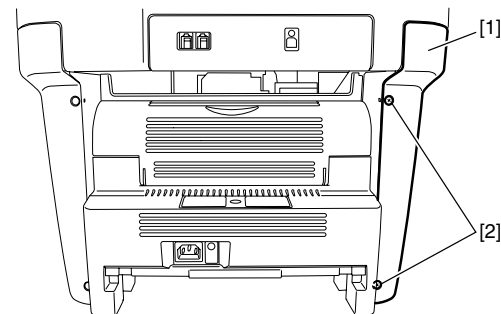

F-3-6

#### 3.1.2.5 Removing the rear cover

- 1) Opening the face-up cover [1], and then lower the fixing pressure release levers [2] on both sides and release the pressure.
- 2) Remove the rear cover [3] by sliding it to the rear.  
- 4 screws [4]

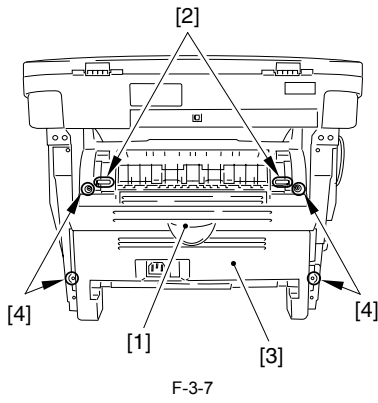

F-3-7

### 3.1.3 Top Cover

#### 3.1.3.1 Removing the Cassette

1) Remove the cassette by holding the cassette handle.

#### 3.1.3.2 Removing the front cover

- 1) Open the front cover [1] and remove the arm claws [2] to disengage the connection.
- 2) Remove the shafts on both sides [3] while warping the shaft arms inside, and remove the front cover.

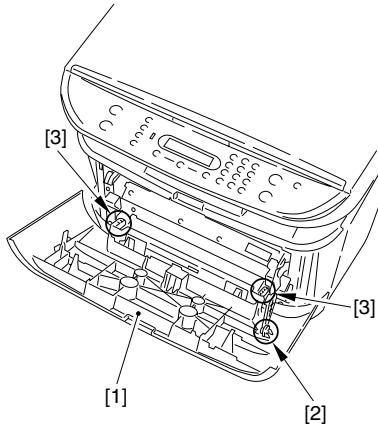

F-3-8

#### 3.1.3.3 Removing the right cover

1) Remove the 2 screws [1] on the right cover.

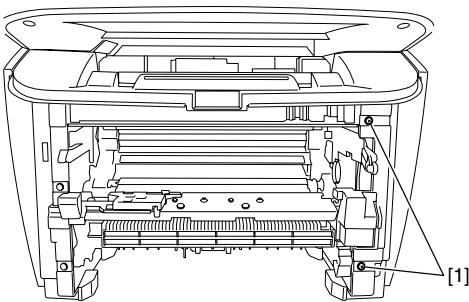

F-3-9

2) Remove the right cover [1].  
- 2 screws [2]

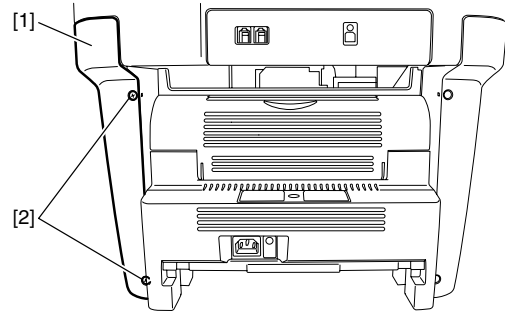

F-3-10

#### 3.1.3.4 Removing the left cover

1) Remove the 2 screws [1] on the left cover.

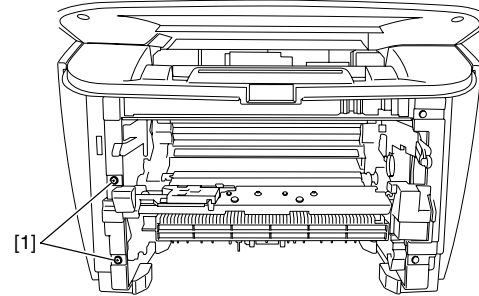

F-3-11

2) Remove the left cover [1].  
- 2 screws [2]

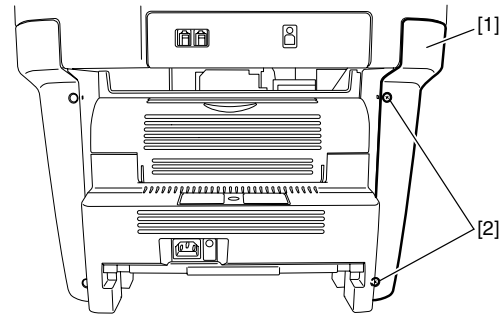

F-3-12

#### 3.1.3.5 Removing the rear cover

- 1) Opening the face-up cover [1], and then lower the fixing pressure release levers [2] on both sides and release the pressure.
- 2) Remove the rear cover [3] by sliding it to the rear.  
- 4 screws [4]

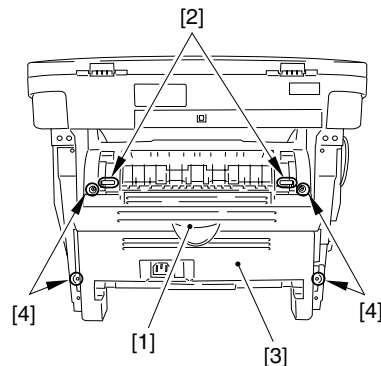

F-3-13

#### 3.1.3.6 Removing the Scanner Unit

1) Remove the connector [1] and the flat cable [2] on the ECNT board, and remove the screw [3]. (Remove the flat cable from the core.)

2) Remove the 2 screws [4] and the 2 pins [5] on the right and left sides.

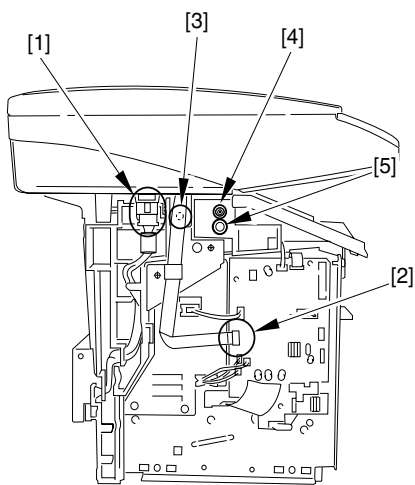

F-3-14

3) Remove the scanner unit [1] by sliding it to the rear and lifting it up.  
- 2 screws [2]

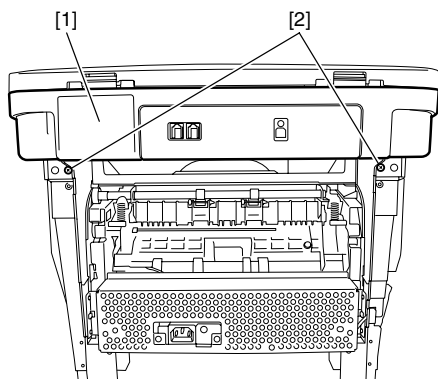

F-3-15

### 3.1.3.7 Removing the top cover

1) Free the 2 claws [1], and remove the top cover [2].  
- 2 screws [3]

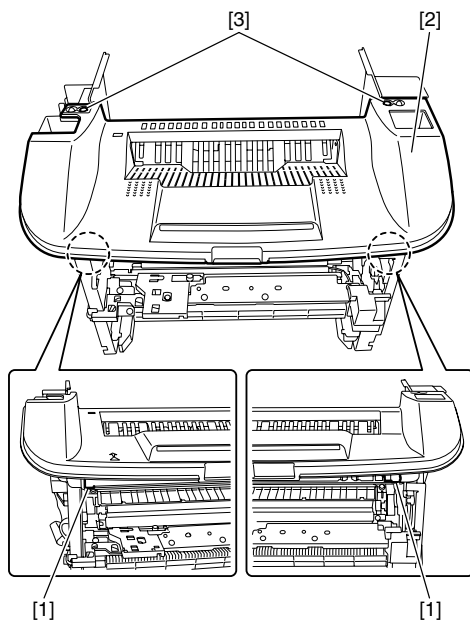

F-3-16

## 3.1.4 Right Cover

### 3.1.4.1 Removing the Cassette

1) Remove the cassette by holding the cassette handle.

### 3.1.4.2 Removing the front cover

1) Open the front cover [1] and remove the arm claws [2] to disengage the connection.  
2) Remove the shafts on both sides [3] while warping the shaft arms inside, and remove the front cover.

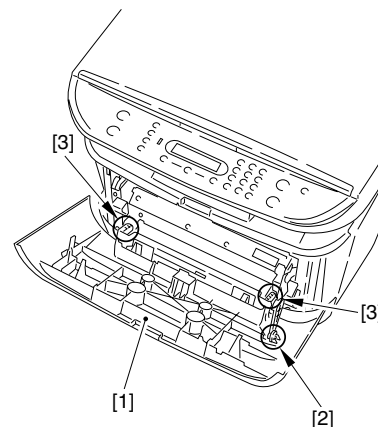

F-3-17

### 3.1.4.3 Removing the right cover

1) Remove the 2 screws [1] on the right cover.

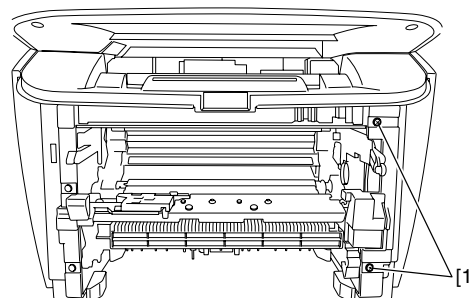

F-3-18

2) Remove the right cover [1].  
- 2 screws [2]

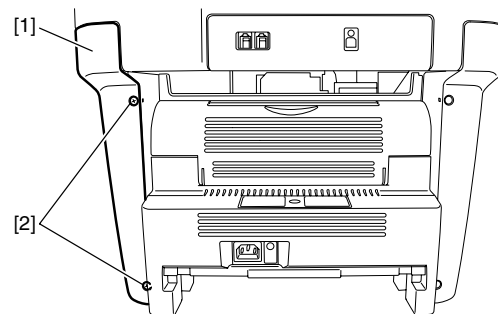

F-3-19

## 3.1.5 Left Cover

### 3.1.5.1 Removing the Cassette

1) Remove the cassette by holding the cassette handle.

### 3.1.5.2 Removing the left cover

1) Remove the 2 screws [1] on the left cover.

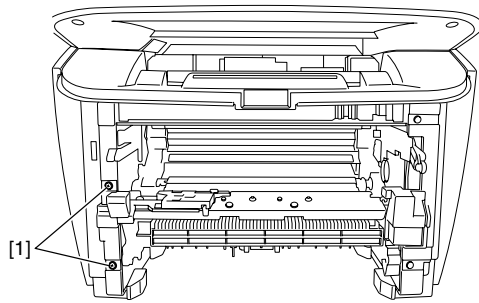

F-3-20

- 2) Remove the left cover [1].  
- 2 screws [2]

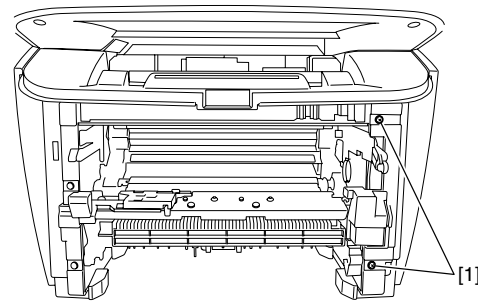

F-3-23

- 2) Remove the right cover [1].  
- 2 screws [2]

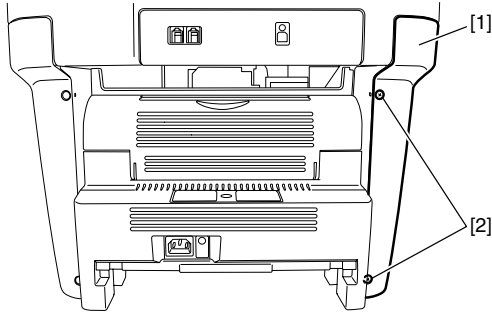

F-3-21

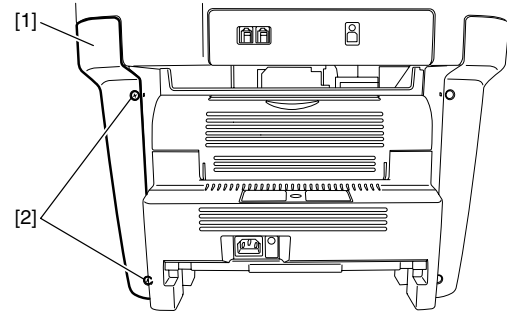

F-3-24

### 3.1.6 Operation Panel Unit

#### 3.1.6.1 Removing the Cassette

- 1) Remove the cassette by holding the cassette handle.

#### 3.1.6.2 Removing the front cover

- 1) Open the front cover [1] and remove the arm claws [2] to disengage the connection.  
2) Remove the shafts on both sides [3] while warping the shaft arms inside, and remove the front cover.

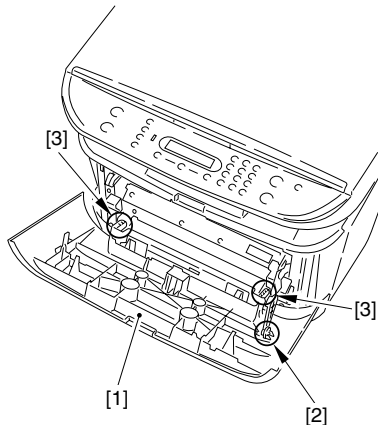

F-3-22

#### 3.1.6.3 Removing the right cover

- 1) Remove the 2 screws [1] on the right cover.

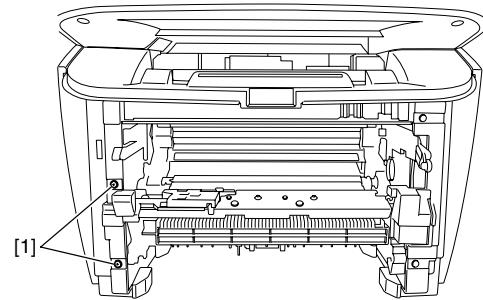

F-3-25

- 2) Remove the left cover [1].  
- 2 screws [2]

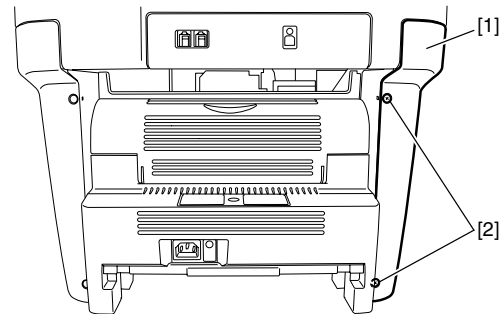

F-3-26

#### 3.1.6.5 Removing the rear cover

- 1) Opening the face-up cover [1], and then lower the fixing pressure release levers [2] on both sides and release the pressure.  
2) Remove the rear cover [3] by sliding it to the rear.  
- 4 screws [4]



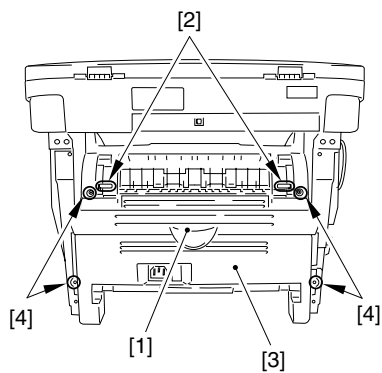

F-3-27

### 3.1.6.6 Removing the Scanner Unit

- 1) Remove the connector [1] and the flat cable [2] on the ECNT board, and remove the screw [3]. (Remove the flat cable from the core.)
- 2) Remove the 2 screws [4] and the 2 pins [5] on the right and left sides.

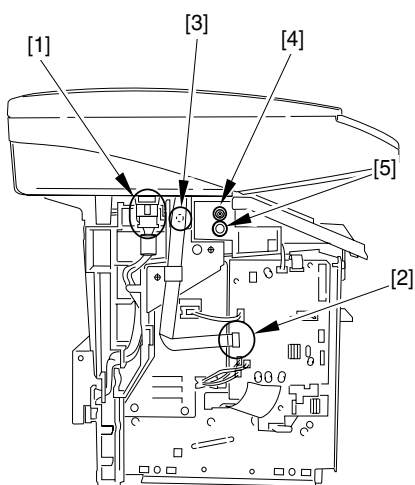

F-3-28

- 3) Remove the scanner unit [1] by sliding it to the rear and lifting it up. - 2 screws [2]

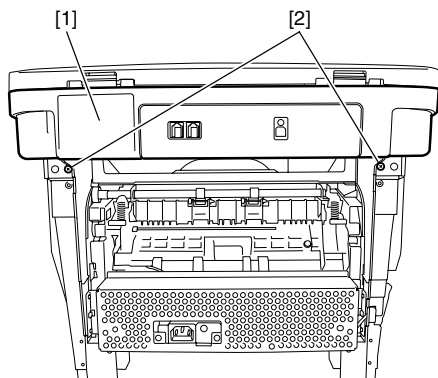

F-3-29

### 3.1.6.7 Removing the Board Unit

- 1) Remove the four screw [1] on the back of scanner unit.

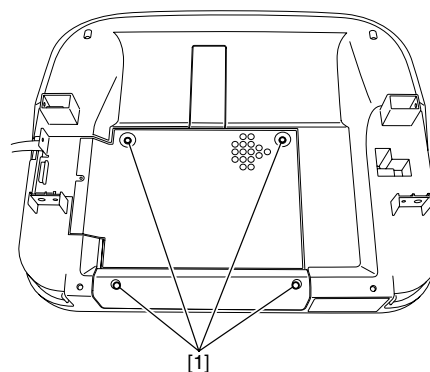

F-3-30

- 2) Open the board unit [1] and disconnect the connector [2] and two flat cables [3].

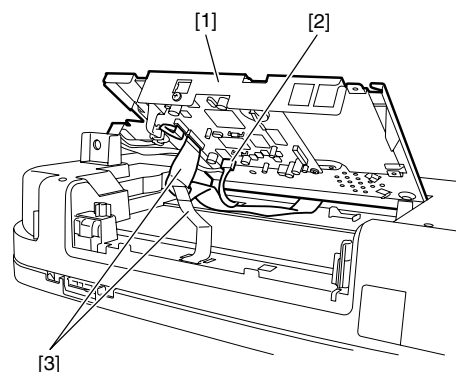

F-3-31

### 3.1.6.8 Removing the Operation Panel Unit

- 1) Detach the flat cable cover, and remove the flat cable [1] from the core [2]. - 2 screws [3]

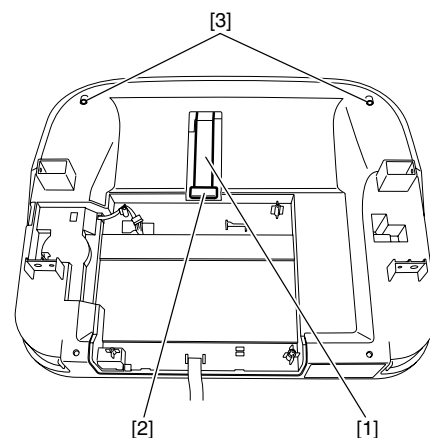

F-3-32

- 2) Remove the 2 claws [2] on the operation panel unit [1], and remove the operation panel unit.

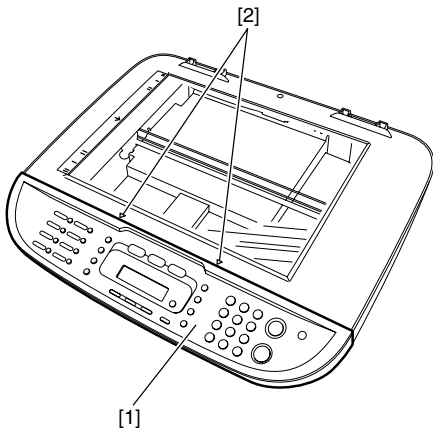

F-3-33

### 3.1.7 SCNT Board

#### 3.1.7.1 Removing the Cassette

- 1) Remove the cassette by holding the cassette handle.

#### 3.1.7.2 Removing the front cover

- 1) Open the front cover [1] and remove the arm claws [2] to disengage the connection.
- 2) Remove the shafts on both sides [3] while warping the shaft arms inside, and remove the front cover.

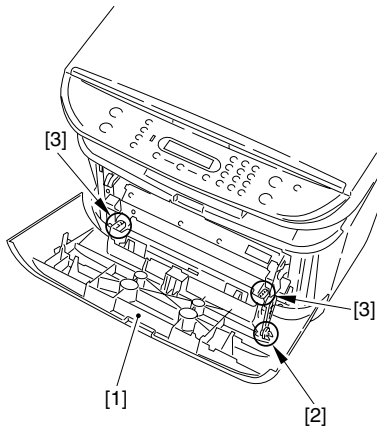

F-3-34

#### 3.1.7.3 Removing the right cover

- 1) Remove the 2 screws [1] on the right cover.

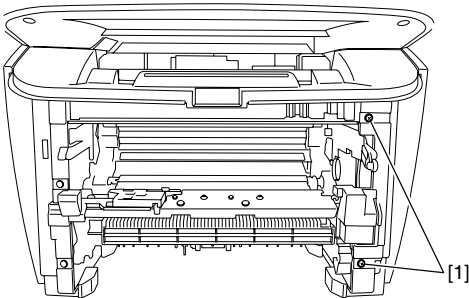

F-3-35

- 2) Remove the right cover [1].  
- 2 screws [2]

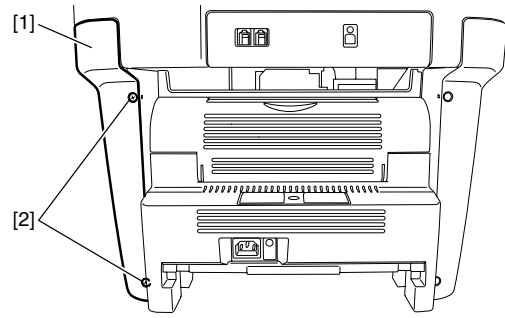

F-3-36

#### 3.1.7.4 Removing the left cover

- 1) Remove the 2 screws [1] on the left cover.

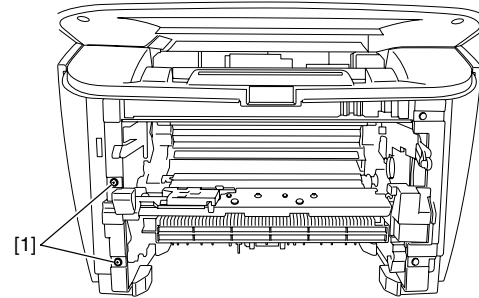

F-3-37

- 2) Remove the left cover [1].  
- 2 screws [2]

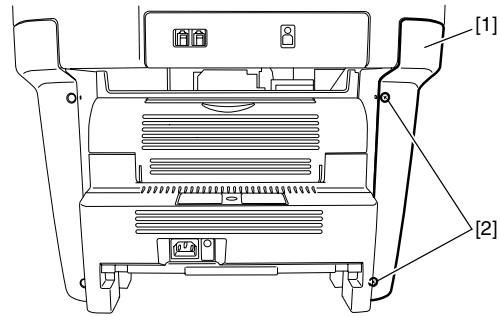

F-3-38

#### 3.1.7.5 Removing the rear cover

- 1) Opening the face-up cover [1], and then lower the fixing pressure release levers [2] on both sides and release the pressure.
- 2) Remove the rear cover [3] by sliding it to the rear.  
- 4 screws [4]

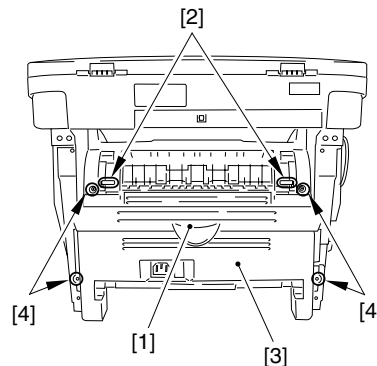

F-3-39

#### 3.1.7.6 Removing the Scanner Unit

- 1) Remove the connector [1] and the flat cable [2] on the ECNT board, and remove the screw [3]. (Remove the flat cable from the core.)

2) Remove the 2 screws [4] and the 2 pins [5] on the right and left sides.

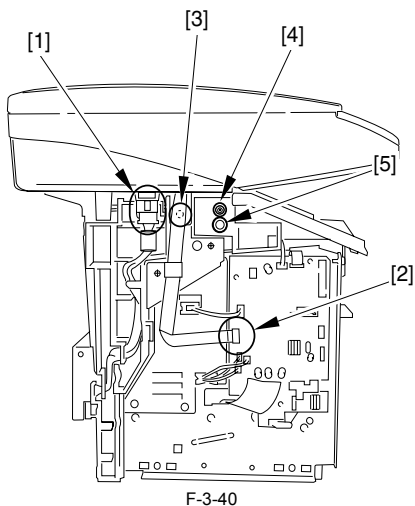

3) Remove the scanner unit [1] by sliding it to the rear and lifting it up.  
- 2 screws [2]

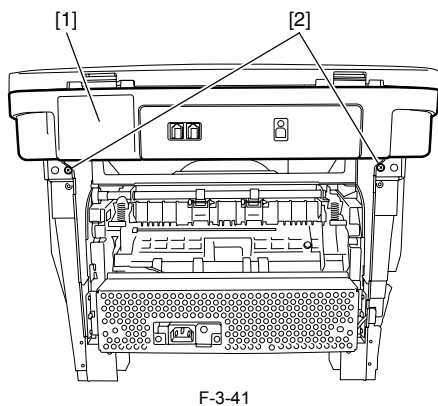

### 3.1.7.7 Removing the SCNT Board

1) Remove the SCNT PCB [1].  
- Two connectors [2]  
- Two flat cables [3]  
- Five screws [4]

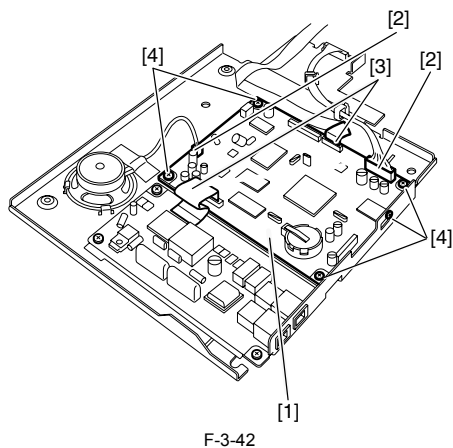

## 3.1.8 ECNT Board

### 3.1.8.1 Removing the Cassette

1) Remove the cassette by holding the cassette handle.

### 3.1.8.2 Removing the front cover

1) Open the front cover [1] and remove the arm claws [2] to disengage the connection.

2) Remove the shafts on both sides [3] while warping the shaft arms inside, and remove the front cover.

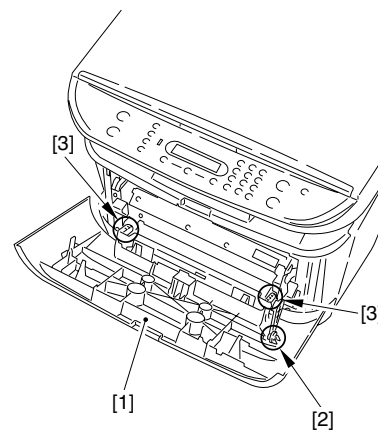

F-3-43

### 3.1.8.3 Removing the left cover

1) Remove the 2 screws [1] on the left cover.

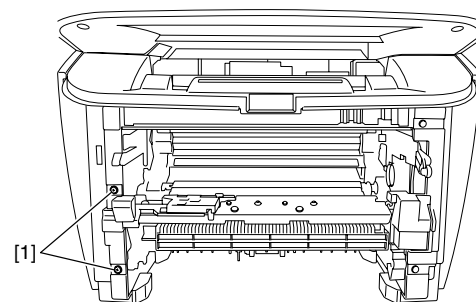

F-3-44

2) Remove the left cover [1].  
- 2 screws [2]

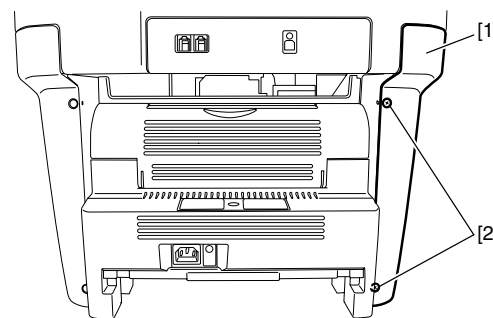

F-3-45

### 3.1.8.4 Removing the ECNT Board

1) Remove the 6 connectors [1] and 2 flat cables [2].  
2) Remove the wire saddle [3] and the connector [4].  
3) Remove the ECNT board [5], taking care not to damage the sensor flag.  
- 3 screws [6]

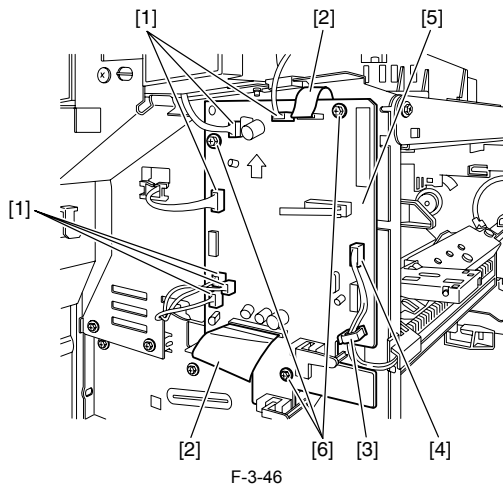

### 3.1.9 Power Supply PCB

#### 3.1.9.1 Removing the Cassette

- 1) Remove the cassette by holding the cassette handle.

#### 3.1.9.2 Removing the front cover

- 1) Open the front cover [1] and remove the arm claws [2] to disengage the connection.
- 2) Remove the shafts on both sides [3] while warping the shaft arms inside, and remove the front cover.

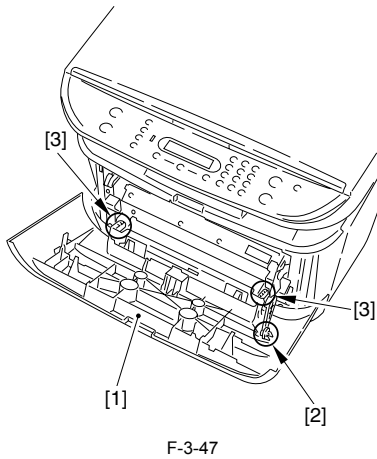

#### 3.1.9.3 Removing the right cover

- 1) Remove the 2 screws [1] on the right cover.

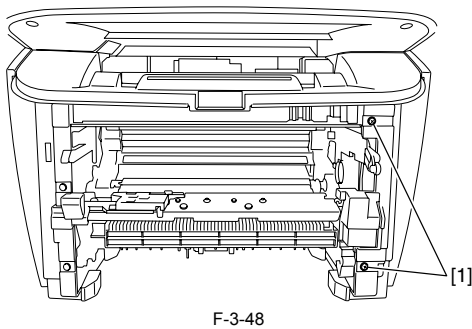

- 2) Remove the right cover [1].  
- 2 screws [2]

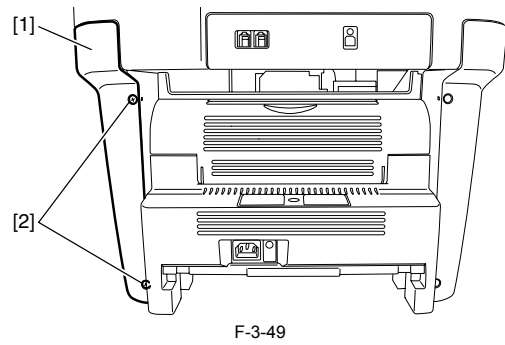

#### 3.1.9.4 Removing the left cover

- 1) Remove the 2 screws [1] on the left cover.

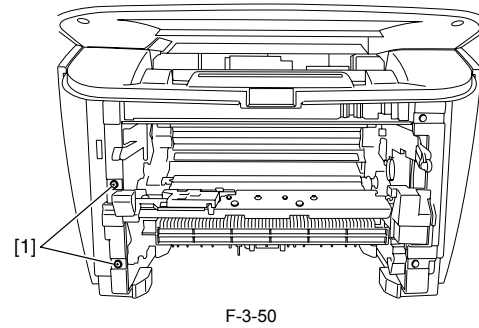

- 2) Remove the left cover [1].  
- 2 screws [2]

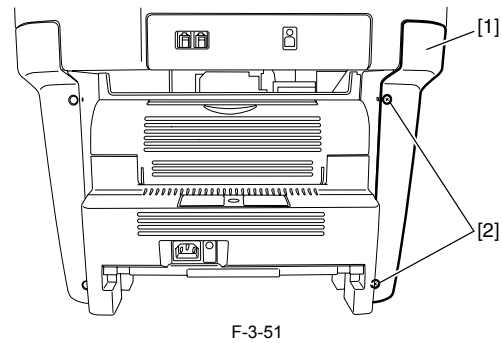

#### 3.1.9.5 Removing the rear cover

- 1) Opening the face-up cover [1], and then lower the fixing pressure release levers [2] on both sides and release the pressure.
- 2) Remove the rear cover [3] by sliding it to the rear.  
- 4 screws [4]

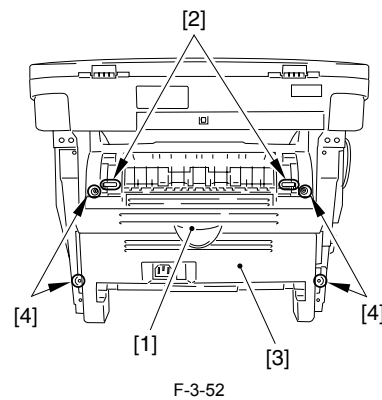

#### 3.1.9.6 Removing the Power Supply Shield Plate

- 1) Remove the cable from the cable guide.  
- 1 connector [1]

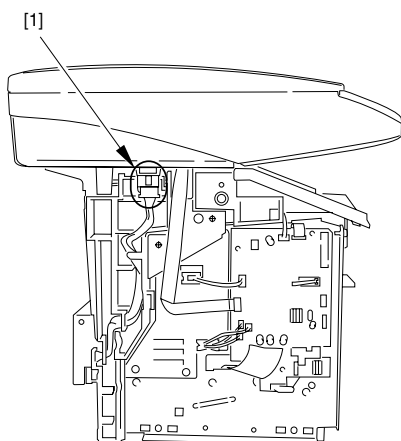

F-3-53

- 2) Remove the power supply shield plate [1].  
- 9 screws [2]

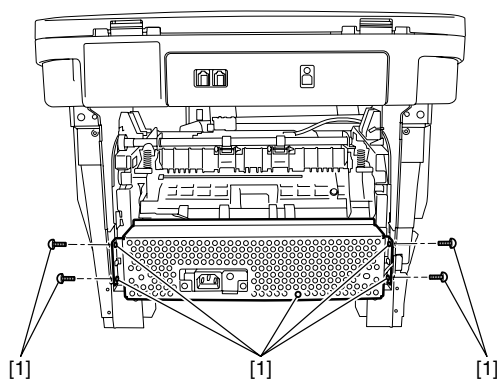

F-3-54

### 3.1.9.7 Removing the Power Supply Assembly

- 1) Remove the 3 screws [1]. (The external cover is omitted from the illustration below to show the instructions clearly.)
- 2) Remove the four connectors [2] as well as the flat cable [3] on the ECNT board.



After having removed the flat cable [3], store it inside the unit to protect it from damage.

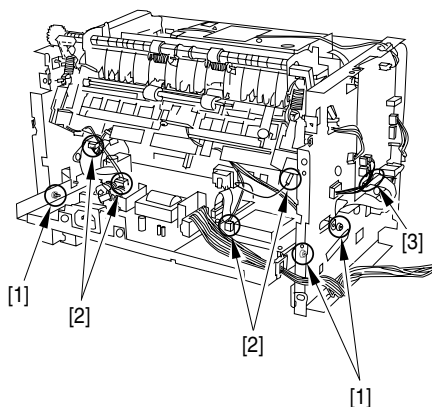

F-3-55

- 3) As you remove the bosses on both sides [1], lower the front part of the power supply assembly [2]. Then pull it to remove the power supply assembly.

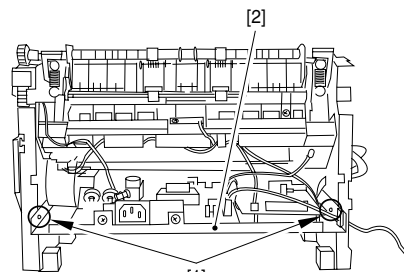

F-3-56

### 3.1.9.8 Removing the Power Supply Board

- 1) Remove the connector [1] and the flat cable [2].
- 2) Remove the power supply board [3].  
- 3 spacers [4]  
- 4 screws [5]

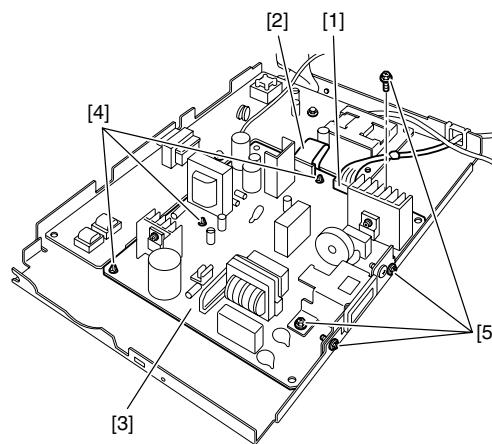

F-3-57

### 3.1.10 High-voltage Power Supply PCB

#### 3.1.10.1 Removing the Cassette

- 1) Remove the cassette by holding the cassette handle.

#### 3.1.10.2 Removing the front cover

- 1) Open the front cover [1] and remove the arm claws [2] to disengage the connection.
- 2) Remove the shafts on both sides [3] while warping the shaft arms inside, and remove the front cover.

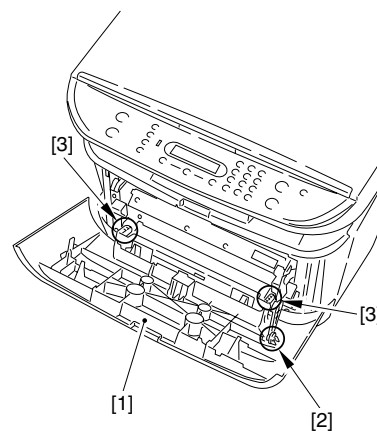

F-3-58

#### 3.1.10.3 Removing the right cover

- 1) Remove the 2 screws [1] on the right cover.

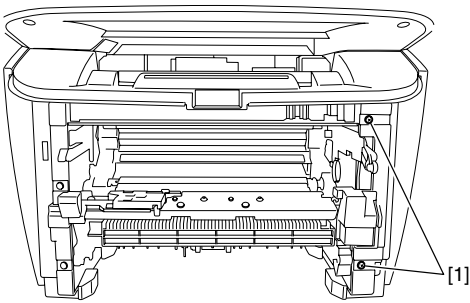

F-3-59

- 2) Remove the right cover [1].  
- 2 screws [2]

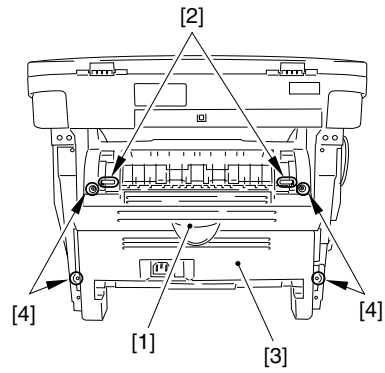

F-3-63

### 3.1.10.6 Removing the Power Supply Shield Plate

- 1) Remove the cable from the cable guide.  
- 1 connector [1]

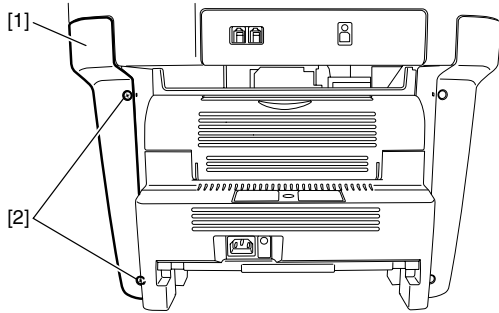

F-3-60

### 3.1.10.4 Removing the left cover

- 1) Remove the 2 screws [1] on the left cover.

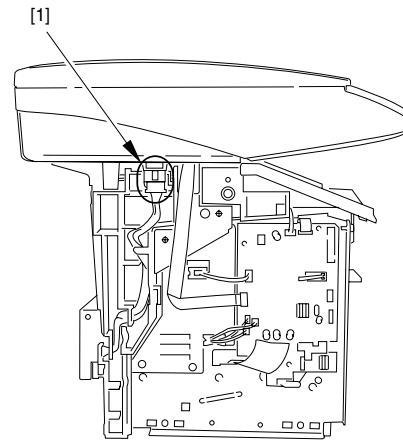

F-3-64

- 2) Remove the power supply shield plate [1].  
- 9 screws [2]

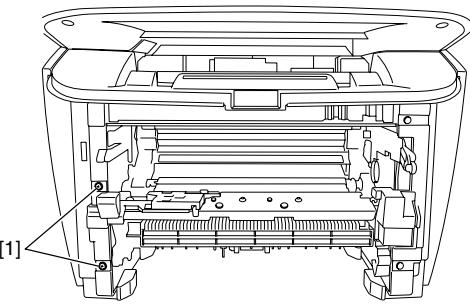

F-3-61

- 2) Remove the left cover [1].  
- 2 screws [2]

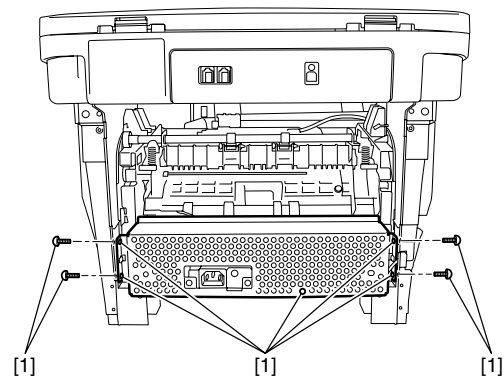

F-3-65

### 3.1.10.7 Removing the Power Supply Board

- 1) Remove the 3 screws [1]. (The external cover is omitted from the illustration below to show the instructions clearly.)  
2) Remove the four connectors [2] as well as the flat cable [3] on the ECNT board.



After having removed the flat cable [3], store it inside the unit to protect it from damage.

### 3.1.10.5 Removing the rear cover

- 1) Opening the face-up cover [1], and then lower the fixing pressure release levers [2] on both sides and release the pressure.  
2) Remove the rear cover [3] by sliding it to the rear.  
- 4 screws [4]

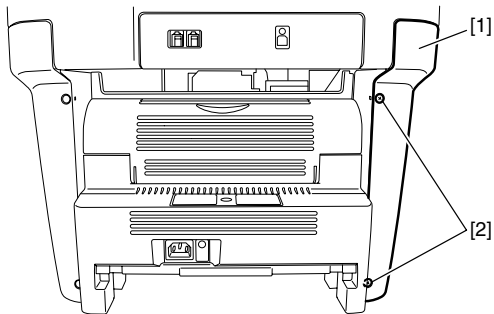

F-3-62

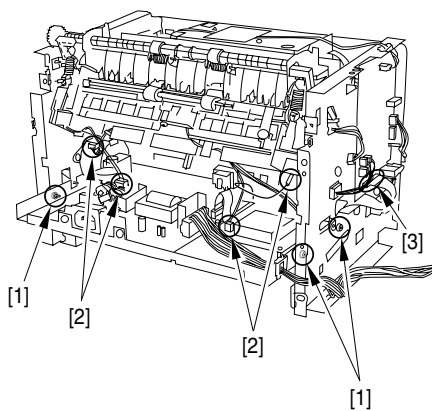

F-3-66

- 3) As you remove the bosses on both sides [1], lower the front part of the power supply assembly [2]. Then pull it to remove the power supply assembly.

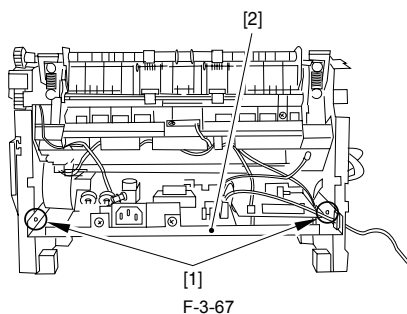

F-3-67

### 3.1.10.8 Removing the High-Voltage Power Supply Board

- 1) Remove the high-voltage power supply board [1].  
- One flat cable [2]  
- Three screws [3]

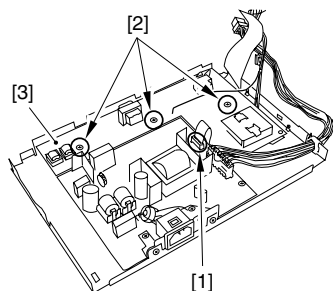

F-3-68

### 3.1.11 Top Sensor

#### 3.1.11.1 Removing the Cassette

- 1) Remove the cassette by holding the cassette handle.

#### 3.1.11.2 Removing the front cover

- 1) Open the front cover [1] and remove the arm claws [2] to disengage the connection.  
2) Remove the shafts on both sides [3] while warping the shaft arms inside, and remove the front cover.

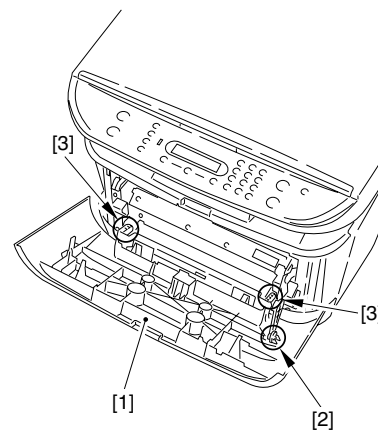

F-3-69

#### 3.1.11.3 Removing the right cover

- 1) Remove the 2 screws [1] on the right cover.

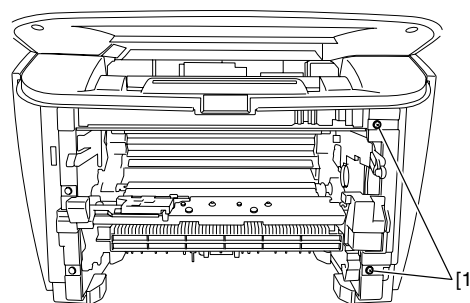

F-3-70

- 2) Remove the right cover [1].  
- 2 screws [2]

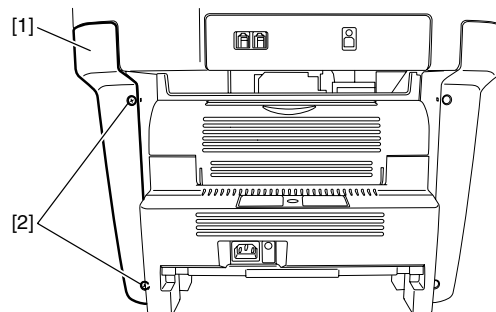

F-3-71

#### 3.1.11.4 Removing the left cover

- 1) Remove the 2 screws [1] on the left cover.

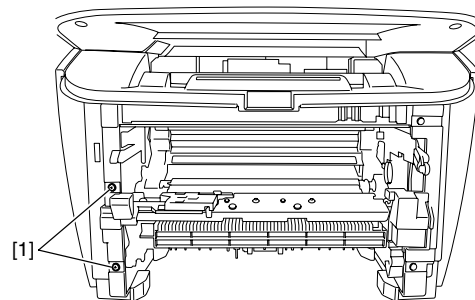

F-3-72

- 2) Remove the left cover [1].  
- 2 screws [2]

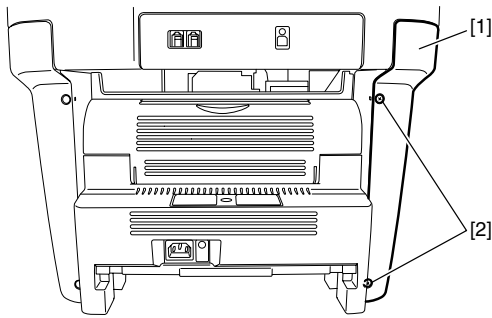

F-3-73

### 3.1.11.5 Removing the rear cover

- 1) Opening the face-up cover [1], and then lower the fixing pressure release levers [2] on both sides and release the pressure.
  - 2) Remove the rear cover [3] by sliding it to the rear.
- 4 screws [4]

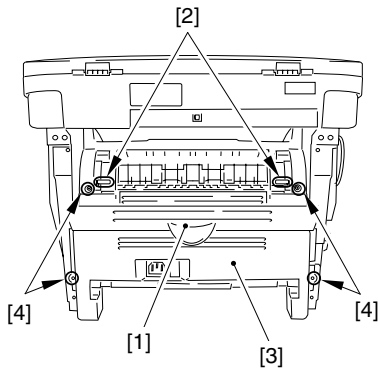

F-3-74

### 3.1.11.6 Removing the Scanner Unit

- 1) Remove the connector [1] and the flat cable [2] on the ECNT board, and remove the screw [3]. (Remove the flat cable from the core.)
- 2) Remove the 2 screws [4] and the 2 pins [5] on the right and left sides.

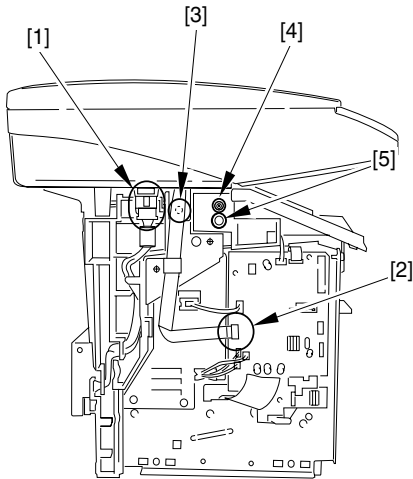

F-3-75

- 3) Remove the scanner unit [1] by sliding it to the rear and lifting it up.
- 2 screws [2]

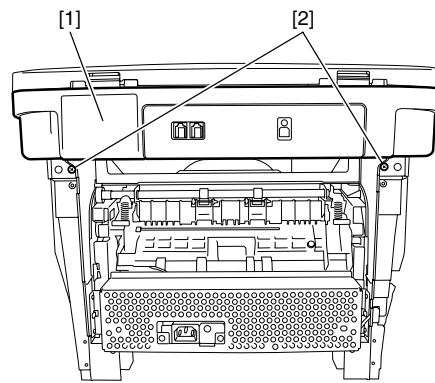

F-3-76

### 3.1.11.7 Removing the top cover

- 1) Free the 2 claws [1], and remove the top cover [2].
- 2 screws [3]

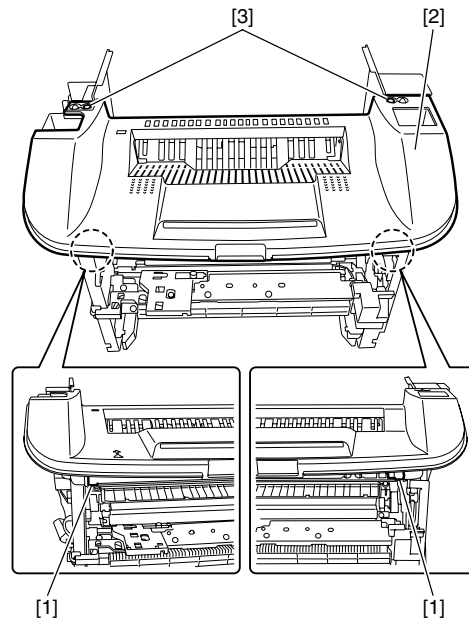

F-3-77

### 3.1.11.8 Removing the Right Frame

- 1) Remove the right frame [1].
- 3 screws [2]

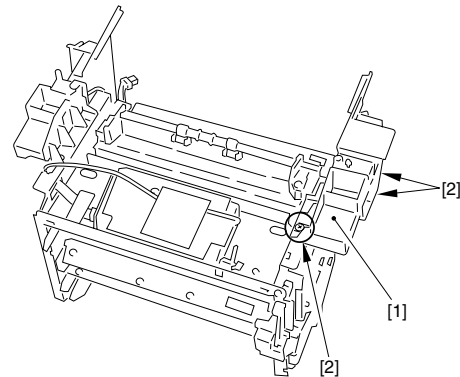

F-3-78

### 3.1.11.9 Removing the Plate

- 1) Remove the plate [1].
- 1 connector [2] on the ECNT board  
- 3 screws [3]



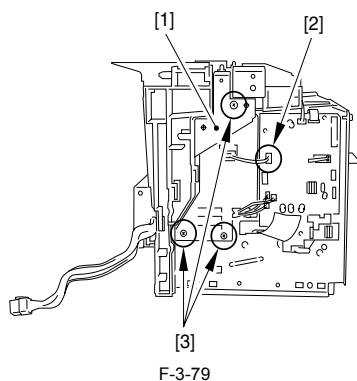

### 3.1.11.10 Removing the Left Frame

- 1) Remove the left frame [1].
- Remove the cable [2] from the guide.
- 3 screws [3]

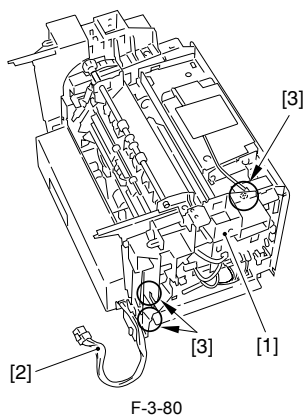

### 3.1.11.11 Removing the Power Supply Shield Plate

- 1) Remove the cable from the cable guide.
- 1 connector [1]

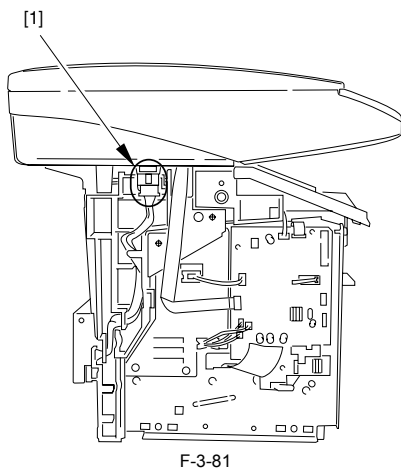

- 2) Remove the power supply shield plate [1].
- 9 screws [2]

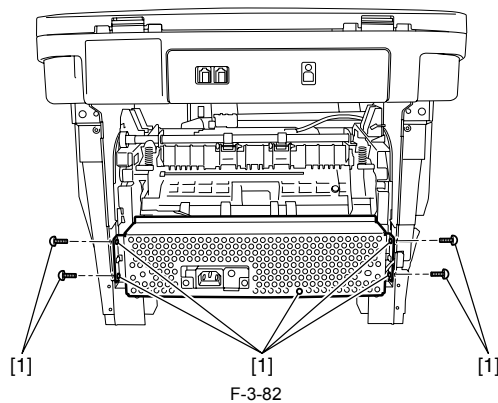

### 3.1.11.12 Removing the Power Supply Assembly

- 1) Remove the 3 screws [1]. (The external cover is omitted from the illustration below to show the instructions clearly.)
- 2) Remove the four connectors [2] as well as the flat cable [3] on the ECNT board.



After having removed the flat cable [3], store it inside the unit to protect it from damage.

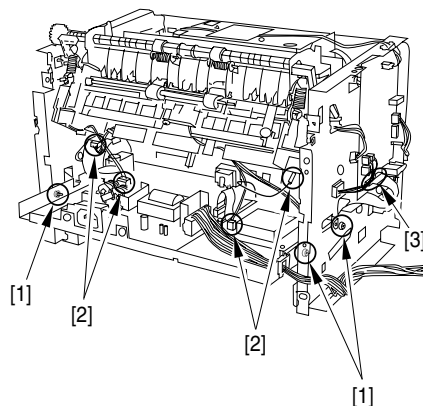

F-3-83

- 3) As you remove the bosses on both sides [1], lower the front part of the power supply assembly [2]. Then pull it to remove the power supply assembly.

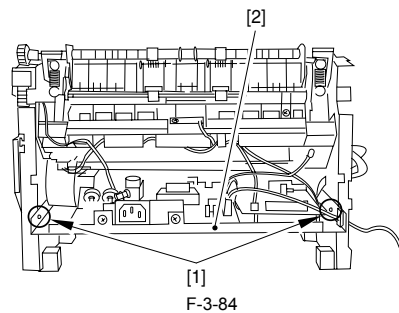

F-3-84

### 3.1.11.13 Removing the top sensor

- 1) Place the main unit down on its front face (so that the interior of the main unit is easily visible).
- 2) Remove the top sensor [1].
- 1 connector [2]
- 1 screw [3]

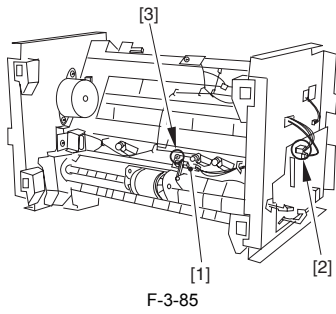

### 3.1.12 Paper Delivery Sensor

#### 3.1.12.1 Removing the Cassette

- 1) Remove the cassette by holding the cassette handle.

#### 3.1.12.2 Removing the front cover

- 1) Open the front cover [1] and remove the arm claws [2] to disengage the connection.
- 2) Remove the shafts on both sides [3] while warping the shaft arms inside, and remove the front cover.

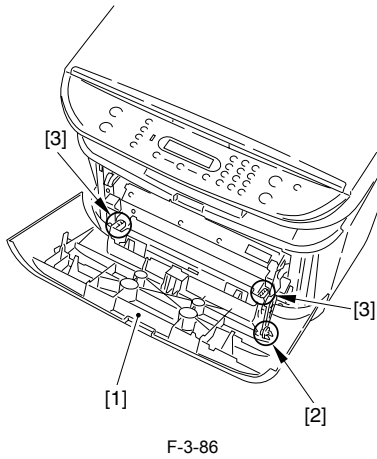

#### 3.1.12.3 Removing the right cover

- 1) Remove the 2 screws [1] on the right cover.

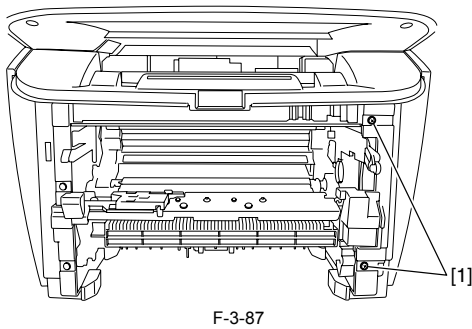

- 2) Remove the right cover [1].  
- 2 screws [2]

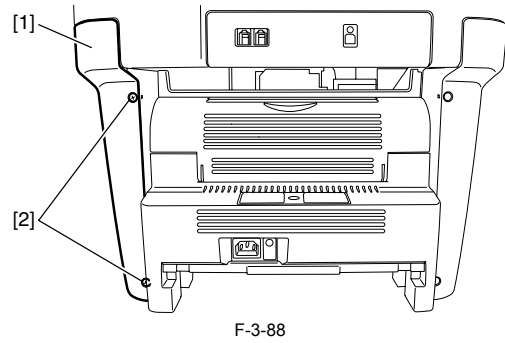

#### 3.1.12.4 Removing the left cover

- 1) Remove the 2 screws [1] on the left cover.

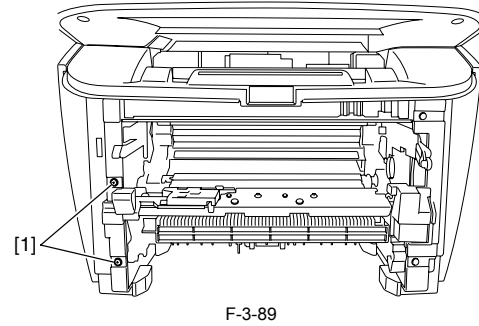

- 2) Remove the left cover [1].  
- 2 screws [2]

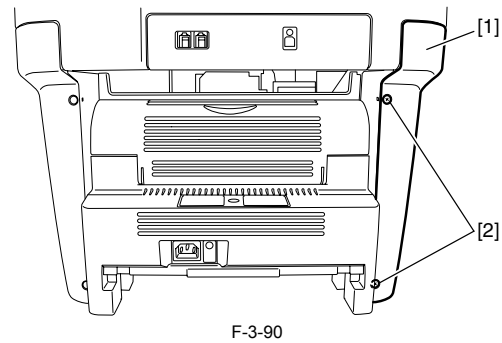

#### 3.1.12.5 Removing the rear cover

- 1) Opening the face-up cover [1], and then lower the fixing pressure release levers [2] on both sides and release the pressure.
- 2) Remove the rear cover [3] by sliding it to the rear.  
- 4 screws [4]

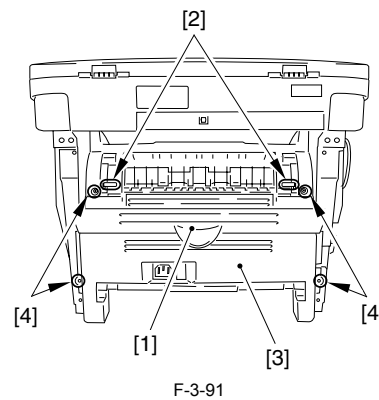

#### 3.1.12.6 Removing the Power Supply Shield Plate

- 1) Remove the cable from the cable guide.  
- 1 connector [1]

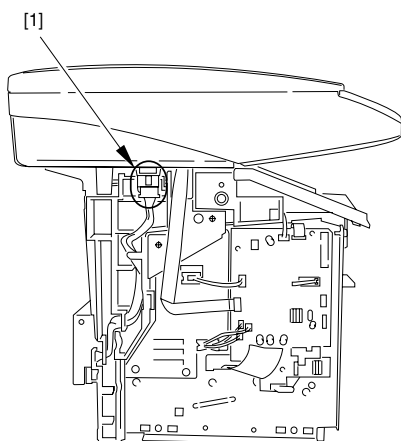

F-3-92

- 2) Remove the power supply shield plate [1].
- 9 screws [2]

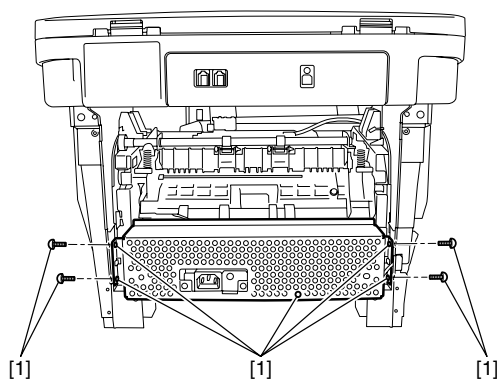

F-3-93

### 3.1.12.7 Removing the Scanner Unit

- 1) Remove the connector [1] and the flat cable [2] on the ECNT board, and remove the screw [3]. (Remove the flat cable from the core.)
- 2) Remove the 2 screws [4] and the 2 pins [5] on the right and left sides.

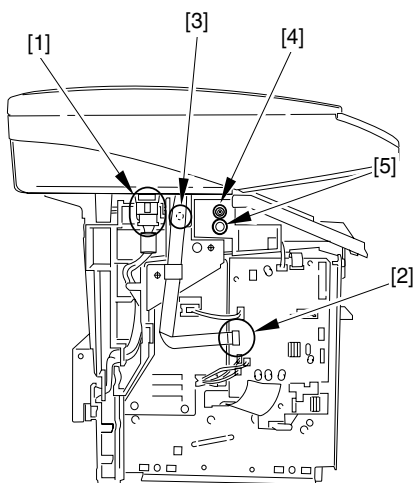

F-3-94

- 3) Remove the scanner unit [1] by sliding it to the rear and lifting it up.
- 2 screws [2]

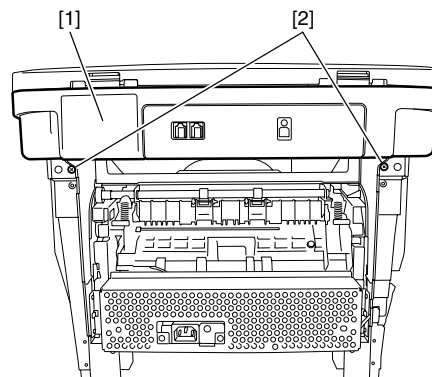

F-3-95

### 3.1.12.8 Removing the Plate

- 1) Remove the plate [1].
- 1 connector [2] on the ECNT board
- 3 screws [3]

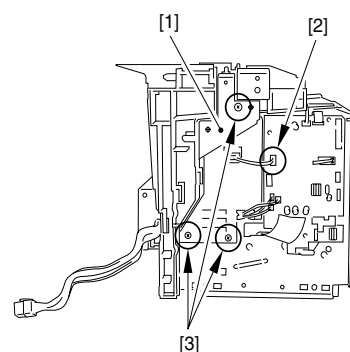

F-3-96

### 3.1.12.9 Removing the Paper Delivery Sensor

- 1) Remove the connector [1] on the ECNT board, and detach the cable from the cable guide. (For better visibility, the covers have been removed in the illustration.)
- 2) Remove the paper delivery sensor [2].
- 1 screw [3]

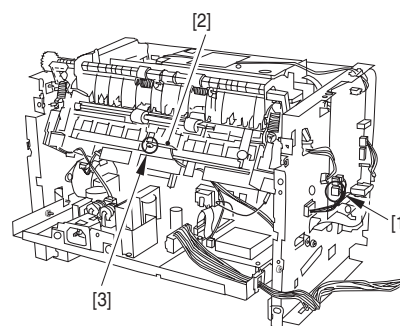

F-3-97

## 3.2 Document Feed/Exposure System

### 3.2.1 Scanner Unit

#### 3.2.1.1 Removing the Cassette

- 1) Remove the cassette by holding the cassette handle.

#### 3.2.1.2 Removing the front cover

- 1) Open the front cover [1] and remove the arm claws [2] to disengage the connection.
- 2) Remove the shafts on both sides [3] while warping the shaft arms inside, and remove the front cover.

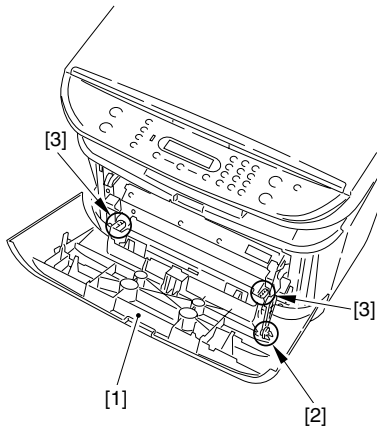

F-3-98

### 3.2.1.3 Removing the right cover

1) Remove the 2 screws [1] on the right cover.

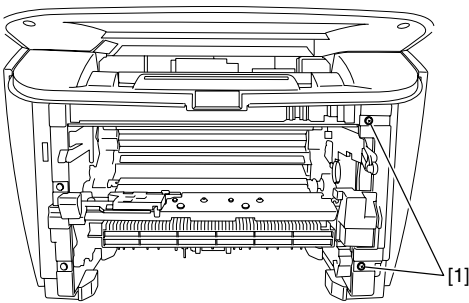

F-3-99

2) Remove the right cover [1].  
- 2 screws [2]

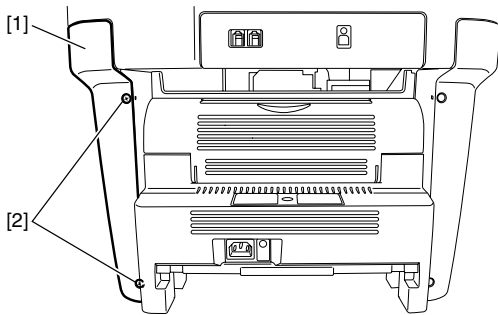

F-3-100

### 3.2.1.4 Removing the left cover

1) Remove the 2 screws [1] on the left cover.

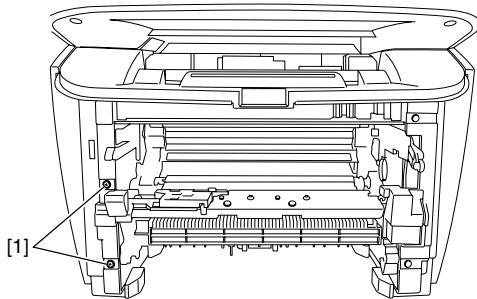

F-3-101

2) Remove the left cover [1].  
- 2 screws [2]

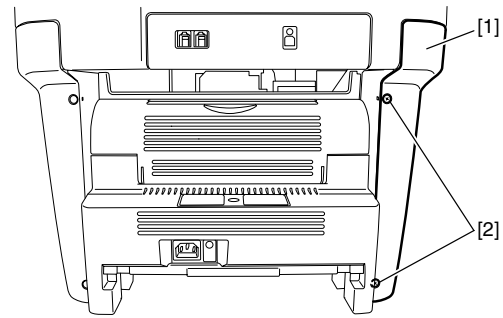

F-3-102

### 3.2.1.5 Removing the rear cover

1) Opening the face-up cover [1], and then lower the fixing pressure release levers [2] on both sides and release the pressure.  
2) Remove the rear cover [3] by sliding it to the rear.  
- 4 screws [4]

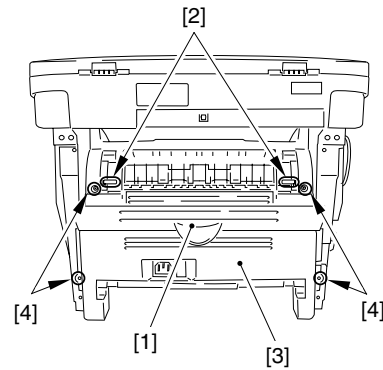

F-3-103

### 3.2.1.6 Removing the Scanner Unit

1) Remove the connector [1] and the flat cable [2] on the ECNT board, and remove the screw [3]. (Remove the flat cable from the core.)  
2) Remove the 2 screws [4] and the 2 pins [5] on the right and left sides.

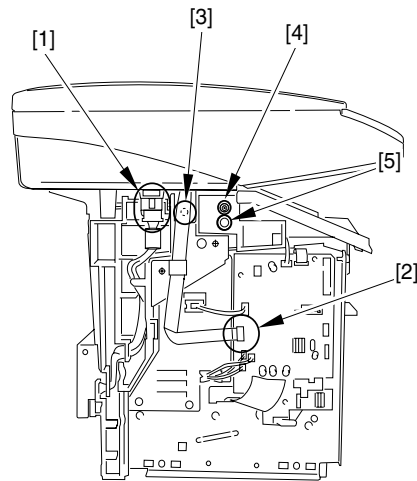

F-3-104

3) Remove the scanner unit [1] by sliding it to the rear and lifting it up.  
- 2 screws [2]

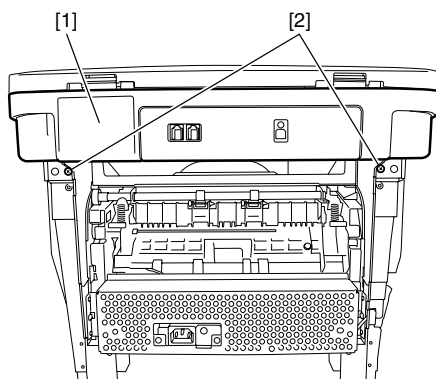

F-3-105

### 3.2.2 Scanner Cover Unit

#### 3.2.2.1 Removing the Cassette

- 1) Remove the cassette by holding the cassette handle.

#### 3.2.2.2 Removing the front cover

- 1) Open the front cover [1] and remove the arm claws [2] to disengage the connection.
- 2) Remove the shafts on both sides [3] while warping the shaft arms inside, and remove the front cover.

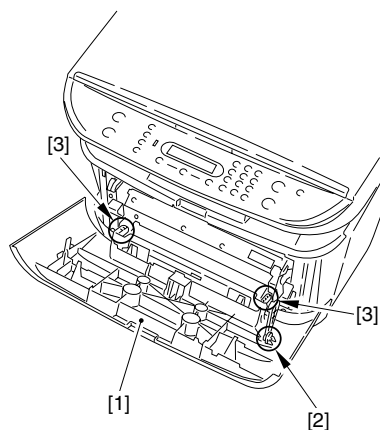

F-3-106

#### 3.2.2.3 Removing the right cover

- 1) Remove the 2 screws [1] on the right cover.

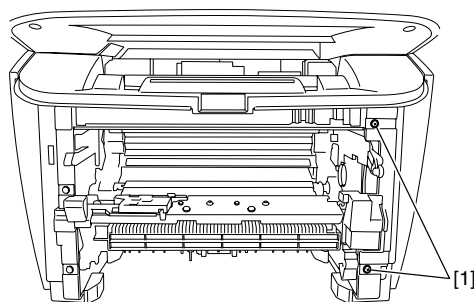

F-3-107

- 2) Remove the right cover [1].  
- 2 screws [2]

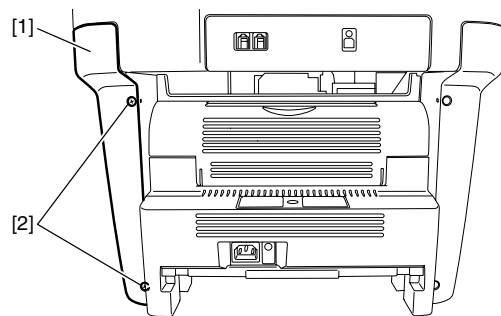

F-3-108

#### 3.2.2.4 Removing the left cover

- 1) Remove the 2 screws [1] on the left cover.

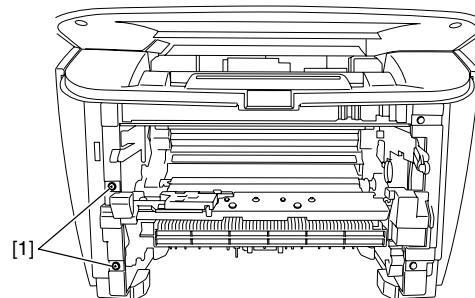

F-3-109

- 2) Remove the left cover [1].  
- 2 screws [2]

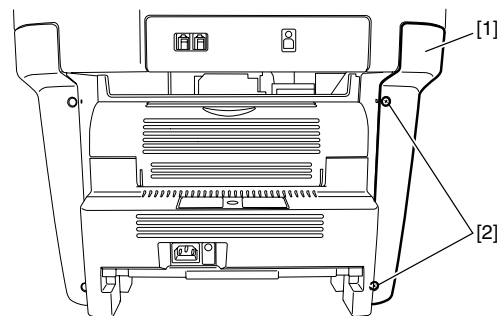

F-3-110

#### 3.2.2.5 Removing the rear cover

- 1) Opening the face-up cover [1], and then lower the fixing pressure release levers [2] on both sides and release the pressure.
- 2) Remove the rear cover [3] by sliding it to the rear.  
- 4 screws [4]

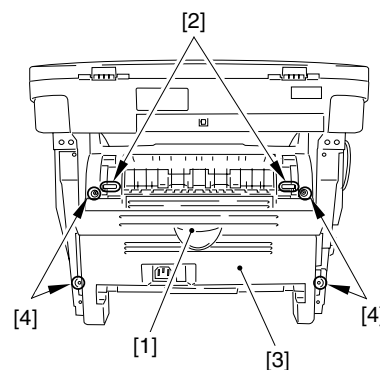

F-3-111

#### 3.2.2.6 Removing the Scanner Unit

- 1) Remove the connector [1] and the flat cable [2] on the ECNT board, and remove the screw [3]. (Remove the flat cable from the core.)

2) Remove the 2 screws [4] and the 2 pins [5] on the right and left sides.

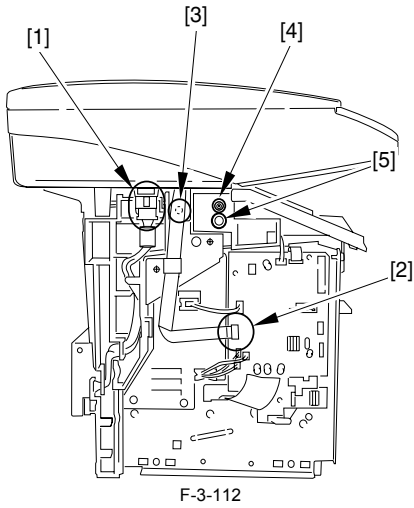

3) Remove the scanner unit [1] by sliding it to the rear and lifting it up.  
- 2 screws [2]

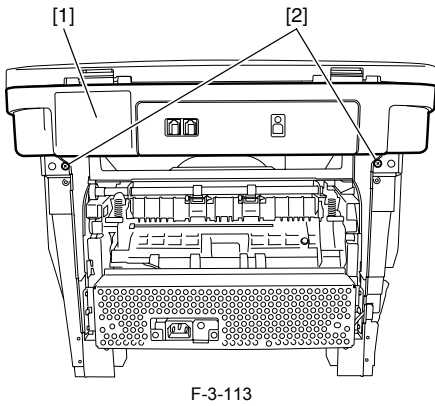

### 3.2.2.7 Removing the Operation Panel Unit

1) Detach the flat cable cover, and remove the flat cable [1] from the core [2].  
- 2 screws [3]

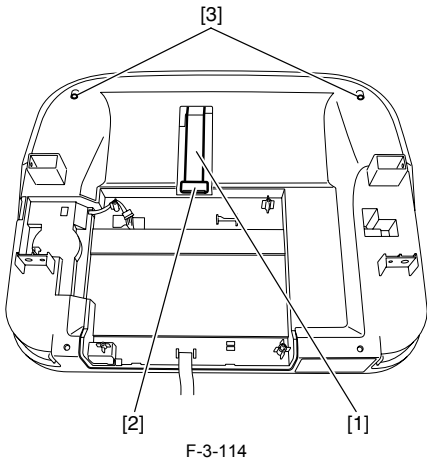

2) Remove the 2 claws [2] on the operation panel unit [1], and remove the operation panel unit.

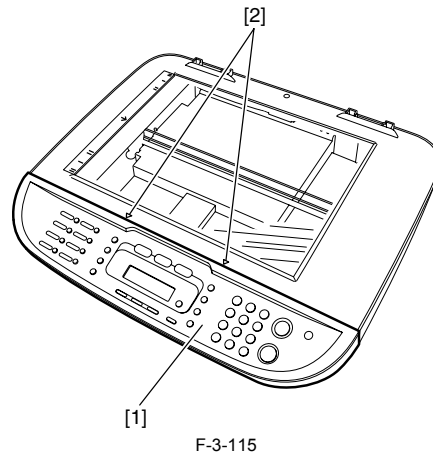

### 3.2.2.8 Scanner cover unit

1) Remove the platen glass cover.  
2) Remove the scanner cover unit [1].  
- 4 front claws [2]  
- 3 claws each on the right and left sides [3]  
- 3 screws [4]

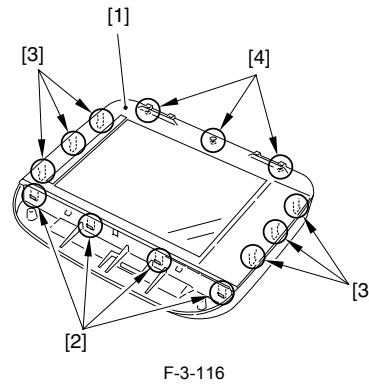

### 3.2.3 Contact Sensor

#### 3.2.3.1 Removing the Cassette

1) Remove the cassette by holding the cassette handle.

#### 3.2.3.2 Removing the front cover

1) Open the front cover [1] and remove the arm claws [2] to disengage the connection.  
2) Remove the shafts on both sides [3] while warping the shaft arms inside, and remove the front cover.

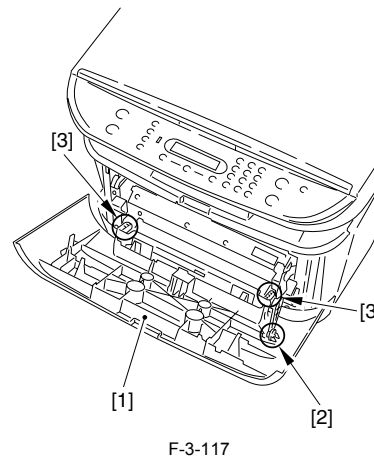

#### 3.2.3.3 Removing the right cover

1) Remove the 2 screws [1] on the right cover.

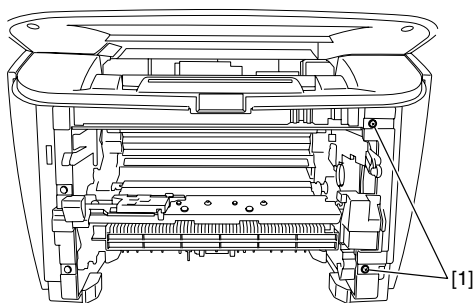

F-3-118

- 2) Remove the right cover [1].  
- 2 screws [2]

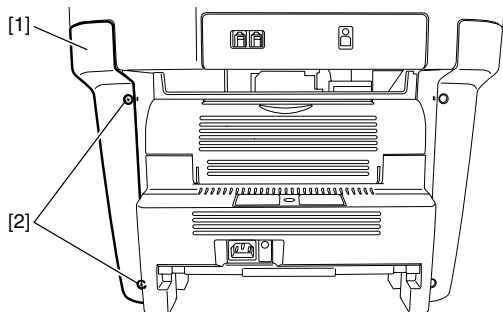

F-3-119

### 3.2.3.4 Removing the left cover

- 1) Remove the 2 screws [1] on the left cover.

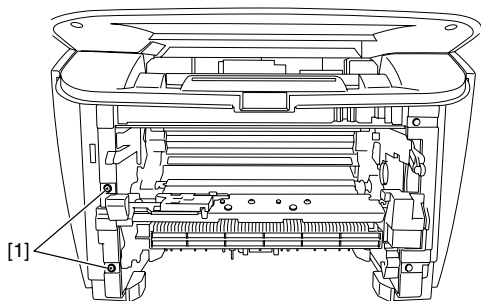

F-3-120

- 2) Remove the left cover [1].  
- 2 screws [2]

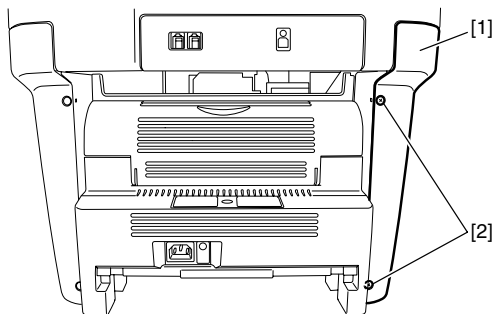

F-3-121

### 3.2.3.5 Removing the rear cover

- 1) Opening the face-up cover [1], and then lower the fixing pressure release levers [2] on both sides and release the pressure.  
2) Remove the rear cover [3] by sliding it to the rear.  
- 4 screws [4]

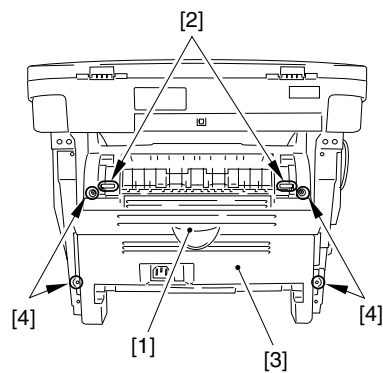

F-3-122

### 3.2.3.6 Removing the Scanner Unit

- 1) Remove the connector [1] and the flat cable [2] on the ECNT board, and remove the screw [3]. (Remove the flat cable from the core.)  
2) Remove the 2 screws [4] and the 2 pins [5] on the right and left sides.

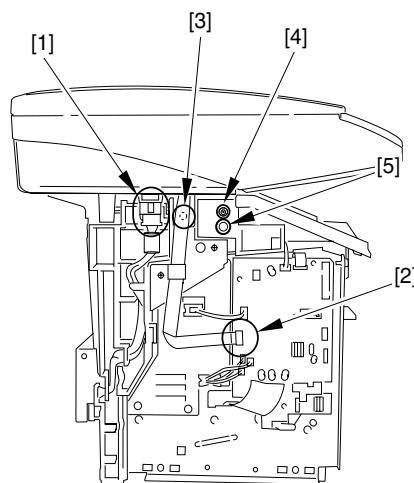

F-3-123

- 3) Remove the scanner unit [1] by sliding it to the rear and lifting it up.  
- 2 screws [2]

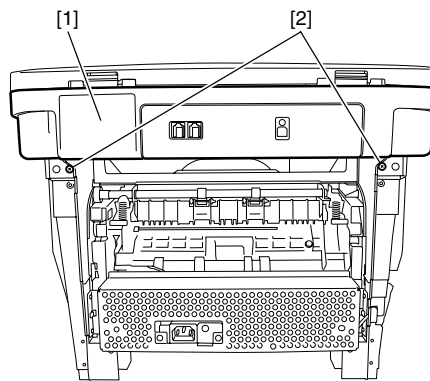

F-3-124

### 3.2.3.7 Removing the Operation Panel Unit

- 1) Detach the flat cable cover, and remove the flat cable [1] from the core [2].  
- 2 screws [3]

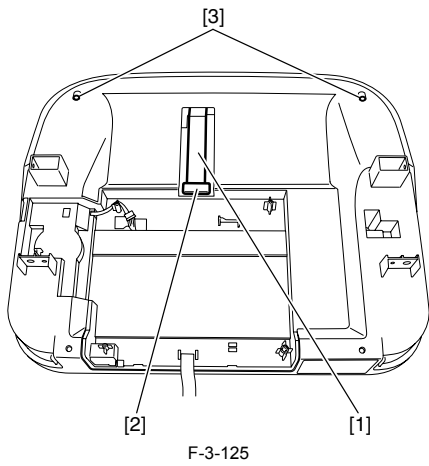

2) Remove the 2 claws [2] on the operation panel unit [1], and remove the operation panel unit.

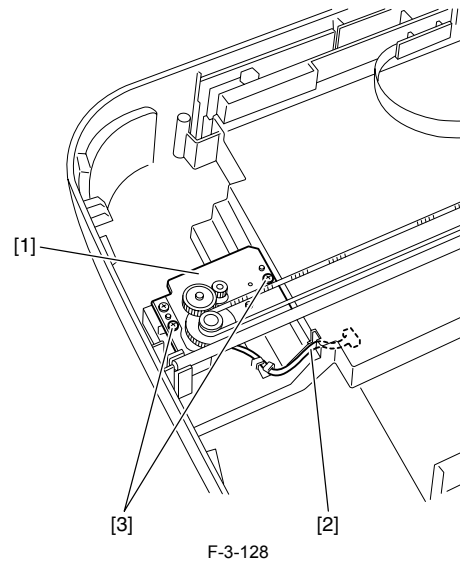

### 3.2.3.10 Removing the Contact Sensor

1) Remove the flat cable [1], and detach the contact sensor [3], while pushing the belt tension drive [2] in arrow direction.

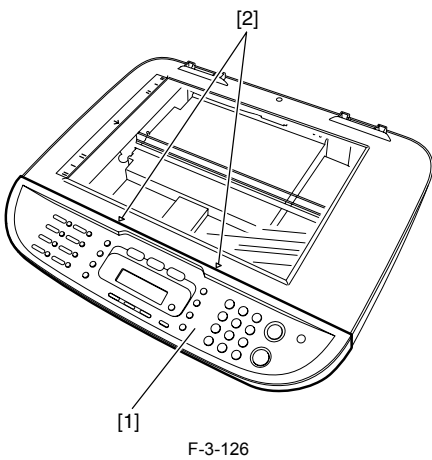

### 3.2.3.8 Removing the Scanner Cover Unit

- 1) Remove the platen glass cover.
- 2) Remove the scanner cover unit [1].
  - 4 front claws [2]
  - 3 claws each on the right and left sides [3]
  - 3 screws [4]

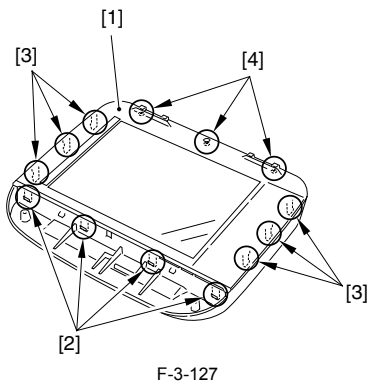
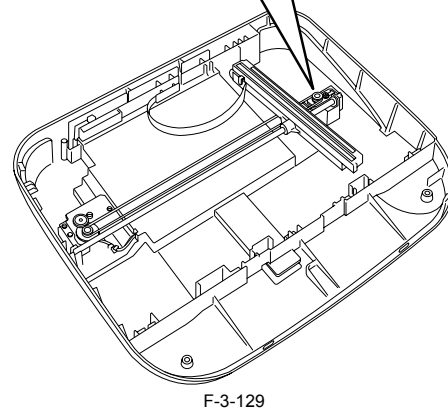
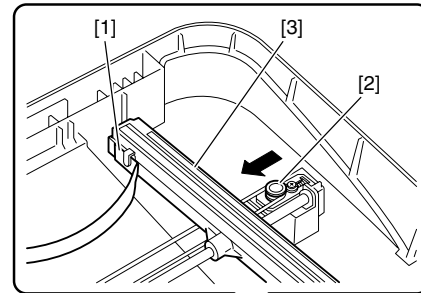

### 3.2.3.9 Removing the Flatbed Motor Unit

- 1) Remove the flat bed motor unit [1].
  - 1 connector [2] (remove from the rear)
  - 2 screws [3]

### 3.2.4 Flatbed Motor Unit

#### 3.2.4.1 Removing the Cassette

- 1) Remove the cassette by holding the cassette handle.

#### 3.2.4.2 Removing the front cover

- 1) Open the front cover [1] and remove the arm claws [2] to disengage the connection.
- 2) Remove the shafts on both sides [3] while warping the shaft arms inside, and remove the front cover.



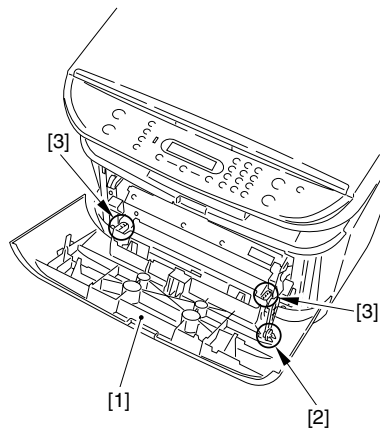

F-3-130

### 3.2.4.3 Removing the right cover

1) Remove the 2 screws [1] on the right cover.

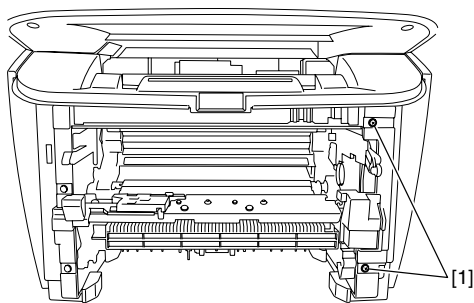

F-3-131

2) Remove the right cover [1].  
- 2 screws [2]

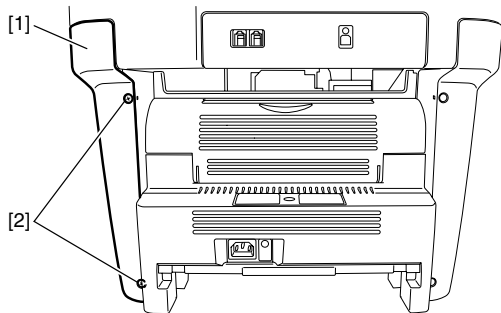

F-3-132

### 3.2.4.4 Removing the left cover

1) Remove the 2 screws [1] on the left cover.

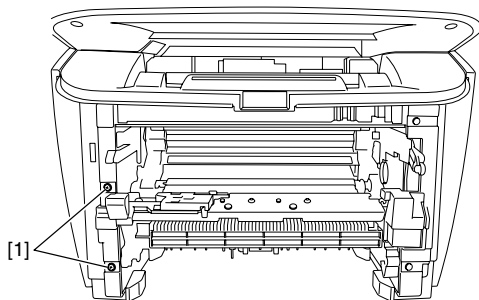

F-3-133

2) Remove the left cover [1].  
- 2 screws [2]

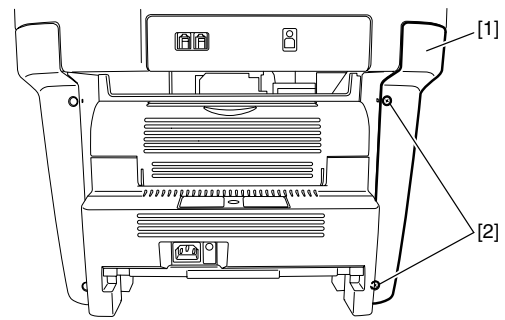

F-3-134

### 3.2.4.5 Removing the rear cover

1) Opening the face-up cover [1], and then lower the fixing pressure release levers [2] on both sides and release the pressure.  
2) Remove the rear cover [3] by sliding it to the rear.  
- 4 screws [4]

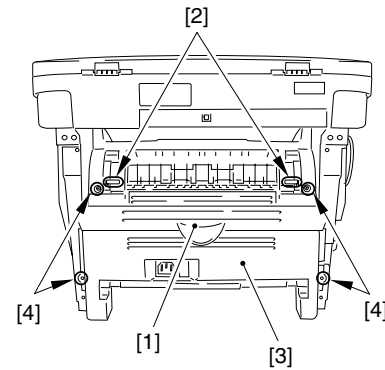

F-3-135

### 3.2.4.6 Removing the Scanner Unit

1) Remove the connector [1] and the flat cable [2] on the ECNT board, and remove the screw [3]. (Remove the flat cable from the core.)  
2) Remove the 2 screws [4] and the 2 pins [5] on the right and left sides.

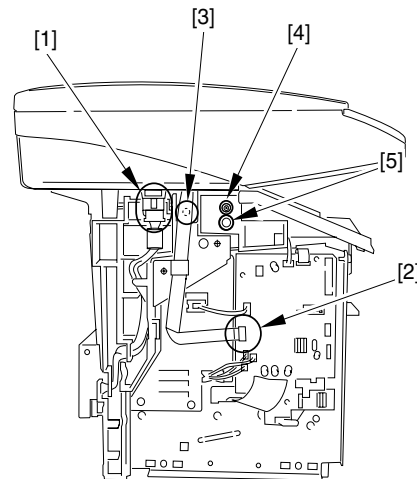

F-3-136

3) Remove the scanner unit [1] by sliding it to the rear and lifting it up.  
- 2 screws [2]

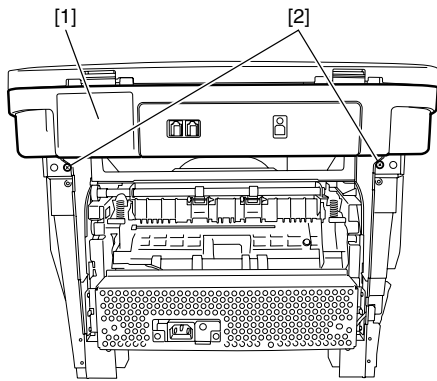

F-3-137

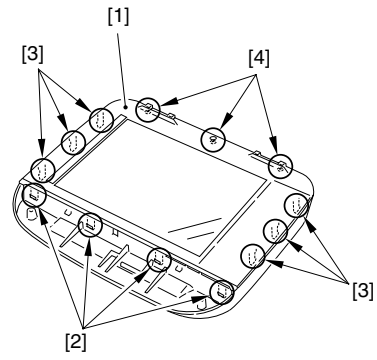

F-3-140

**3.2.4.7 Removing the Operation Panel Unit**

- 1) Detach the flat cable cover, and remove the flat cable [1] from the core [2].
- 2 screws [3]

**3.2.4.9 Removing the Flatbed Motor Unit**

- 1) Remove the flat bed motor unit [1].
- 1 connector [2] (remove from the rear)
- 2 screws [3]

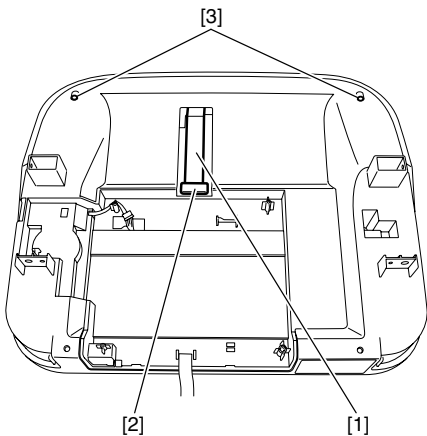

F-3-138

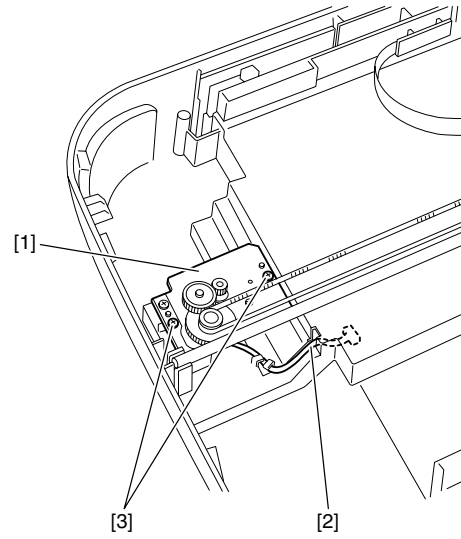

F-3-141

- 2) Remove the 2 claws [2] on the operation panel unit [1], and remove the operation panel unit.

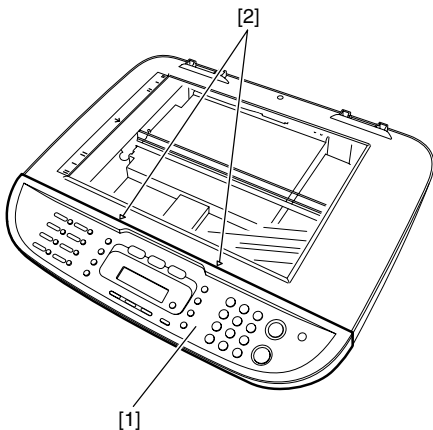

F-3-139

**3.2.4.8 Removing the Scanner Cover Unit**

- 1) Remove the platen glass cover.
- 2) Remove the scanner cover unit [1].
- 4 front claws [2]
- 3 claws each on the right and left sides [3]
- 3 screws [4]

**3.3 LASER EXPOSURE SYSTEM**

**3.3.1 Laser/Scanner Unit**

**3.3.1.1 Removing the Cassette**

- 1) Remove the cassette by holding the cassette handle.

**3.3.1.2 Removing the front cover**

- 1) Open the front cover [1] and remove the arm claws [2] to disengage the connection.
- 2) Remove the shafts on both sides [3] while warping the shaft arms inside, and remove the front cover.

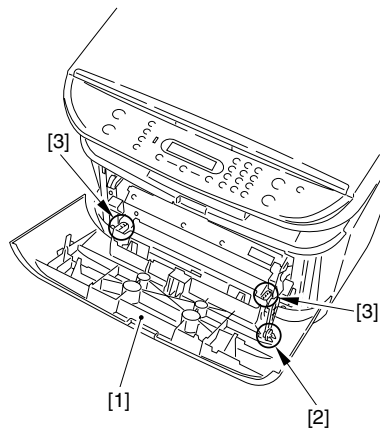

F-3-142

### 3.3.1.3 Removing the right cover

1) Remove the 2 screws [1] on the right cover.

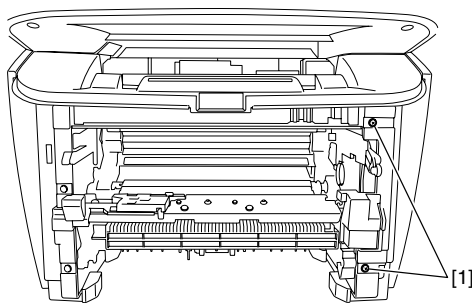

F-3-143

2) Remove the right cover [1].  
- 2 screws [2]

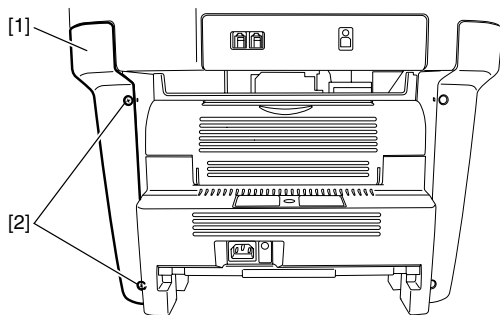

F-3-144

### 3.3.1.4 Removing the left cover

1) Remove the 2 screws [1] on the left cover.

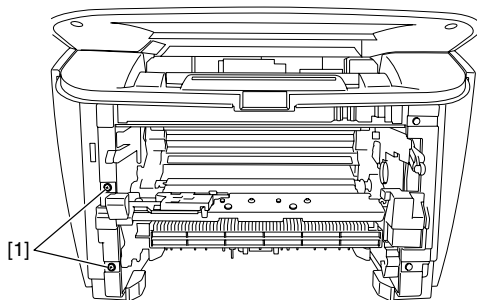

F-3-145

2) Remove the left cover [1].  
- 2 screws [2]

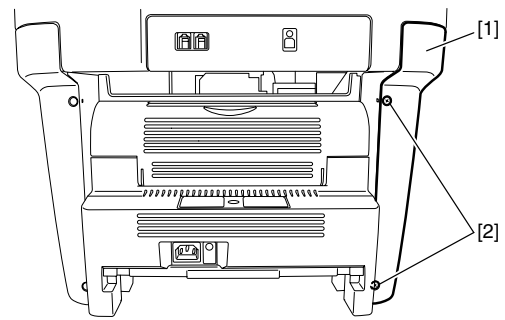

F-3-146

### 3.3.1.5 Removing the rear cover

1) Opening the face-up cover [1], and then lower the fixing pressure release levers [2] on both sides and release the pressure.  
2) Remove the rear cover [3] by sliding it to the rear.  
- 4 screws [4]

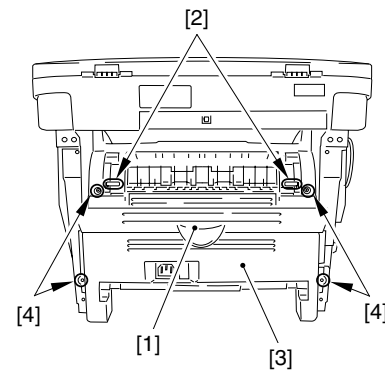

F-3-147

### 3.3.1.6 Removing the Scanner Unit

1) Remove the connector [1] and the flat cable [2] on the ECNT board, and remove the screw [3]. (Remove the flat cable from the core.)  
2) Remove the 2 screws [4] and the 2 pins [5] on the right and left sides.

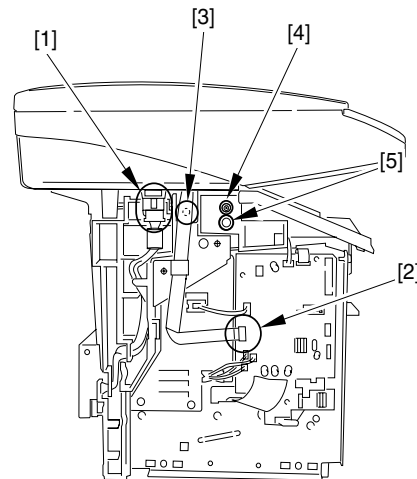

F-3-148

3) Remove the scanner unit [1] by sliding it to the rear and lifting it up.  
- 2 screws [2]

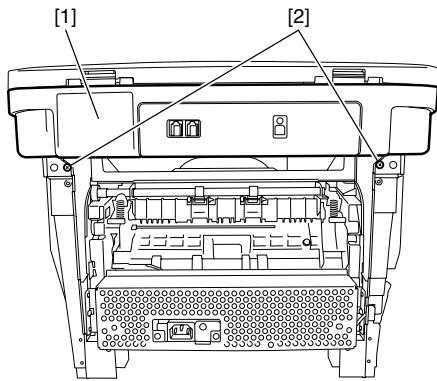

F-3-149

### 3.3.1.7 Removing the top cover

- 1) Free the 2 claws [1], and remove the top cover [2].
- 2 screws [3]

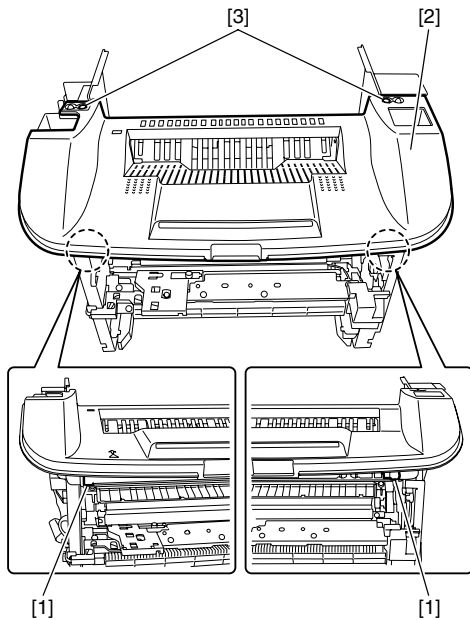

F-3-150

### 3.3.1.8 Removing the Laser/Scanner Unit

- 1) Remove the laser scanner unit [1]. (For better visibility, the covers, etc. have been removed in the illustration.)
- 1 flat cable [2]
- 1 connector [3]
- 4 screws [4]



When removing the laser scanner unit, take care not to lose the grounding plate [5].

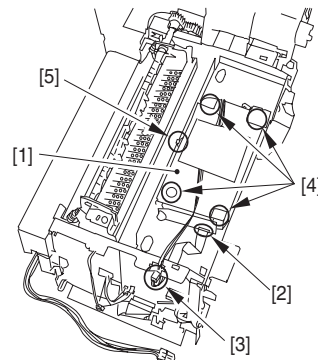

F-3-151

## 3.4 IMAGE FORMATION SYSTEM

### 3.4.1 Transfer Charging Roller

#### 3.4.1.1 Removing the Transfer Charging Roller

- 1) Open the front cover.
- 2) Hold the 2 claws [1] on the right side of the roller, lifting them up.
- 3) Slide the transfer charging roller [2] by sliding it to the right.

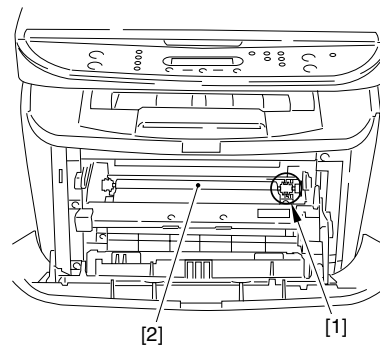

F-3-152

## 3.5 PICKUP AND FEEDING SYSTEM

### 3.5.1 Cassette Pickup Roller

#### 3.5.1.1 Removing the Cassette

- 1) Remove the cassette by holding the cassette handle.

#### 3.5.1.2 Removing the front cover

- 1) Open the front cover [1] and remove the arm claws [2] to disengage the connection.
- 2) Remove the shafts on both sides [3] while warping the shaft arms inside, and remove the front cover.

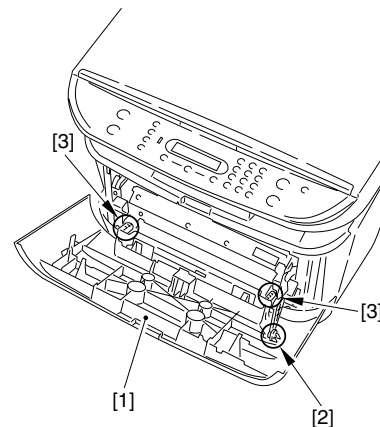

F-3-153

### 3.5.1.3 Removing the right cover

- 1) Remove the 2 screws [1] on the right cover.

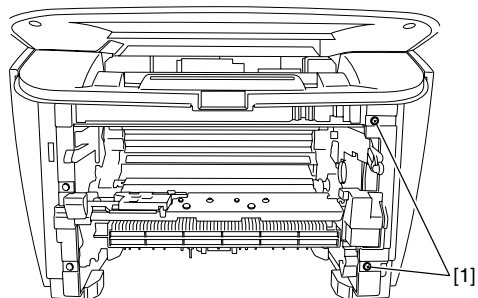

F-3-154

- 2) Remove the right cover [1].  
- 2 screws [2]

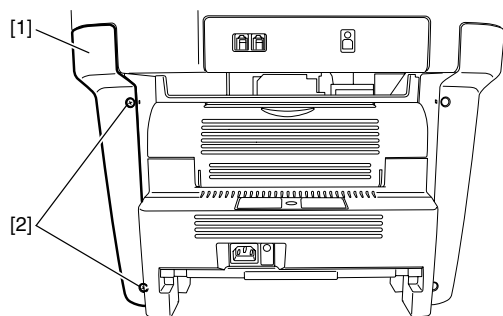

F-3-155

### 3.5.1.4 Removing the left cover

- 1) Remove the 2 screws [1] on the left cover.

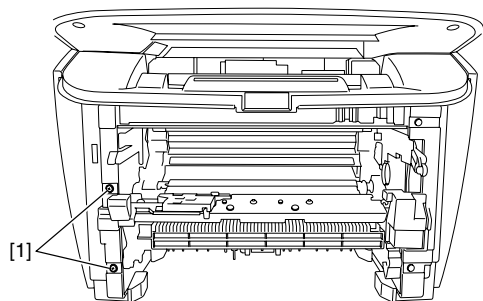

F-3-156

- 2) Remove the left cover [1].  
- 2 screws [2]

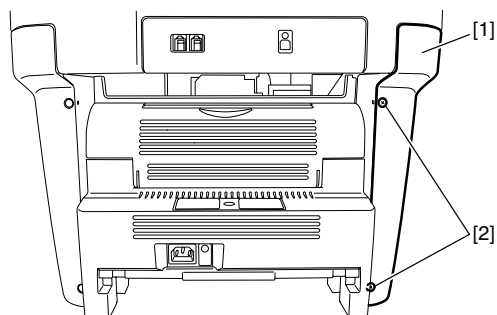

F-3-157

### 3.5.1.5 Removing the rear cover

- 1) Opening the face-up cover [1], and then lower the fixing pressure release levers [2] on both sides and release the pressure.
- 2) Remove the rear cover [3] by sliding it to the rear.  
- 4 screws [4]

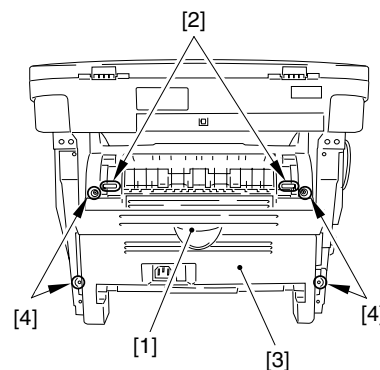

F-3-158

### 3.5.1.6 Removing the Scanner Unit

- 1) Remove the connector [1] and the flat cable [2] on the ECNT board, and remove the screw [3]. (Remove the flat cable from the core.)
- 2) Remove the 2 screws [4] and the 2 pins [5] on the right and left sides.

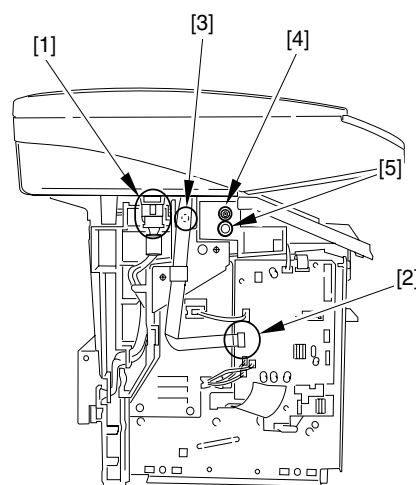

F-3-159

- 3) Remove the scanner unit [1] by sliding it to the rear and lifting it up.  
- 2 screws [2]

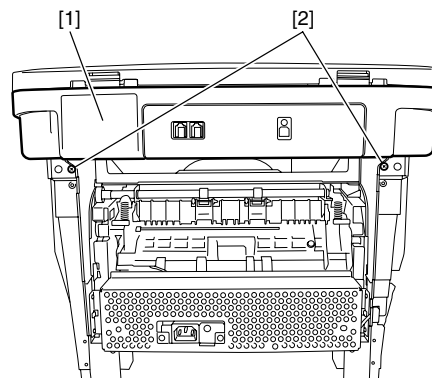

F-3-160

### 3.5.1.7 Removing the top cover

- 1) Free the 2 claws [1], and remove the top cover [2].  
- 2 screws [3]

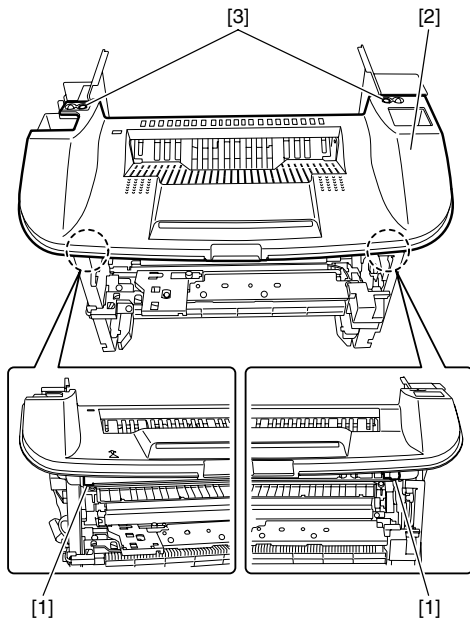

F-3-161

### 3.5.1.8 Removing the Right Frame

- 1) Remove the right frame [1].
- 3 screws [2]

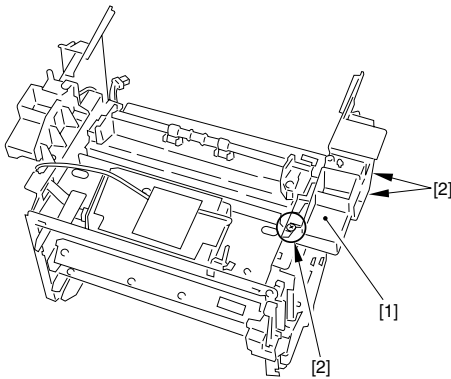

F-3-162

### 3.5.1.9 Removing the Plate

- 1) Remove the plate [1].
- 1 connector [2] on the ECNT board
- 3 screws [3]

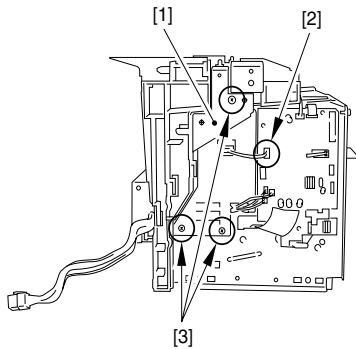

F-3-163

### 3.5.1.10 Removing the Left Frame

- 1) Remove the left frame [1].
- Remove the cable [2] from the guide.
- 3 screws [3]

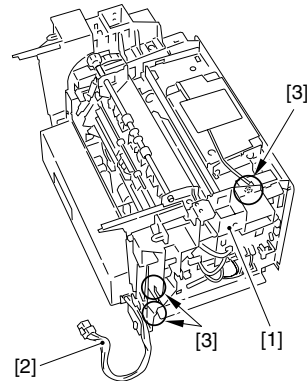

F-3-164

### 3.5.1.11 Removing the Power Supply Shield Plate

- 1) Remove the cable from the cable guide.
- 1 connector [1]

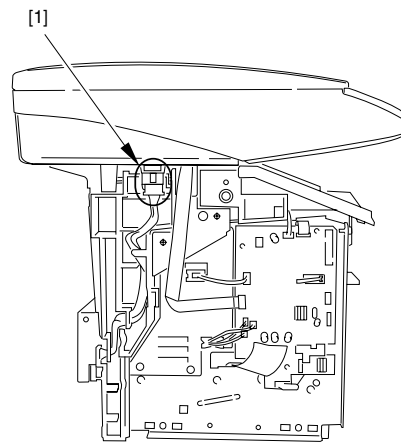

F-3-165

- 2) Remove the power supply shield plate [1].
- 9 screws [2]

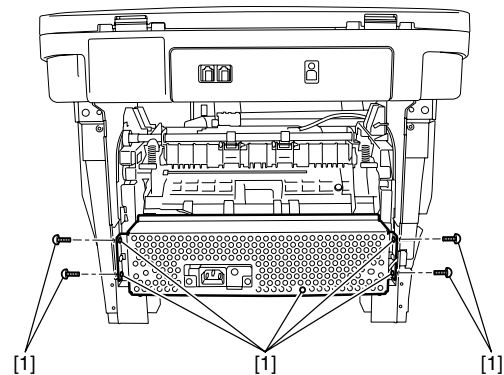

F-3-166

### 3.5.1.12 Removing the Power Supply Assembly

- 1) Remove the 3 screws [1]. (The external cover is omitted from the illustration below to show the instructions clearly.)
- 2) Remove the four connectors [2] as well as the flat cable [3] on the ECNT board.



After having removed the flat cable [3], store it inside the unit to protect it from damage.

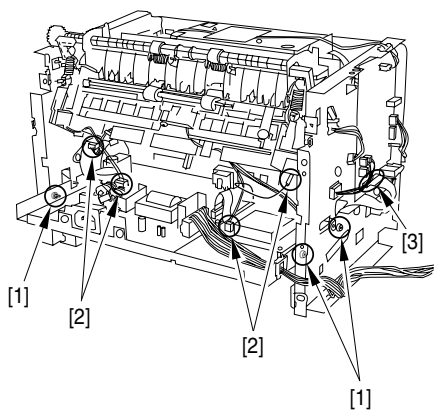

F-3-167

3) As you remove the bosses on both sides [1], lower the front part of the power supply assembly [2]. Then pull it to remove the power supply assembly.

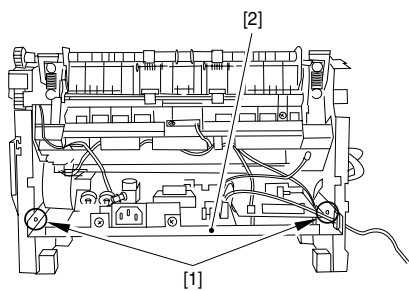

F-3-168

### 3.5.1.13 Removing the Gear Unit

1) Remove the drive plate (small) [1].  
- 2 screws [2]

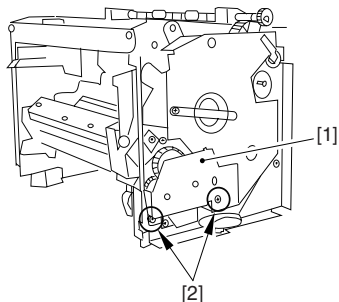

F-3-169

2) Remove the 2 gears [1].  
3) While freeing the claw, detach the gear unit [2].

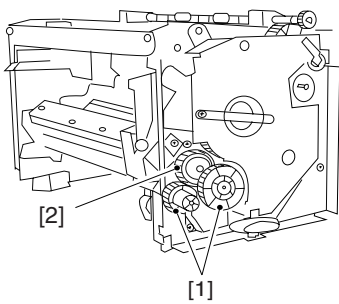

F-3-170

### 3.5.1.14 Removing the Tooth-Missing Gear

1) Remove the gear support [1].  
- 2 screws [2]

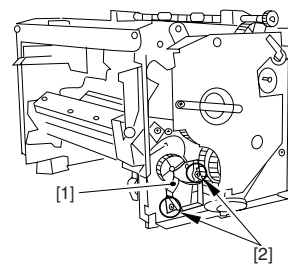

F-3-171

2) Remove the spring [1].  
3) While freeing the claw, detach the tooth-missing gear [2].

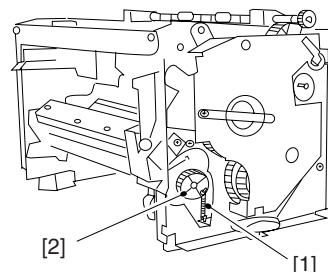

F-3-172

## 3.5.2 Cassette Pickup Solenoid

### 3.5.2.1 Removing the Cassette

1) Remove the cassette by holding the cassette handle.

### 3.5.2.2 Removing the front cover

1) Open the front cover [1] and remove the arm claws [2] to disengage the connection.  
2) Remove the shafts on both sides [3] while warping the shaft arms inside, and remove the front cover.

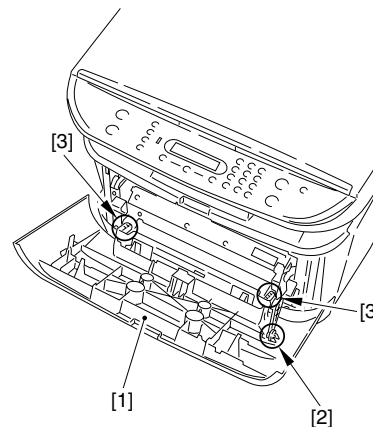

F-3-173

### 3.5.2.3 Removing the right cover

1) Remove the 2 screws [1] on the right cover.

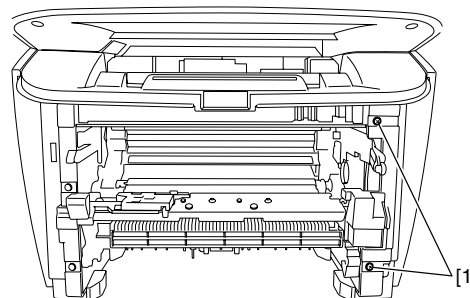

F-3-174

2) Remove the right cover [1].

- 2 screws [2]

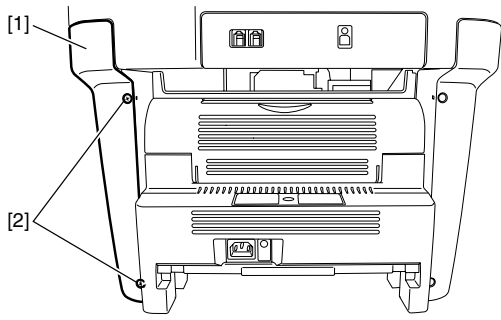

F-3-175

### 3.5.2.4 Removing the left cover

1) Remove the 2 screws [1] on the left cover.

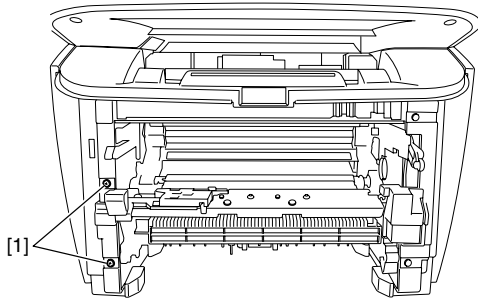

F-3-176

2) Remove the left cover [1].  
- 2 screws [2]

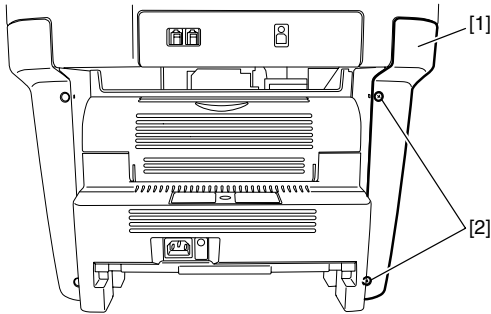

F-3-177

### 3.5.2.5 Removing the rear cover

1) Opening the face-up cover [1], and then lower the fixing pressure release levers [2] on both sides and release the pressure.  
2) Remove the rear cover [3] by sliding it to the rear.  
- 4 screws [4]

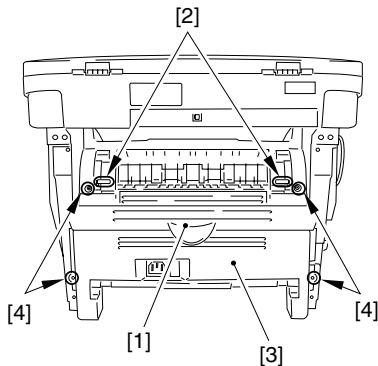

F-3-178

### 3.5.2.6 Removing the Scanner Unit

1) Remove the connector [1] and the flat cable [2] on the ECNT board, and

remove the screw [3]. (Remove the flat cable from the core.)  
2) Remove the 2 screws [4] and the 2 pins [5] on the right and left sides.

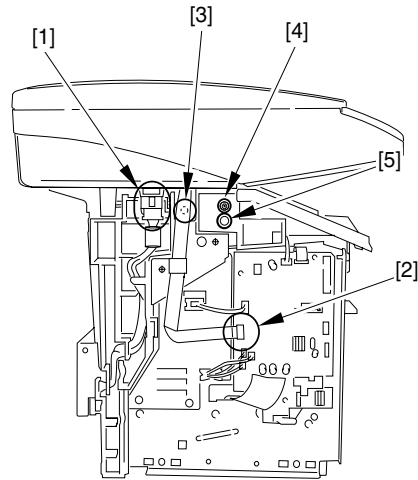

F-3-179

3) Remove the scanner unit [1] by sliding it to the rear and lifting it up.  
- 2 screws [2]

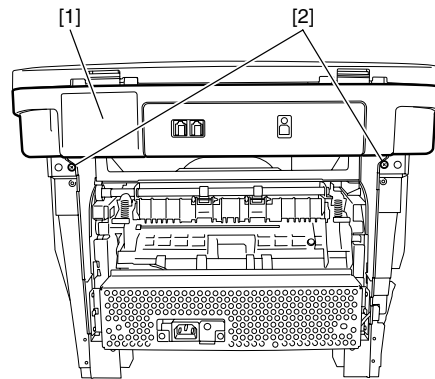

F-3-180

### 3.5.2.7 Removing the top cover

1) Free the 2 claws [1], and remove the top cover [2].  
- 2 screws [3]

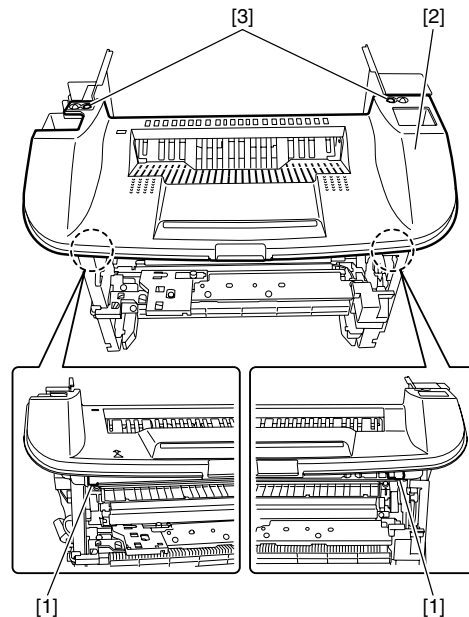

F-3-181



### 3.5.2.8 Removing the Right Frame

- 1) Remove the right frame [1].
- 3 screws [2]

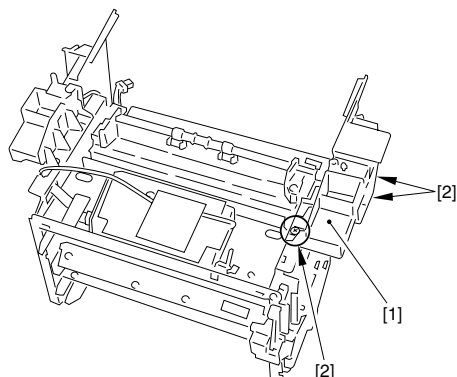

F-3-182

### 3.5.2.9 Removing the Plate

- 1) Remove the plate [1].
- 1 connector [2] on the ECNT board
- 3 screws [3]

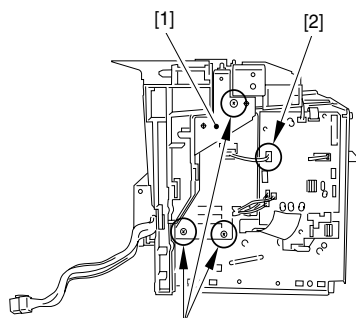

F-3-183

### 3.5.2.10 Removing the Left Frame

- 1) Remove the left frame [1].
- Remove the cable [2] from the guide.
- 3 screws [3]

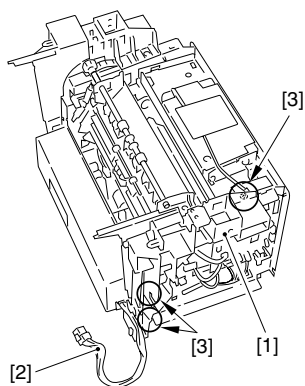

F-3-184

### 3.5.2.11 Removing the Power Supply Shield Plate

- 1) Remove the cable from the cable guide.
- 1 connector [1]

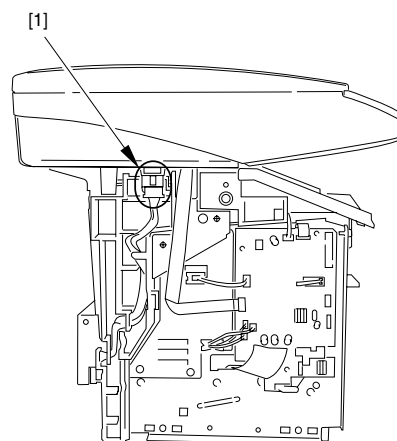

F-3-185

- 2) Remove the power supply shield plate [1].
- 9 screws [2]

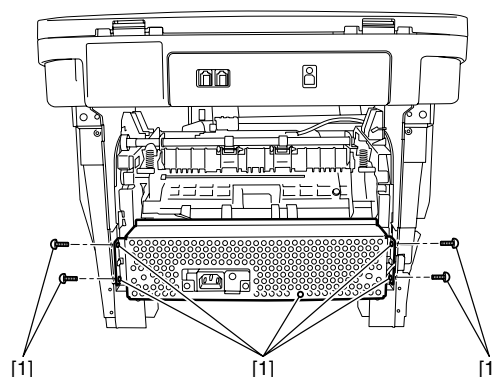

F-3-186

### 3.5.2.12 Removing the Power Supply Assembly

- 1) Remove the 3 screws [1]. (The external cover is omitted from the illustration below to show the instructions clearly.)
- 2) Remove the four connectors [2] as well as the flat cable [3] on the ECNT board.



After having removed the flat cable [3], store it inside the unit to protect it from damage.

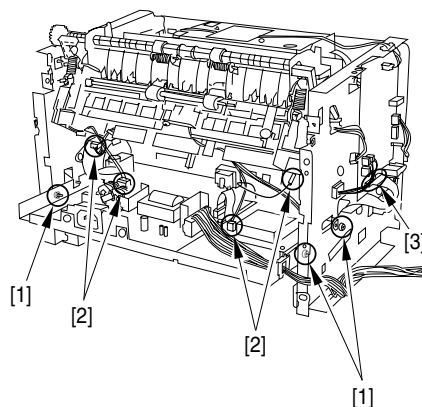

F-3-187

- 3) As you remove the bosses on both sides [1], lower the front part of the power supply assembly [2]. Then pull it to remove the power supply assembly.

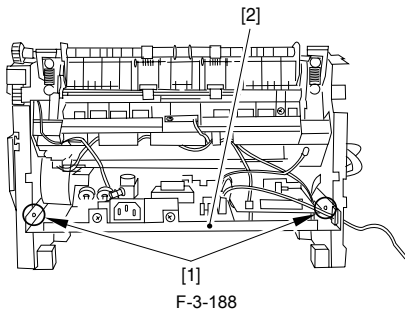

- 2 claws [2]

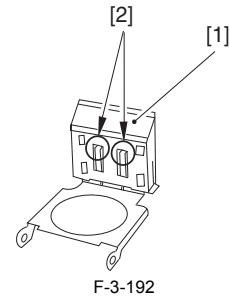

### 3.5.2.13 Removing the Cassette Pickup Solenoid

- 1) Place the main unit down on its front face (so that the interior of the main unit is easily visible).
  - 2) Remove the connector [1] on the ECNT board and take out the cable from the cable guide.
  - 3) Remove the cassette pickup solenoid [2] (behind the main motor).
- 1 screw [3]

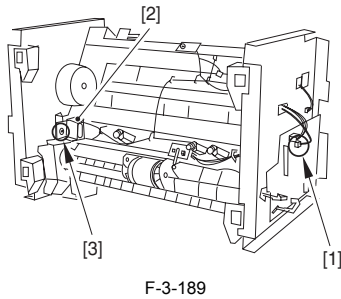

### 3.5.3 Cassette Separation Pad

#### 3.5.3.1 Removing the Cassette

- 1) Remove the cassette by holding the cassette handle.

#### 3.5.3.2 Removing the Rear of the Cassette

- 1) Lift the rear of the cassette, and separate the rear from the front.

#### 3.5.3.3 Removing the Cassette Separation Pad

- 1) Remove the shafts [1] on both sides of the lifting plate. Remove the lifting plate [3] while watching the lifting plate spring [2] carefully.

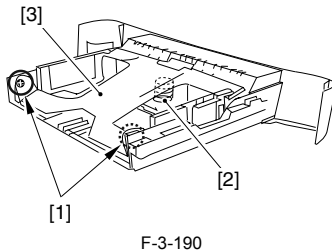

- 2) Remove the 2 claws [1] on both sides of the cassette separation pad and lift it up while watching the lifting plate spring [2] carefully. Ensure that the separation pad spring does not get lost.
- 3) Remove both the plate and the cassette separation pad [3] by sliding them to the left.

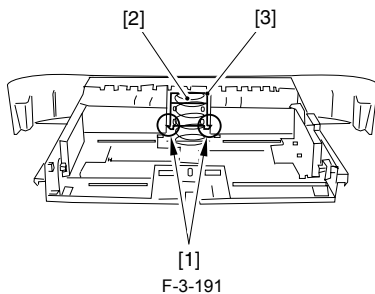

- 4) Remove the cassette separation pad [1] by sliding it upward.

### 3.5.4 Paper Feed Roller

#### 3.5.4.1 Removing the Cassette

- 1) Remove the cassette by holding the cassette handle.

#### 3.5.4.2 Removing the front cover

- 1) Open the front cover [1] and remove the arm claws [2] to disengage the connection.
- 2) Remove the shafts on both sides [3] while warping the shaft arms inside, and remove the front cover.

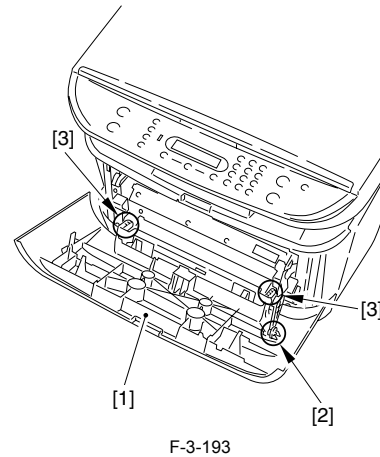

#### 3.5.4.3 Removing the right cover

- 1) Remove the 2 screws [1] on the right cover.

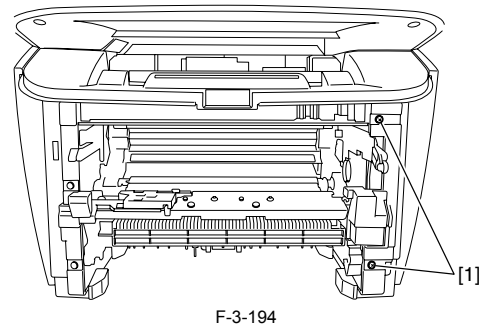

- 2) Remove the right cover [1].
- 2 screws [2]

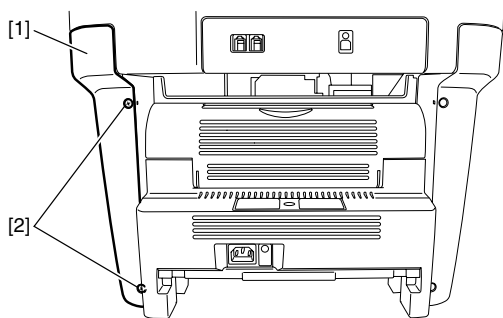

F-3-195

### 3.5.4.4 Removing the left cover

1) Remove the 2 screws [1] on the left cover.

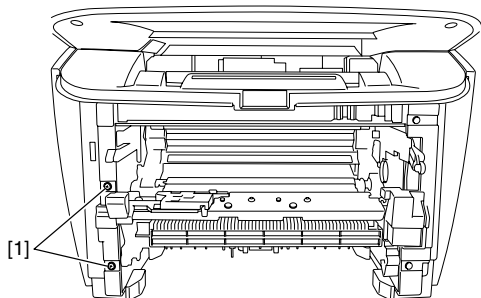

F-3-196

2) Remove the left cover [1].  
- 2 screws [2]

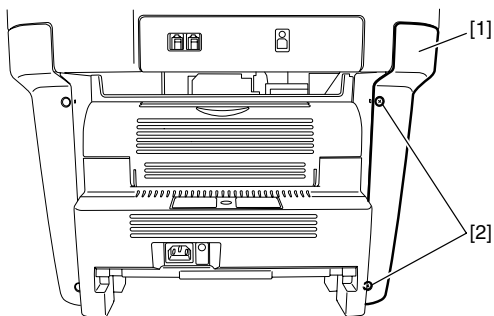

F-3-197

### 3.5.4.5 Removing the rear cover

1) Opening the face-up cover [1], and lower the fixing pressure release levers [2] on both sides and release the pressure.  
2) Remove the rear cover [3] by sliding it to the rear.  
- 4 screws [4]

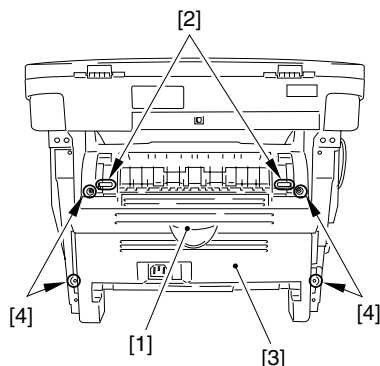

F-3-198

### 3.5.4.6 Removing the Scanner Unit

1) Remove the connector [1] and the flat cable [2] on the ECNT board, and remove the screw [3]. (Remove the flat cable from the core.)

2) Remove the 2 screws [4] and the 2 pins [5] on the right and left sides.

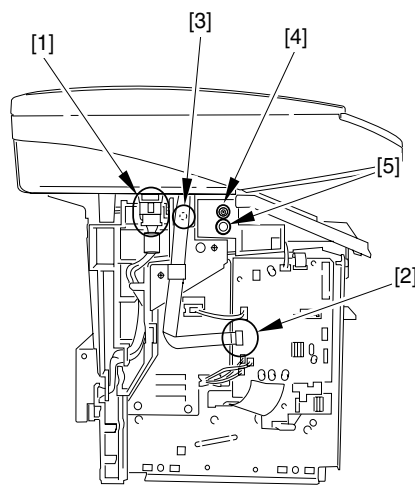

F-3-199

3) Remove the scanner unit [1] by sliding it to the rear and lifting it up.  
- 2 screws [2]

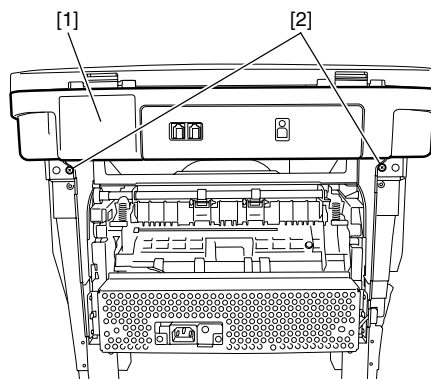

F-3-200

### 3.5.4.7 Removing the top cover

1) Free the 2 claws [1], and remove the top cover [2].  
- 2 screws [3]

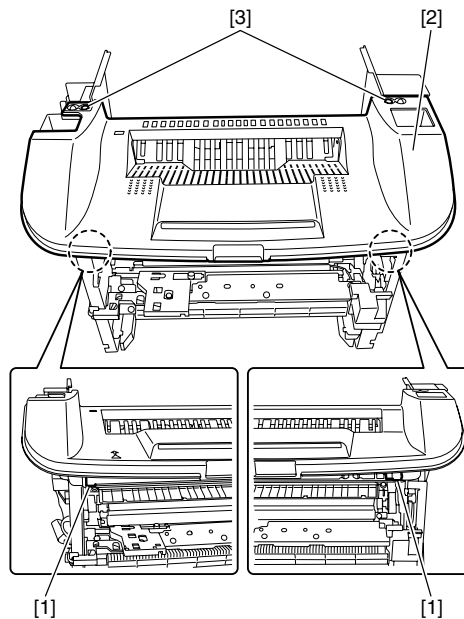

F-3-201

### 3.5.4.8 Removing the Right Frame

1) Remove the right frame [1].

- 3 screws [2]

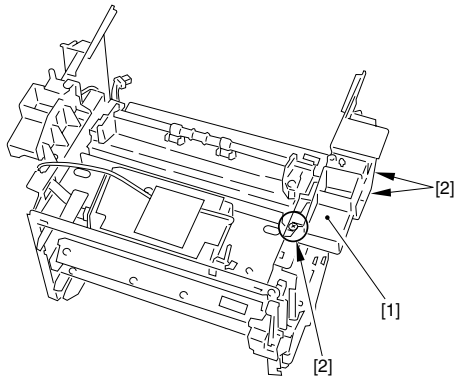

F-3-202

### 3.5.4.9 Removing the Plate

- 1) Remove the plate [1].
- 1 connector [2] on the ECNT board
- 3 screws [3]

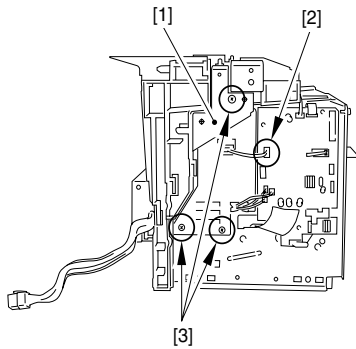

F-3-203

### 3.5.4.10 Removing the Left Frame

- 1) Remove the left frame [1].
- Remove the cable [2] from the guide.
- 3 screws [3]

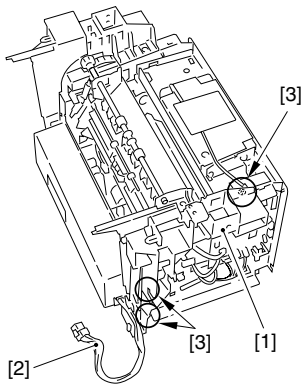

F-3-204

### 3.5.4.11 Removing the Power Supply Shield Plate

- 1) Remove the cable from the cable guide.
- 1 connector [1]

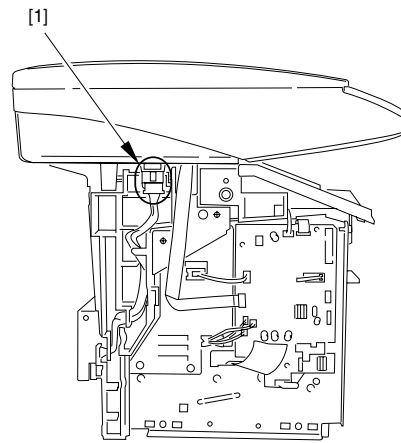

F-3-205

- 2) Remove the power supply shield plate [1].
- 9 screws [2]

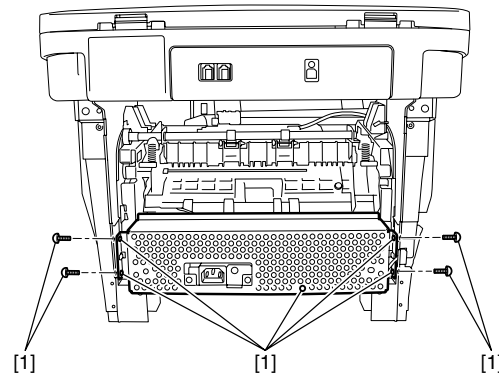

F-3-206

### 3.5.4.12 Removing the Power Supply Assembly

- 1) Remove the 3 screws [1]. (The external cover is omitted from the illustration below to show the instructions clearly.)
- 2) Remove the four connectors [2] as well as the flat cable [3] on the ECNT board.



After having removed the flat cable [3], store it inside the unit to protect it from damage.

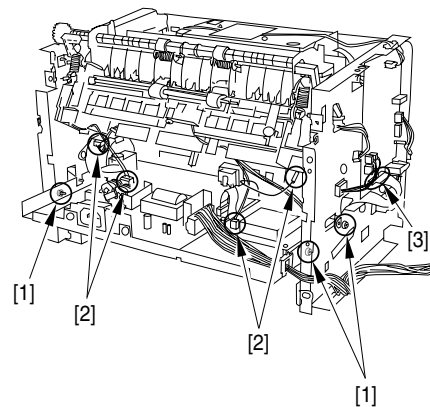

F-3-207

- 3) As you remove the bosses on both sides [1], lower the front part of the power supply assembly [2]. Then pull it to remove the power supply assembly.

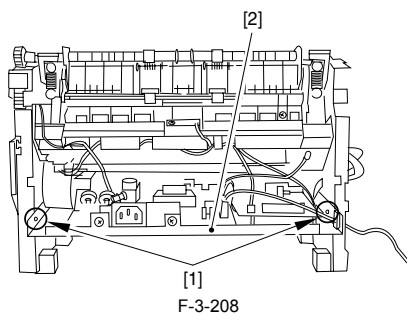

### 3.5.4.13 Removing the Gear Unit

- 1) Remove the drive plate (small) [1].  
- 2 screws [2]

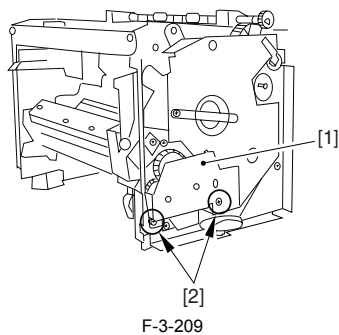

- 2) Remove the 2 gears [1].
- 3) While freeing the claw, detach the gear unit [2].

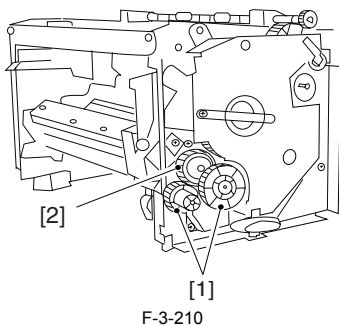

### 3.5.4.14 Removing the Tooth-Missing Gear

- 1) Remove the gear support [1].  
- 2 screws [2]

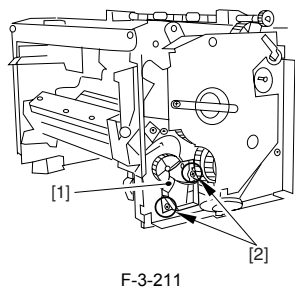

- 2) Remove the spring [1].
- 3) While freeing the claw, detach the tooth-missing gear [2].

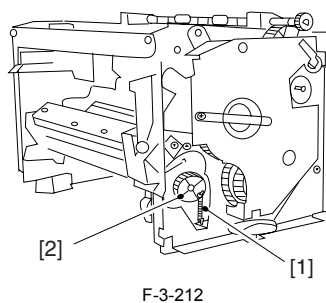

### 3.5.4.15 Removing the Manual Stay

- 1) Release the lower claw [2] of the solenoid cover [1], and remove the solenoid cover.
- 2) Remove the 3 screws [3]. While watching the sensor flag carefully, remove the manual stay [4].

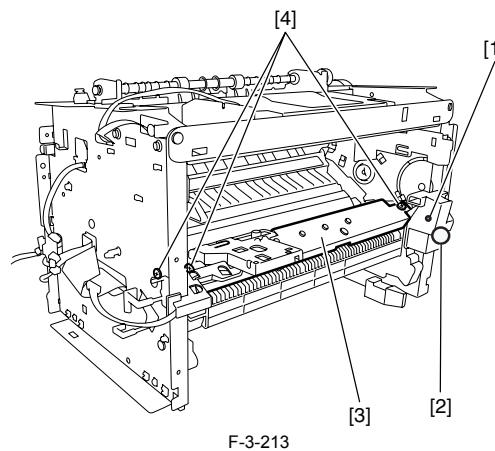

### 3.5.4.16 Removing the Paper Feed Guide

- 1) Remove the feed guide [1].  
- 1 screw [2]

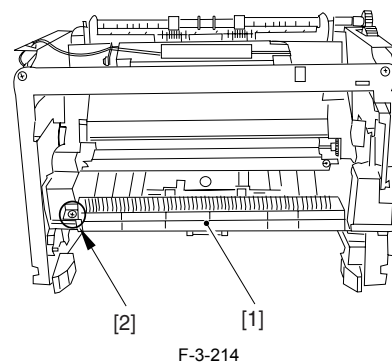

### 3.5.4.17 Removing the Paper Feed Roller

- 1) Lift the left side of the paper feed roller [1], and slide it to detach.

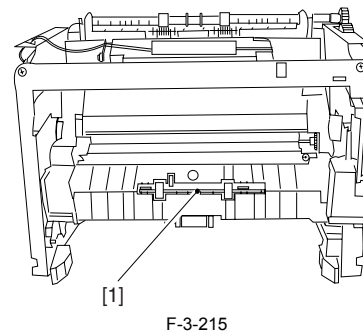

### 3.5.5 Manual Pickup Solenoid

#### 3.5.5.1 Removing the Cassette

- 1) Remove the cassette by holding the cassette handle.

#### 3.5.5.2 Removing the front cover

- 1) Open the front cover [1] and remove the arm claws [2] to disengage the connection.
- 2) Remove the shafts on both sides [3] while warping the shaft arms inside, and remove the front cover.

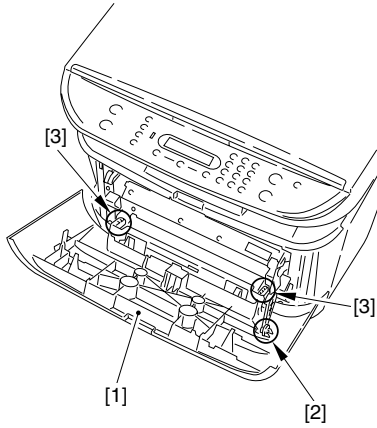

F-3-216

#### 3.5.5.3 Removing the right cover

- 1) Remove the 2 screws [1] on the right cover.

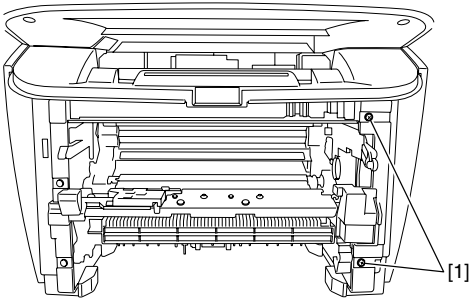

F-3-217

- 2) Remove the right cover [1].  
- 2 screws [2]

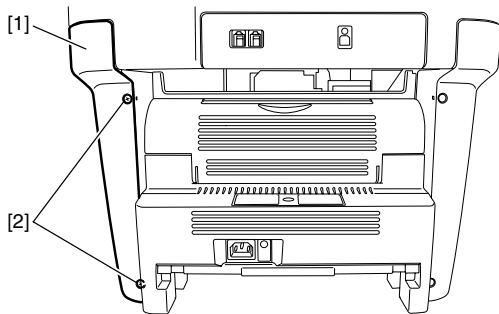

F-3-218

#### 3.5.5.4 Removing the left cover

- 1) Remove the 2 screws [1] on the left cover.

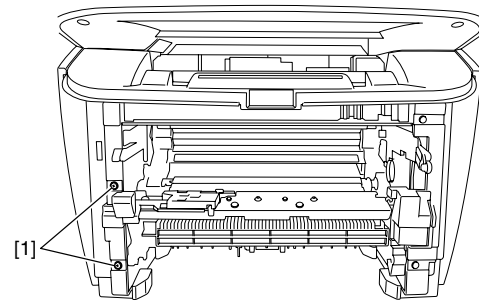

F-3-219

- 2) Remove the left cover [1].  
- 2 screws [2]

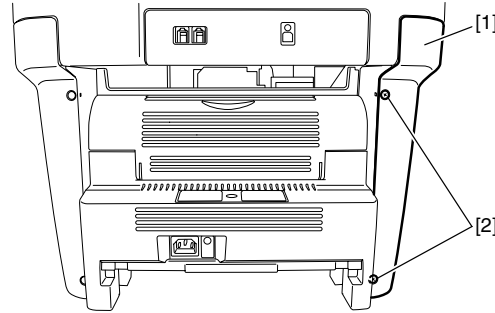

F-3-220

#### 3.5.5.5 Removing the rear cover

- 1) Opening the face-up cover [1], and then lower the fixing pressure release levers [2] on both sides and release the pressure.
- 2) Remove the rear cover [3] by sliding it to the rear.  
- 4 screws [4]

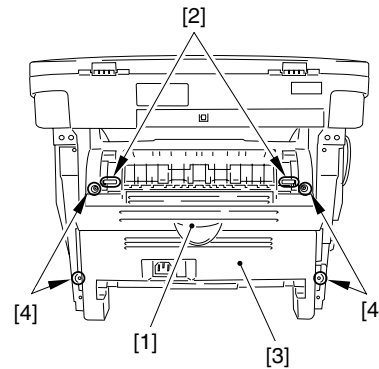

F-3-221

#### 3.5.5.6 Removing the Scanner Unit

- 1) Remove the connector [1] and the flat cable [2] on the ECNT board, and remove the screw [3]. (Remove the flat cable from the core.)
- 2) Remove the 2 screws [4] and the 2 pins [5] on the right and left sides.

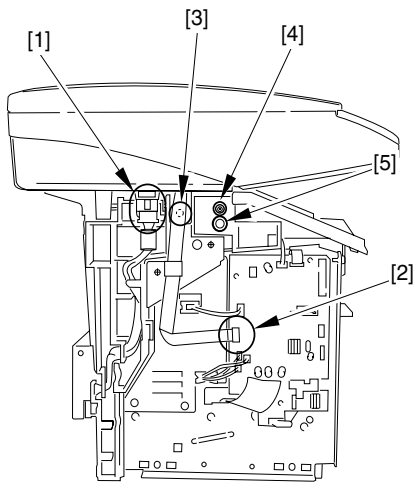

F-3-222

3) Remove the scanner unit [1] by sliding it to the rear and lifting it up.  
- 2 screws [2]

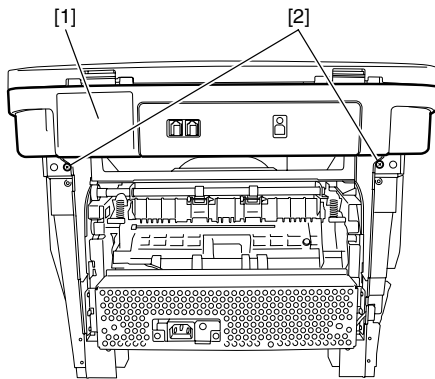

F-3-223

### 3.5.5.7 Removing the top cover

1) Free the 2 claws [1], and remove the top cover [2].  
- 2 screws [3]

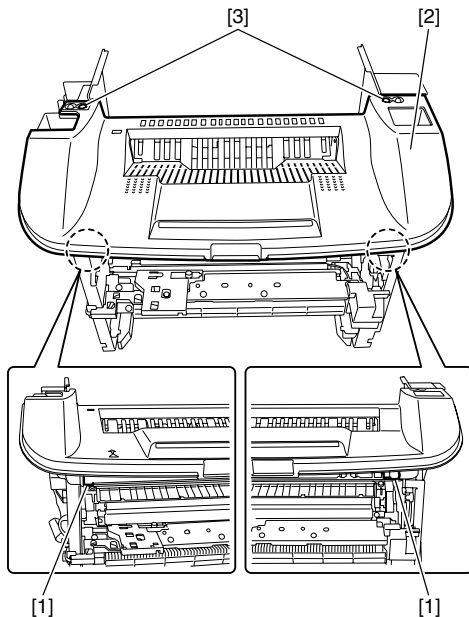

F-3-224

### 3.5.5.8 Removing the Right Frame

1) Remove the right frame [1].

- 3 screws [2]

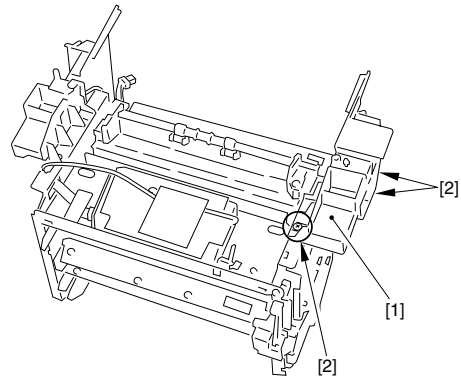

F-3-225

### 3.5.5.9 Removing the Plate

1) Remove the plate [1].  
- 1 connector [2] on the ECNT board  
- 3 screws [3]

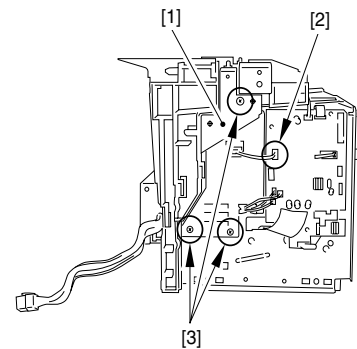

F-3-226

### 3.5.5.10 Removing the Left Frame

1) Remove the left frame [1].  
- Remove the cable [2] from the guide.  
- 3 screws [3]

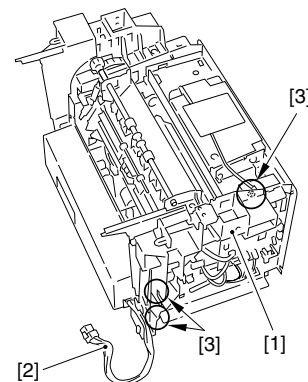

F-3-227

### 3.5.5.11 Removing the Power Supply Shield Plate

1) Remove the cable from the cable guide.  
- 1 connector [1]

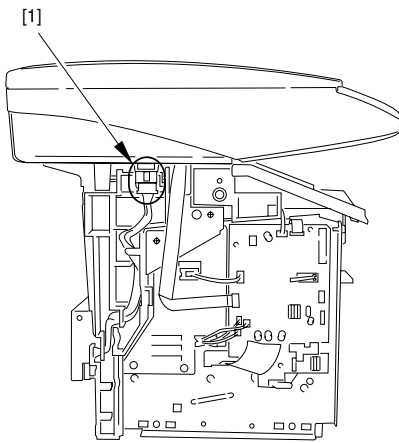

F-3-228

- 2) Remove the power supply shield plate [1].  
- 9 screws [2]

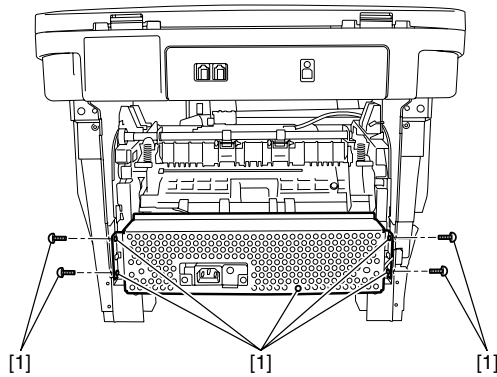

F-3-229

### 3.5.5.12 Removing the Power Supply Assembly

- 1) Remove the 3 screws [1]. (The external cover is omitted from the illustration below to show the instructions clearly.)
- 2) Remove the four connectors [2] as well as the flat cable [3] on the ECNT board.



After having removed the flat cable [3], store it inside the unit to protect it from damage.

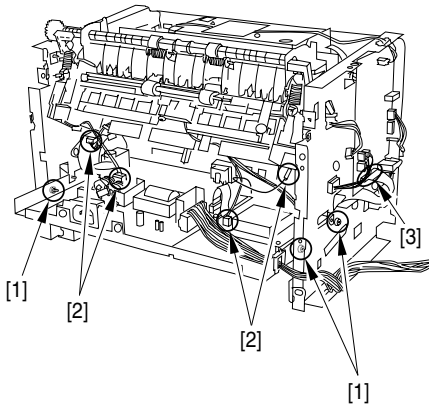

F-3-230

- 3) As you remove the bosses on both sides [1], lower the front part of the power supply assembly [2]. Then pull it to remove the power supply assembly.

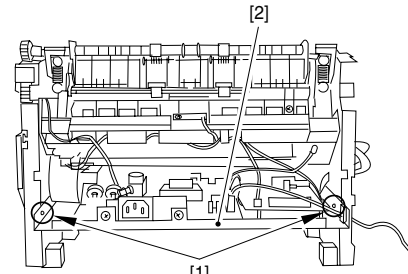

F-3-231

### 3.5.5.13 Removing the Manual Pickup Solenoid

- 1) Turn the main unit over so that the front faces down (and the inside is visible).
- 2) Remove the cable [1] from the cable guide.
- 3) Remove the manual feed solenoid [2].  
- 1 screw [3]

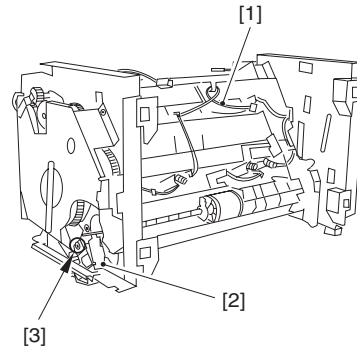

F-3-232

### 3.5.6 Main Motor

#### 3.5.6.1 Removing the Cassette

- 1) Remove the cassette by holding the cassette handle.

#### 3.5.6.2 Removing the front cover

- 1) Open the front cover [1] and remove the arm claws [2] to disengage the connection.
- 2) Remove the shafts on both sides [3] while warping the shaft arms inside, and remove the front cover.

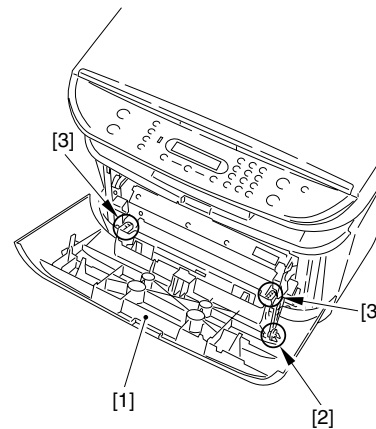

F-3-233

#### 3.5.6.3 Removing the right cover

- 1) Remove the 2 screws [1] on the right cover.



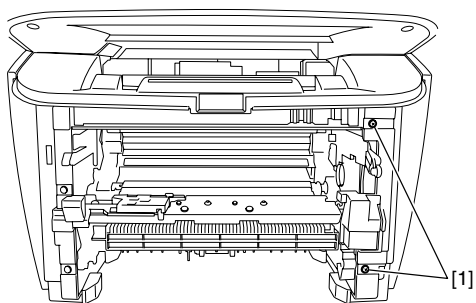

F-3-234

- 2) Remove the right cover [1].  
- 2 screws [2]

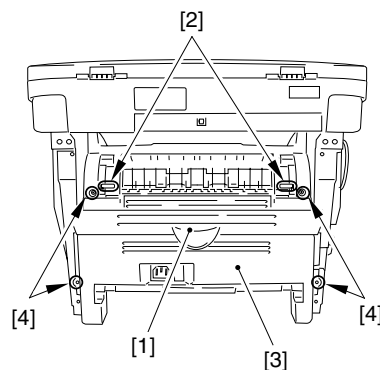

F-3-238

### 3.5.6.6 Removing the Scanner Unit

- 1) Remove the connector [1] and the flat cable [2] on the ECNT board, and remove the screw [3]. (Remove the flat cable from the core.)  
2) Remove the 2 screws [4] and the 2 pins [5] on the right and left sides.

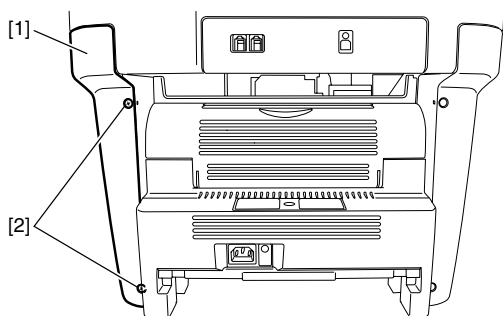

F-3-235

### 3.5.6.4 Removing the left cover

- 1) Remove the 2 screws [1] on the left cover.

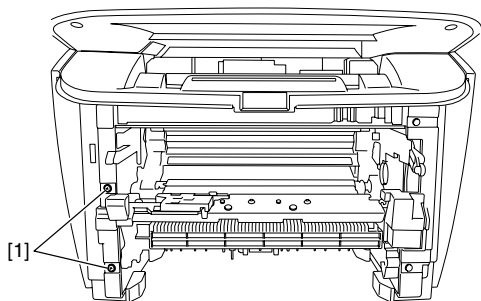

F-3-236

- 2) Remove the left cover [1].  
- 2 screws [2]

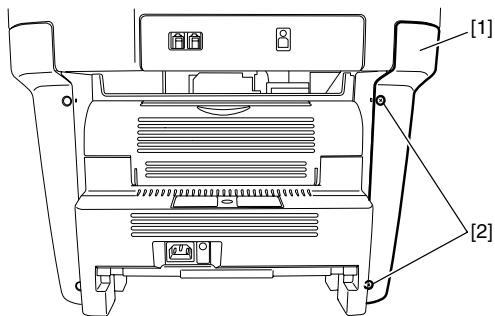

F-3-237

### 3.5.6.5 Removing the rear cover

- 1) Opening the face-up cover [1], and then lower the fixing pressure release levers [2] on both sides and release the pressure.  
2) Remove the rear cover [3] by sliding it to the rear.  
- 4 screws [4]

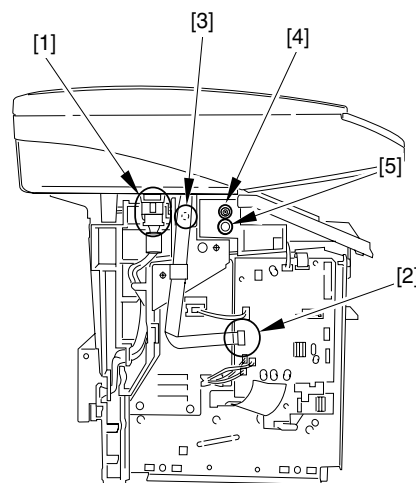

F-3-239

- 3) Remove the scanner unit [1] by sliding it to the rear and lifting it up.  
- 2 screws [2]

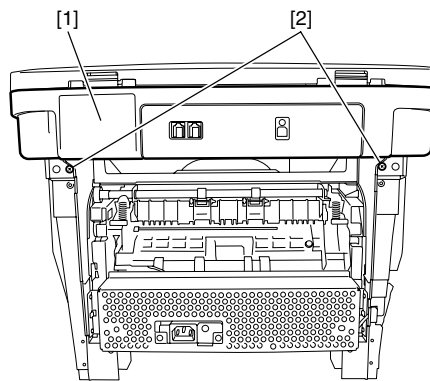

F-3-240

### 3.5.6.7 Removing the top cover

- 1) Free the 2 claws [1], and remove the top cover [2].  
- 2 screws [3]

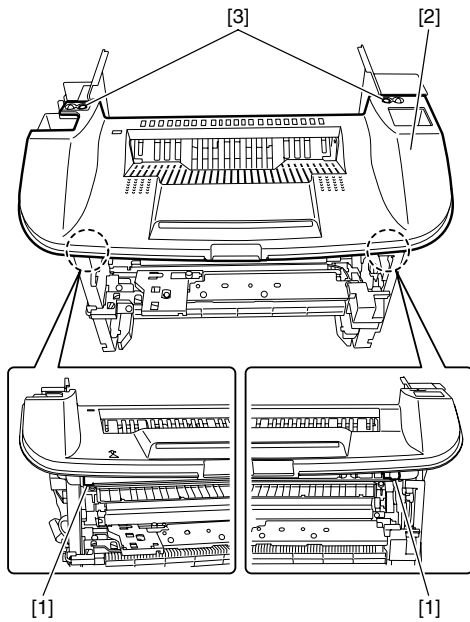

F-3-241

### 3.5.6.8 Removing the Right Frame

- 1) Remove the right frame [1].
- 3 screws [2]

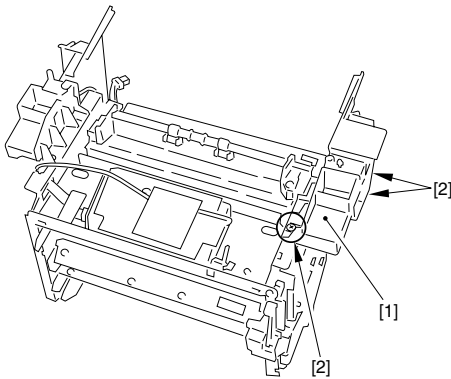

F-3-242

### 3.5.6.9 Removing the Plate

- 1) Remove the plate [1].
- 1 connector [2] on the ECNT board
- 3 screws [3]

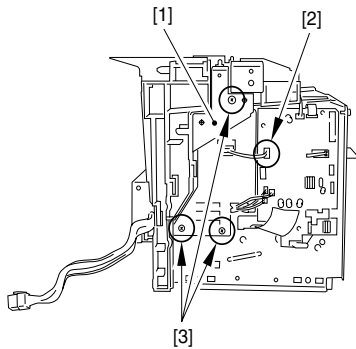

F-3-243

### 3.5.6.10 Removing the Left Frame

- 1) Remove the left frame [1].
- Remove the cable [2] from the guide.
- 3 screws [3]

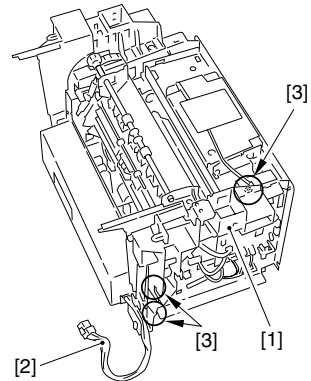

F-3-244

### 3.5.6.11 Removing the Power Supply Shield Plate

- 1) Remove the cable from the cable guide.
- 1 connector [1]

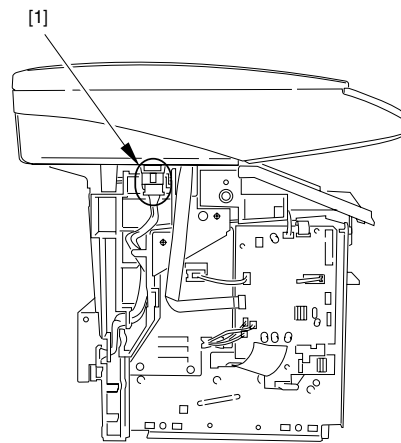

F-3-245

- 2) Remove the power supply shield plate [1].
- 9 screws [2]

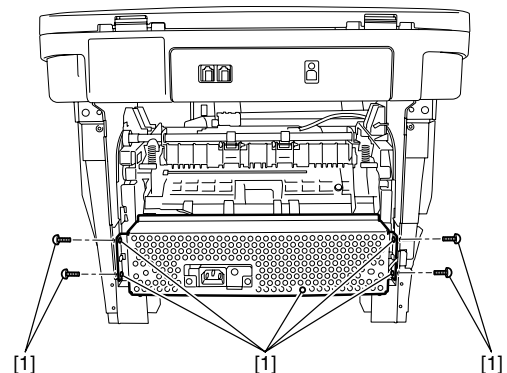

F-3-246

### 3.5.6.12 Removing the Power Supply Assembly

- 1) Remove the 3 screws [1]. (The external cover is omitted from the illustration below to show the instructions clearly.)
- 2) Remove the four connectors [2] as well as the flat cable [3] on the ECNT board.



After having removed the flat cable [3], store it inside the unit to protect it from damage.

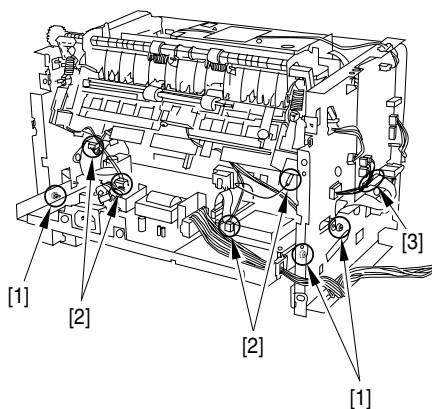

F-3-247

- 3) As you remove the bosses on both sides [1], lower the front part of the power supply assembly [2]. Then pull it to remove the power supply assembly.

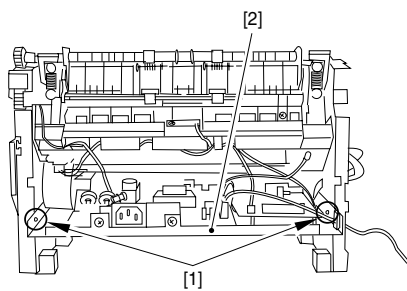

F-3-248

### 3.5.6.13 Removing the Main Motor

- 1) Place the main unit down on its front face (so that the interior of the main unit is easily visible).
- 2) Remove the main motor [1].  
- 2 screws [2]

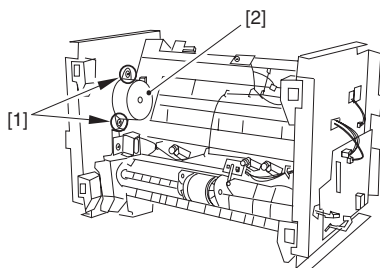

F-3-249

## 3.5.7 Gear Unit

### 3.5.7.1 Removing the Cassette

- 1) Remove the cassette by holding the cassette handle.

### 3.5.7.2 Removing the front cover

- 1) Open the front cover [1] and remove the arm claws [2] to disengage the connection.
- 2) Remove the shafts on both sides [3] while warping the shaft arms inside, and remove the front cover.

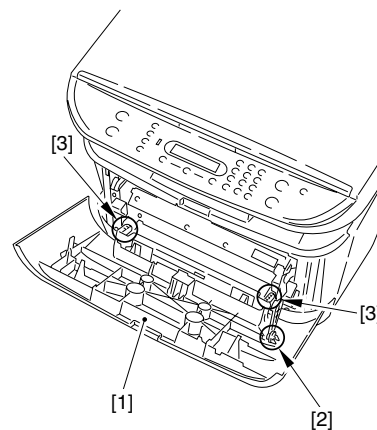

F-3-250

### 3.5.7.3 Removing the right cover

- 1) Remove the 2 screws [1] on the right cover.

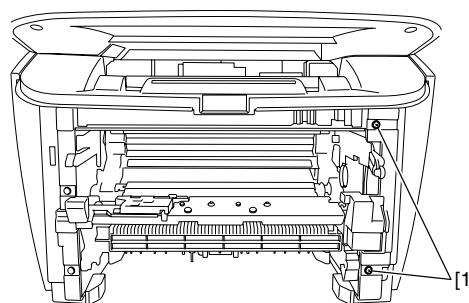

F-3-251

- 2) Remove the right cover [1].  
- 2 screws [2]

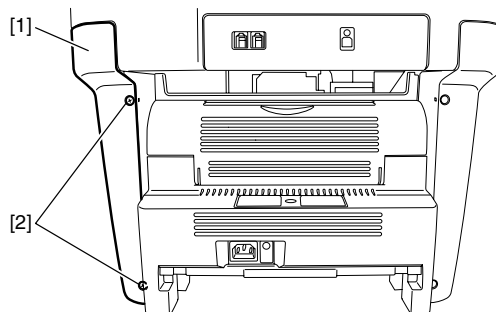

F-3-252

### 3.5.7.4 Removing the Gear Unit

- 1) Remove the drive plate (small) [1].  
- 2 screws [2]

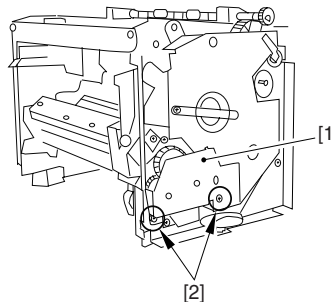

F-3-253

- 2) Remove the 2 gears [1].
- 3) While freeing the claw, detach the gear unit [2].

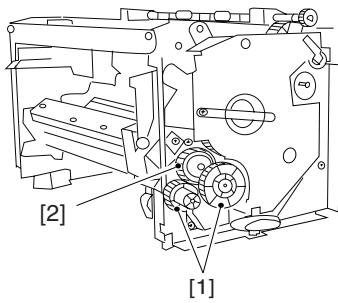

F-3-254

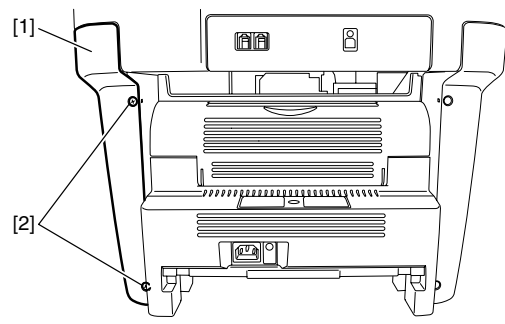

F-3-257

### 3.6 FIXING SYSTEM

#### 3.6.1 Fixing Film Unit

##### 3.6.1.1 Removing the Cassette

1) Remove the cassette by holding the cassette handle.

##### 3.6.1.2 Removing the front cover

- 1) Open the front cover [1] and remove the arm claws [2] to disengage the connection.
- 2) Remove the shafts on both sides [3] while warping the shaft arms inside, and remove the front cover.

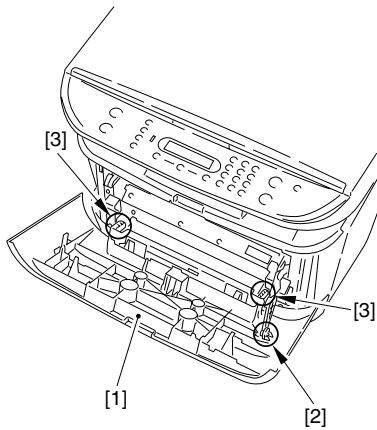

F-3-255

##### 3.6.1.4 Removing the left cover

1) Remove the 2 screws [1] on the left cover.

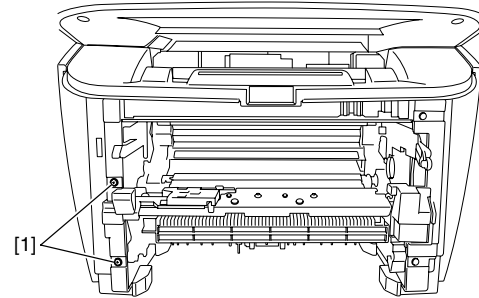

F-3-258

2) Remove the left cover [1].  
- 2 screws [2]

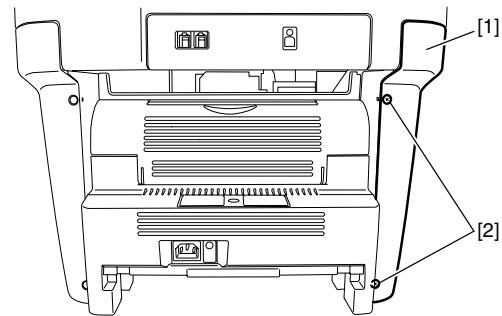

F-3-259

##### 3.6.1.3 Removing the right cover

1) Remove the 2 screws [1] on the right cover.

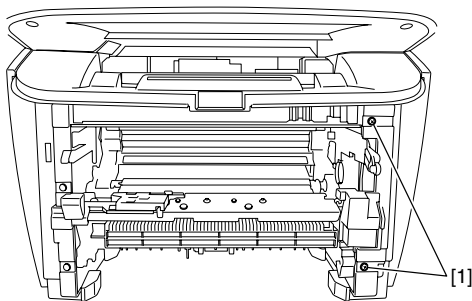

F-3-256

2) Remove the right cover [1].  
- 2 screws [2]

##### 3.6.1.5 Removing the rear cover

- 1) Opening the face-up cover [1], and then lower the fixing pressure release levers [2] on both sides and release the pressure.
- 2) Remove the rear cover [3] by sliding it to the rear.  
- 4 screws [4]

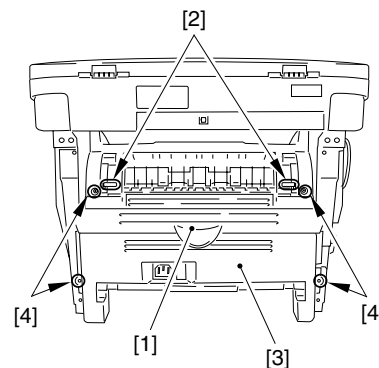

F-3-260

##### 3.6.1.6 Removing the Scanner Unit

1) Remove the connector [1] and the flat cable [2] on the ECNT board, and remove the screw [3]. (Remove the flat cable from the core.)

2) Remove the 2 screws [4] and the 2 pins [5] on the right and left sides.

- 3 screws [2]

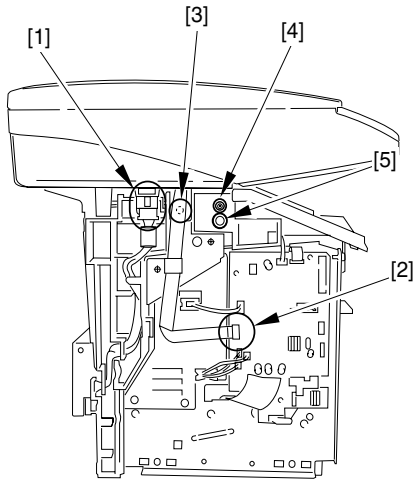

F-3-261

3) Remove the scanner unit [1] by sliding it to the rear and lifting it up.  
- 2 screws [2]

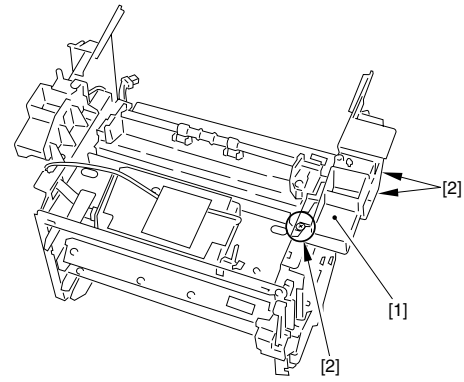

F-3-264

### 3.6.1.9 Removing the Plate

1) Remove the plate [1].  
- 1 connector [2] on the ECNT board  
- 3 screws [3]

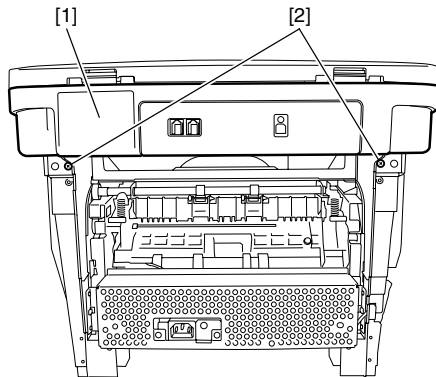

F-3-262

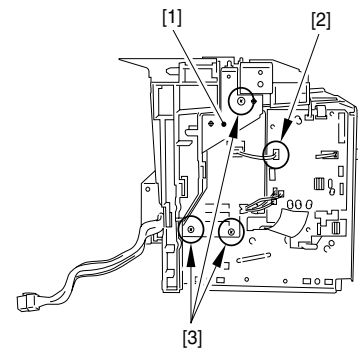

F-3-265

### 3.6.1.7 Removing the top cover

1) Free the 2 claws [1], and remove the top cover [2].  
- 2 screws [3]

### 3.6.1.10 Removing the Left Frame

1) Remove the left frame [1].  
- Remove the cable [2] from the guide.  
- 3 screws [3]

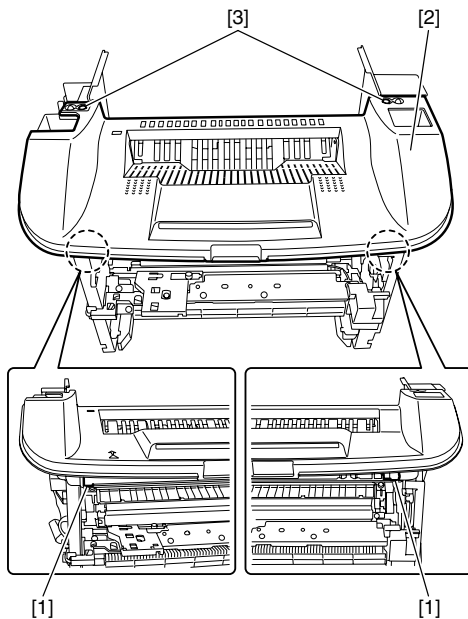

F-3-263

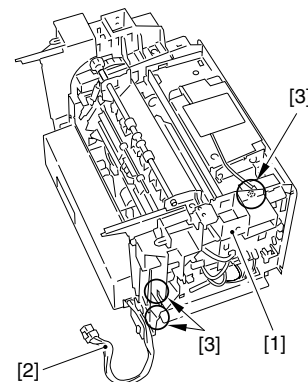

F-3-266

### 3.6.1.11 Removing the Power Supply Shield Plate

1) Remove the cable from the cable guide.  
- 1 connector [1]

### 3.6.1.8 Removing the Right Frame

1) Remove the right frame [1].

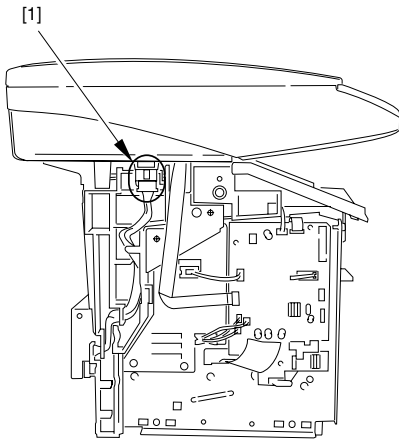

F-3-267

- 2) Remove the power supply shield plate [1].  
- 9 screws [2]

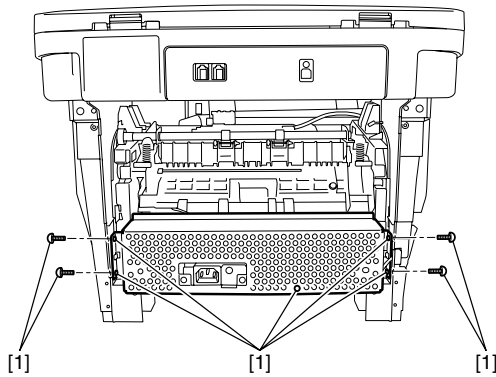

F-3-268

### 3.6.1.12 Removing the Fixing Film Unit

- 1) Remove the fixing cover [1].  
- 2 screws [2]

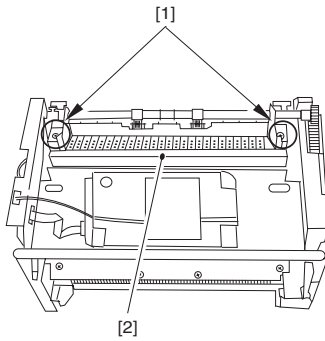

F-3-269

- 2) Remove the fixing entrance guide [1] by sliding it to the left and right.  
- 2 screws [2]

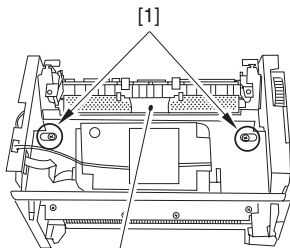

F-3-270

- 3) Disengage the connector [1] of the power supply board.  
4) Remove the grounding springs and the pressure springs [2] on both sides.

- 5) Remove the pressure plates [3] on both sides.

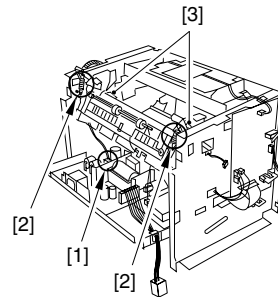

F-3-271

- 6) While holding the left and right frames [2] of the Fixing film unit [1], lift it up at an angle and remove it.

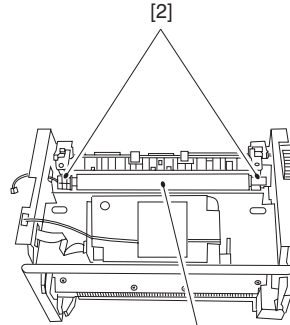

F-3-272

### 3.6.2 Fixing Pressure Roller

#### 3.6.2.1 Removing the Cassette

- 1) Remove the cassette by holding the cassette handle.

#### 3.6.2.2 Removing the front cover

- 1) Open the front cover [1] and remove the arm claws [2] to disengage the connection.  
2) Remove the shafts on both sides [3] while warping the shaft arms inside, and remove the front cover.

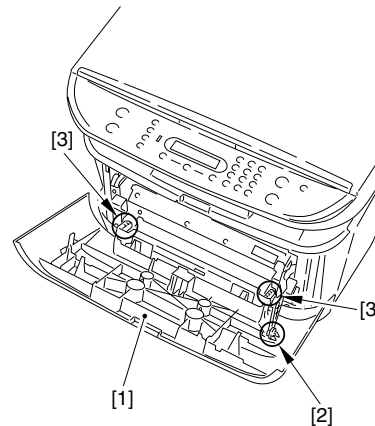

F-3-273

#### 3.6.2.3 Removing the right cover

- 1) Remove the 2 screws [1] on the right cover.

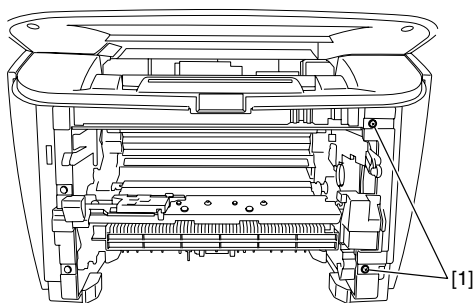

F-3-274

- 2) Remove the right cover [1].  
- 2 screws [2]

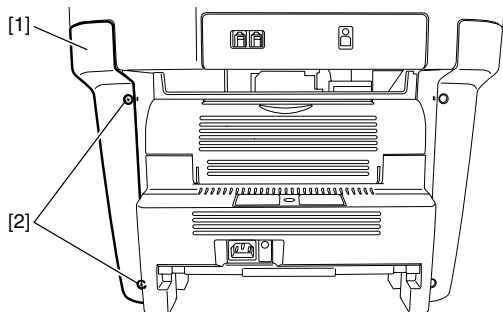

F-3-275

### 3.6.2.4 Removing the left cover

- 1) Remove the 2 screws [1] on the left cover.

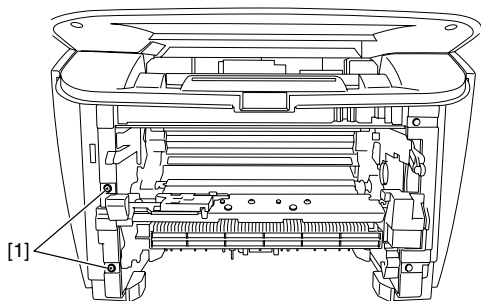

F-3-276

- 2) Remove the left cover [1].  
- 2 screws [2]

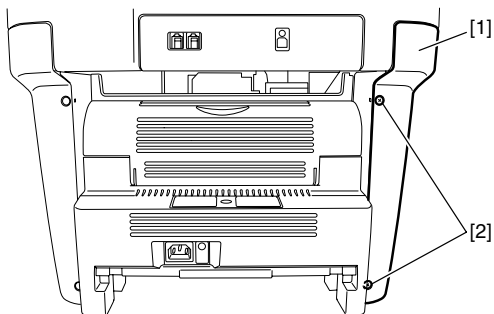

F-3-277

### 3.6.2.5 Removing the rear cover

- 1) Opening the face-up cover [1], and then lower the fixing pressure release levers [2] on both sides and release the pressure.  
2) Remove the rear cover [3] by sliding it to the rear.  
- 4 screws [4]

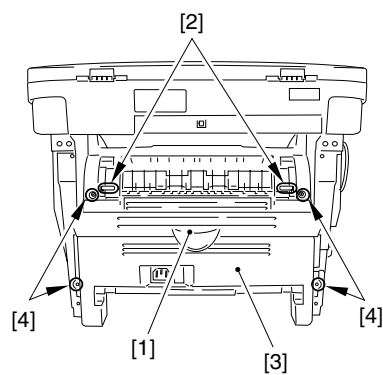

F-3-278

### 3.6.2.6 Removing the Scanner Unit

- 1) Remove the connector [1] and the flat cable [2] on the ECNT board, and remove the screw [3]. (Remove the flat cable from the core.)  
2) Remove the 2 screws [4] and the 2 pins [5] on the right and left sides.

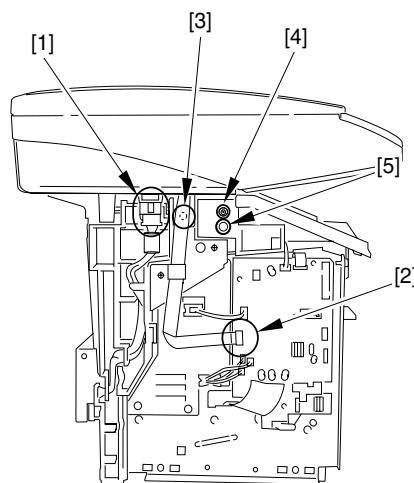

F-3-279

- 3) Remove the scanner unit [1] by sliding it to the rear and lifting it up.  
- 2 screws [2]

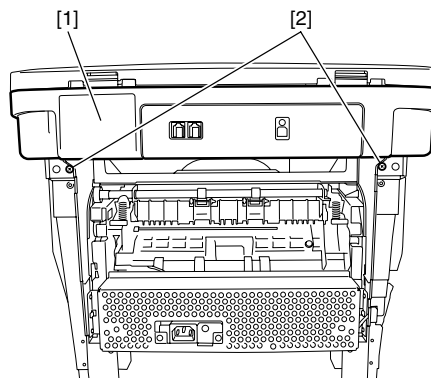

F-3-280

### 3.6.2.7 Removing the top cover

- 1) Free the 2 claws [1], and remove the top cover [2].  
- 2 screws [3]

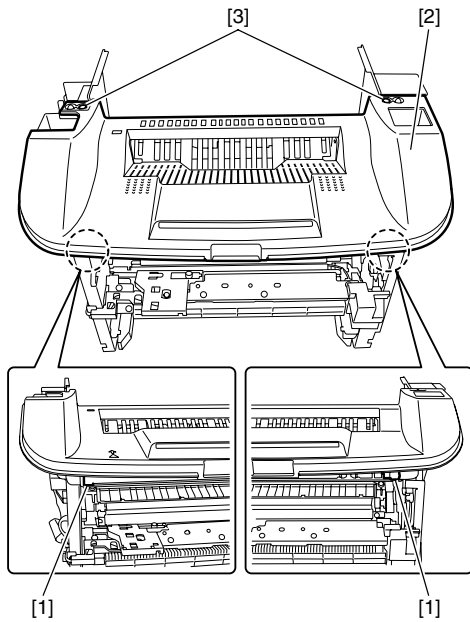

F-3-281

### 3.6.2.8 Removing the Right Frame

- 1) Remove the right frame [1].
- 3 screws [2]

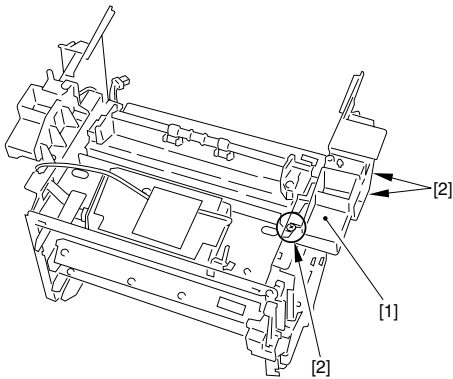

F-3-282

### 3.6.2.9 Removing the Plate

- 1) Remove the plate [1].
- 1 connector [2] on the ECNT board
  - 3 screws [3]

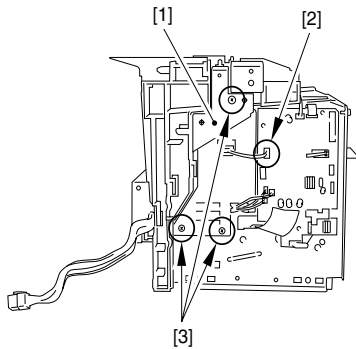

F-3-283

### 3.6.2.10 Removing the Left Frame

- 1) Remove the left frame [1].
- Remove the cable [2] from the guide.
  - 3 screws [3]

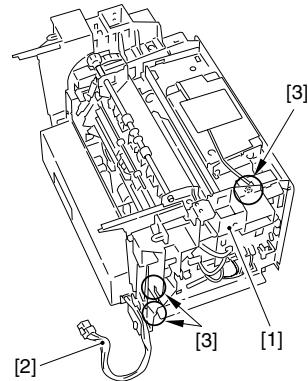

F-3-284

### 3.6.2.11 Removing the Power Supply Shield Plate

- 1) Remove the cable from the cable guide.
- 1 connector [1]

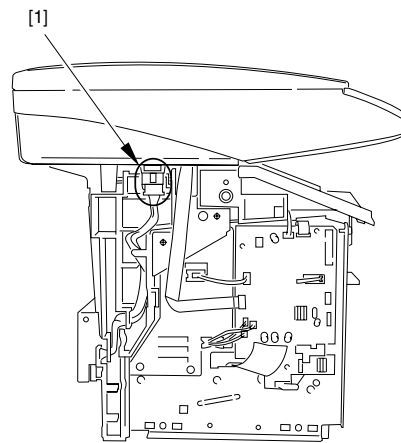

F-3-285

- 2) Remove the power supply shield plate [1].
- 9 screws [2]

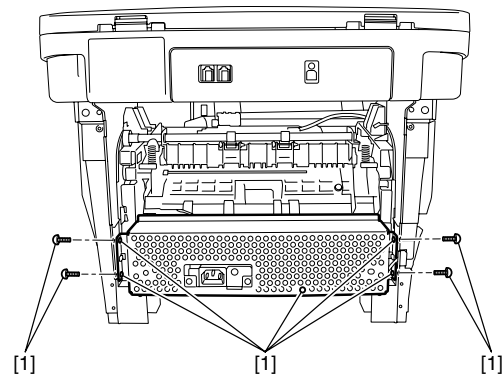

F-3-286

### 3.6.2.12 Removing the Fixing Film Unit

- 1) Remove the fixing cover [1].
- 2 screws [2]



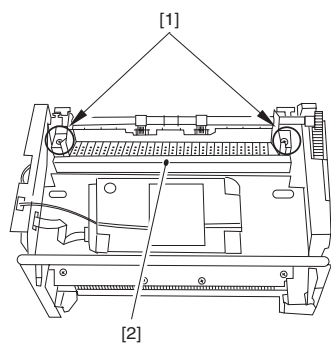

F-3-287

- 2) Remove the fixing entrance guide [1] by sliding it to the left and right.  
- 2 screws [2]

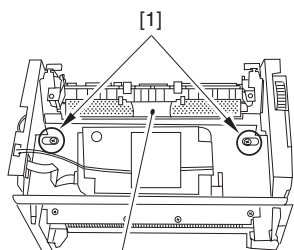

F-3-288

- 3) Disengage the connector [1] of the power supply board.  
4) Remove the grounding springs and the pressure springs [2] on both sides.  
5) Remove the pressure plates [3] on both sides.

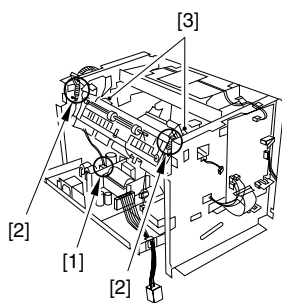

F-3-289

- 6) While holding the left and right frames [2] of the Fixing film unit [1], lift it up at an angle and remove it.

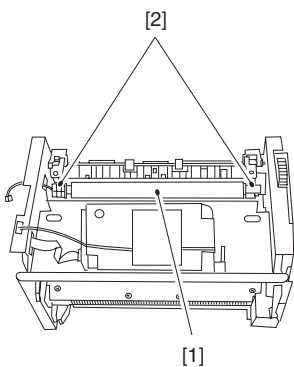

F-3-290

### 3.6.2.13 Removing the Fixing Pressure Roller

- 1) Remove the gear [1] by disengaging the claw.  
2) Take out the boss of the bushing [2], turn it, and remove the bushing.

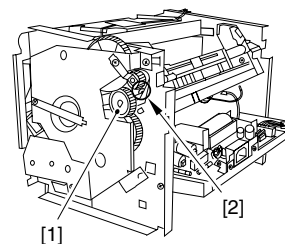

F-3-291

- 3) Hold the shorter shaft [2] of the Fixing pressure roller [1] and lift it up at an angle to remove it from the bushing. Remove the Fixing pressure roller by sliding it.

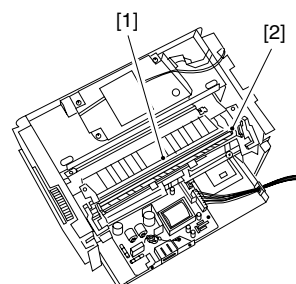

F-3-292



---

## Chapter 4 MAINTENANCE AND INSPECTION

---



---

---

# Contents

4.1 Periodically Replaced Parts .....	4-1
4.1.1 Periodic Replacement Parts .....	4-1
4.2 Periodical Service .....	4-1
4.2.1 Periodical Service .....	4-1
4.3 Cleaning .....	4-1
4.3.1 Items Requiring Cleaning .....	4-1
4.3.2 Cleaning Method (external covers).....	4-1
4.3.3 Cleaning Method (scanning unit).....	4-2
4.3.4 Cleaning Method (printer unit).....	4-2
4.4 Lubrications .....	4-3
4.4.1 Areas Requiring Application of Grease.....	4-3
4.4.2 Delivery Idler Gear .....	4-3
4.4.3 Wheel Shaft.....	4-4
4.4.4 Fixing Drive Transmission Gear.....	4-4
4.4.5 Large Gear .....	4-4
4.4.6 Feed Gear .....	4-5
4.4.7 Internal Gear .....	4-5
4.4.8 Large Gear Deceleration Gear/Plate R.....	4-5
4.4.9 Large Gear Bushing R .....	4-6
4.4.10 Main Motor .....	4-6
4.4.11 Drive Releasing Arm .....	4-7
4.4.12 FU Delivery Roller .....	4-7
4.4.13 Pickup Idler Gear .....	4-8
4.4.14 Feed Deceleration Gear.....	4-8
4.4.15 Fixing Deceleration Gear.....	4-8
4.4.16 FD Delivery Roller .....	4-9
4.4.17 Large Gear Bushing F .....	4-9
4.4.18 Pressure roller .....	4-9
4.4.19 Cassette Pickup Roller .....	4-10
4.4.20 CIS Shaft.....	4-10



---

## 4.1 Periodically Replaced Parts

---

### 4.1.1 Periodic Replacement Parts

No parts require periodic replacement in this printer.

## 4.2 Periodical Service

---

### 4.2.1 Periodical Service

The printer has no parts that require periodic servicing.

## 4.3 Cleaning

---

### 4.3.1 Items Requiring Cleaning

T-4-1

Work by	Item	Intervals
User	External covers	As needed (when soiled)
	Platen glass	When smears appear on image scanned from the platen glass
	Rear surface of the platen glass cover	When smears appear on image scanned from the platen glass
Service technician	Cassette pickup roller	When paper pickup performance has lowered
	Cassette separation pad	When paper separation performance has lowered
	Feed roller	When paper feed performance has lowered
	Transfer charging roller	When the back of paper tends to become soiled; or, when a white spot appears in the images at intervals of about 46 mm
	Static eliminator	When dots appear in images
	Paper feed guide	When the back of paper tends to become soiled
	Fixing entrance guide	When paper tends to become soiled; when a black line appears vertically at irregular intervals; when paper jams; when paper wrinkles
	Fixing film	When images tend to become soiled at intervals of about 57 mm
	Fixing pressure roller	When the back of paper shows traces at intervals of about 64 mm; when fixing faults occur; when paper jams; when paper wrinkles



Before starting cleaning work, be sure to turn off the power and disconnect the power plug to avoid fires and electric shocks.

---

### 4.3.2 Cleaning Method (external covers)

Moisten a soft cloth with water or solution of mild detergent, making sure it is well wrung; then, wipe the soiling. If you have used detergent, be sure to remove its residue using a soft, moist cloth. After removing all soiling, dry wipe the area with a soft, dry cloth.

4.3.3 Cleaning Method (scanning unit)

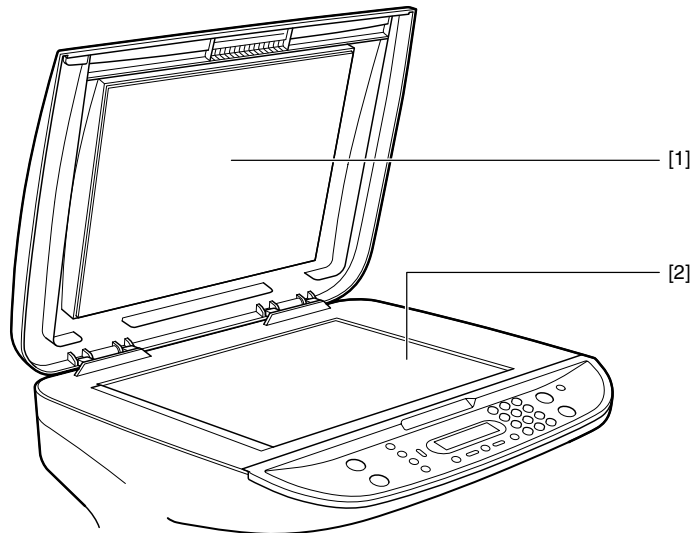

F-4-1

- [1] **Rear surface of the platen glass cover**  
Open the platen glass cover and wipe any dirt off with a soft, dry cloth.
- [2] **Platen glass**  
Open the platen glass cover and wipe any dirt off with a soft, dry cloth.

4.3.4 Cleaning Method (printer unit)

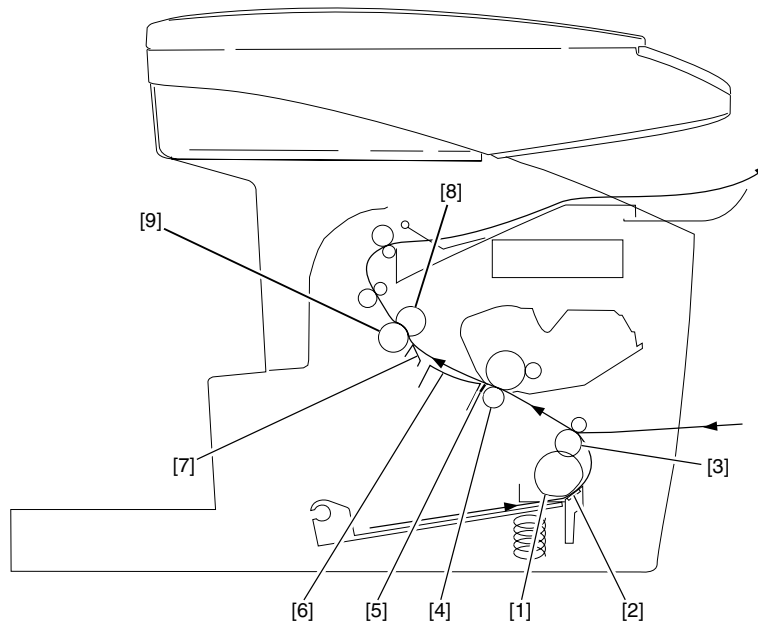

F-4-2

- [1] **Cassette Pickup Roller**  
Use lint-free paper to remove soiling.
- [2] **Cassette Separation Pad**  
Use lint-free paper to remove soiling.
- [3] **Feed Roller**  
Use lint-free paper to remove soiling.
- [4] **Transfer Charging Roller**  
Use lint-free paper to remove toner and paper lint.



- Do not touch the sponge area of the transfer charging roller to avoid soiling the back of paper or white spots in the images.
- Never use solvent.
- If the soiling cannot be removed using lint-free paper or the roller is deformed, replace the roller.

- [5] **Static Eliminator**  
Remove dust and paper lint using a brush.
- [6] **Paper Feed Guide**  
Use lint-free paper to remove soiling.
- [7] **Fixing Entrance Guide**  
Use lint-free paper moistened with isopropyl alcohol to remove the soiling.



**[8] Fixing Film**

Use lint-free paper to remove soiling.

**[9] Fixing Pressure Roller**

Use lint-free paper to remove soiling.

## 4.4 Lubrications

### 4.4.1 Areas Requiring Application of Grease

The machine has areas that require grease to permit smooth movement of parts or ensure good electrical conductivity. If you have replaced a part in these areas or if you have removed the grease, be sure to apply grease.

#### Printer unit

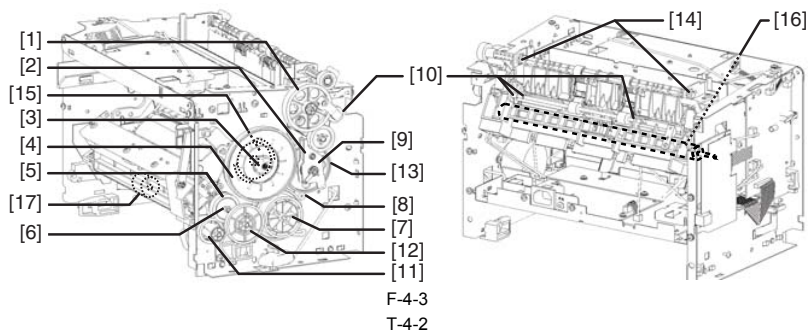

- |  |                               |
|--|-------------------------------|
| [1] Delivery idler gear                  | [10] FU delivery roller       |
| [2] Fixing drive transmission gear       | [11] Pickup idler gear        |
| [3] Large gear bushing R                 | [12] Feed deceleration gear   |
| [4] Large gear                           | [13] Fixing deceleration gear |
| [5] Feed gear                            | [14] FD delivery gear         |
| [6] Internal gear                        | [15] Large gear bushing F     |
| [7] Large gear deceleration gear/Plate R | [16] Pressure roller          |
| [8] Main motor                           | [17] Cassette pickup roller   |
| [9] Drive releasing arm                  |                               |

#### Scanner unit

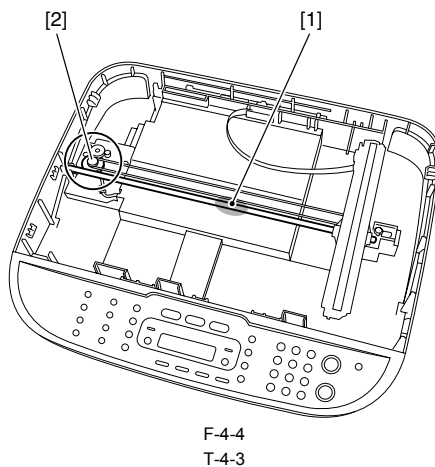

- |               |                 |
|---------------|-----------------|
| [1] CIS shaft | [2] Wheel shaft |
|---------------|-----------------|

### 4.4.2 Delivery Idler Gear

Area of application: [1]

Grease: MOLYKOTE EM-50L

Amount: 40 +/-10 mg

Location of application:

- 2 locations on gear support shaft in opposition

- spread in axial direction

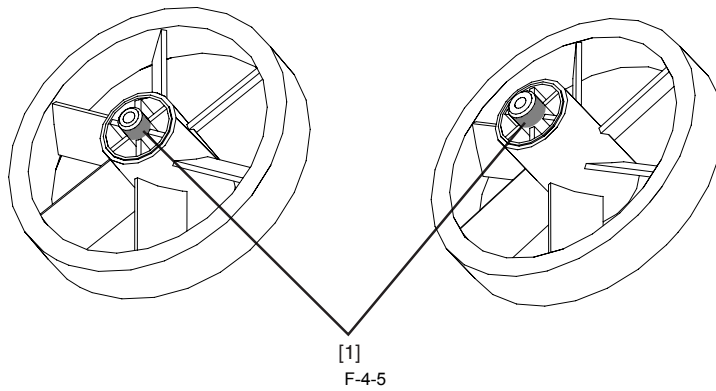

[1]  
F-4-5

#### 4.4.3 Wheel Shaft

Area of application: [1]  
Grease: MOLYKOTE EM-50L  
Amount: suitable amount  
Location of application:  
- part of wheel shaft where contacts the wheel unit

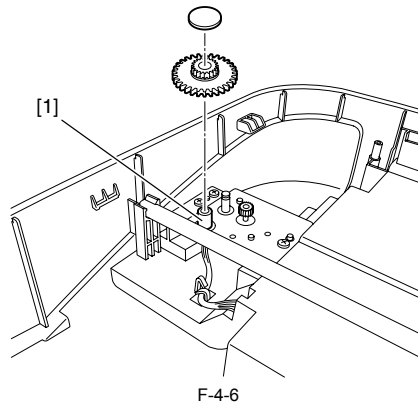

F-4-6

#### 4.4.4 Fixing Drive Transmission Gear

Area of application: [1]  
Grease: MOLYKOTE EM-50L  
Amount: 10 +/-5 mg  
Location of application:  
- 2 locations on gear butting ribs in opposition  
- spread in circumferential direction over a length of 1/4 or more

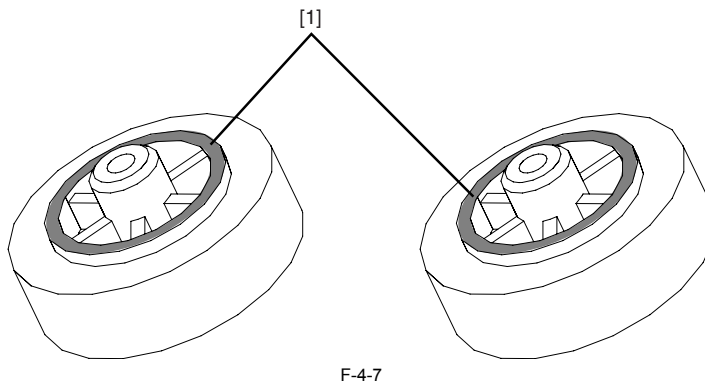

F-4-7

#### 4.4.5 Large Gear

Area of application: [1]  
Grease: MOLYKOTE EM-50L  
Amount: 20 +/-10 mg  
Location of application:  
- rib against which gear is butted  
- spread in circumferential direction over a length of 1/2 or more

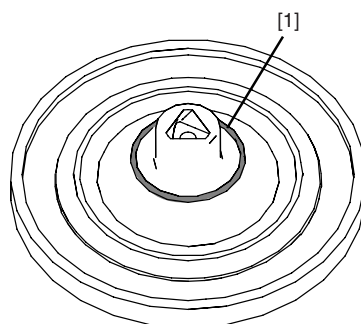

F-4-8

#### 4.4.6 Feed Gear

Area of application: [1]

Grease: MOLYKOTE EM-50L

Amount: 10 +/-5 mg

Location of application:

- 1 location on boss engaging with internal gear
- spread in axial direction

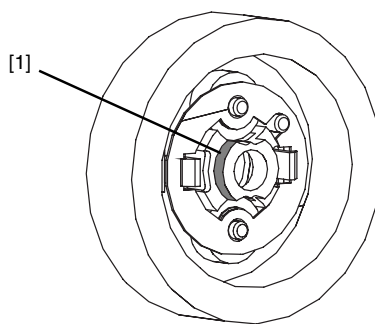

F-4-9

#### 4.4.7 Internal Gear

Area of application: [1]

Grease: MOLYKOTE EM-50L

Amount: 40 +/-10 mg

Location of application:

- 5 teeth or more of internal gear in opposition
- 2 locations in circumferential direction

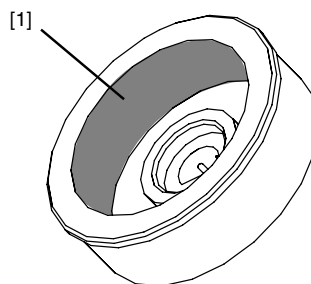

F-4-10

#### 4.4.8 Large Gear Deceleration Gear/Plate R

Area of application: [1]

Grease: MOLYKOTE EM-50L

Amount: 40 +/-10 mg

Location of application:

- 5 teeth or more (covering entire small-dia tooth area)

Area of application: [2]

Grease: MOLYKOTE EM-50L

Amount: 10 +/-5 mg

Location of application:

- support shaft of plate R (sliding surface against large gear deceleration gear)
- spread in axial direction

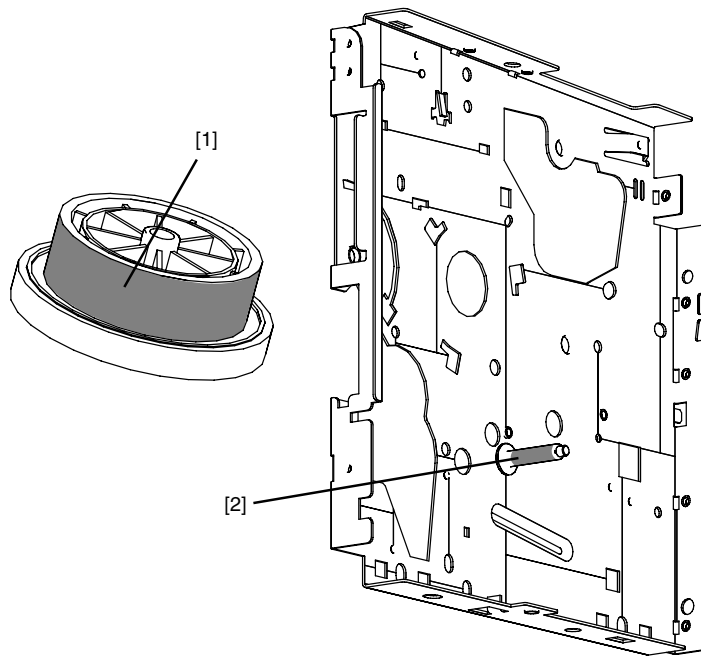

F-4-11

#### 4.4.9 Large Gear Bushing R

Area of application: [1]  
Grease: MOLYKOTÉ EM-50L  
Amount: 10 +/-5 mg  
location of application:  
- wall surface on inner circumferential side of bushing  
- spread in circumferential direction over a length of 1/2 or more

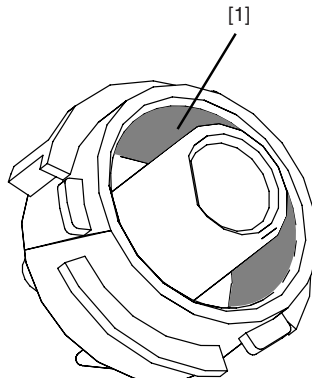

F-4-12

#### 4.4.10 Main Motor

Area of application: [1]  
Grease: MOLYKOTÉ EM-50L  
Amount: 40 +/-10 mg  
Location of application:  
- 5 teeth or more (covering entire gear width)

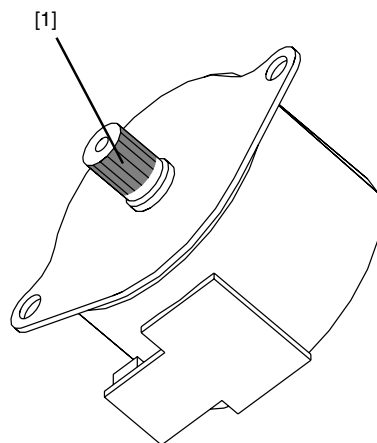

F-4-13

#### 4.4.11 Drive Releasing Arm

Area of application: [1]

Grease: MOLYKOTE EM-50L

Amount: 10 +/-5 mg

Location of application:

- 4 locations on sliding surface against gear support shaft of drive releasing arm

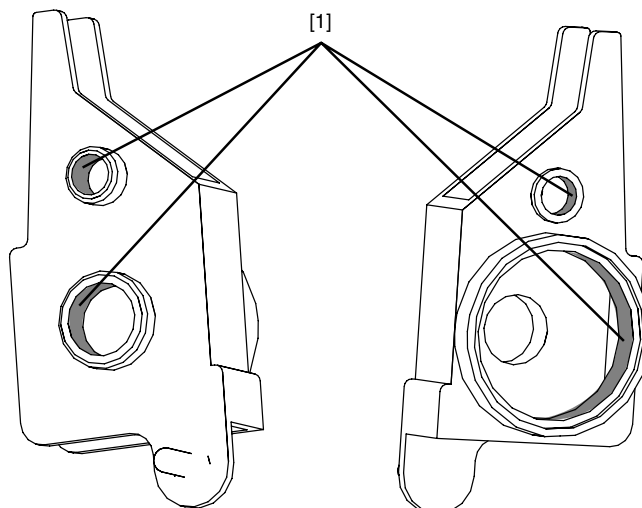

F-4-14

#### 4.4.12 FU Delivery Roller

Area of application: [1]

Grease: MOLYKOTE 41

Amount: 10 +/-5 mg

Location of application:

- edge of FU delivery roller shaft (sliding surface against FU grounding spring)

Area of application: [2]

Grease: MOLYKOTE EM-50L

Amount: 10 +/-5 mg

Location of application:

- sliding surface between FU delivery roller shaft and FU delivery roller bushing

Area of application: [3]

Grease: MOLYKOTE EM-50L

Amount: 10 +/-5 mg

Location of application:

- sliding surface between FU delivery roller shaft and delivery guide (FU delivery roller shaft stop rib)

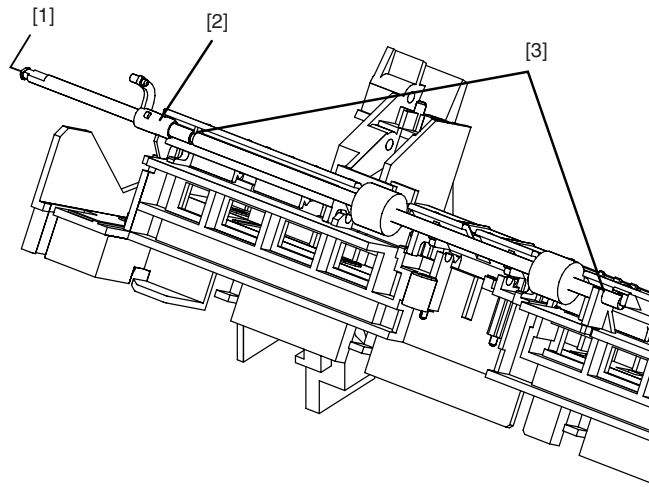

F-4-15

**4.4.13 Pickup Idler Gear**

- Area of application: [1]
- Grease: MOLYKOTE EM-50L
- Amount: 10 +/-5 mg
- Location of application:
  - 2 locations on pickup idler gear support shaft
  - 5 teeth or more (covering entire large-diameter tooth surface of pickup idler gear)

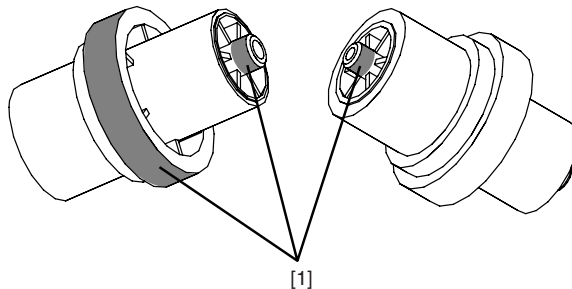

F-4-16

**4.4.14 Feed Deceleration Gear**

- Area of application: [1]
- Grease: MOLYKOTE EM-50L
- Amount: 10 +/-5 mg
- Location of application:
  - 2 locations on feed deceleration gear support shaft
  - spread in axial direction

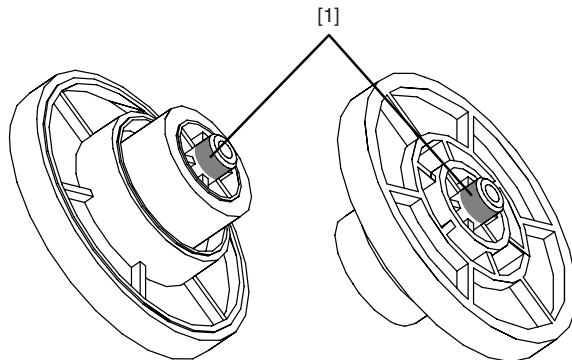

F-4-17

**4.4.15 Fixing Deceleration Gear**

- Area of application: [1]
- Grease: MOLYKOTE EM-50L
- Amount: 40 +/-10 mg
- Location of application:
  - 5 teeth or more (covering entire surface of fixing deceleration gear; small-diameter teeth)

- Area of application: [2]
- Grease: MOLYKOTE EM-50L

Amount: 10 +/-5 mg  
 Location application:  
 - tip of feed deceleration gear butting rib in circumferential direction over a length of 1/2 or more

Area of location: [3]  
 Grease: MOLYKOTE EM-50L  
 Amount: 10 +/-5 mg  
 Location of application:  
 - sliding surface against plate R of fixing deceleration gear in circumstantial direction over a length of 1/2 or more

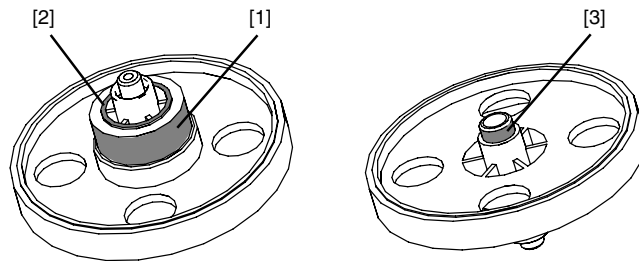

F-4-18

#### 4.4.16 FD Delivery Roller

Area of application: [1]  
 Grease: MOLYKOTE EM-50L  
 Amount: 30 +/-5 mg  
 Location of application:  
 - entire sliding surface against FD delivery bushing

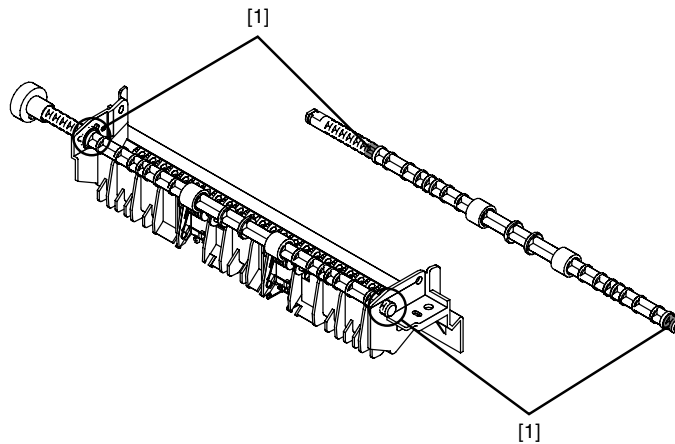

F-4-19

#### 4.4.17 Large Gear Bushing F

Area of application: [1]  
 Grease: MOLYKOTE EM-50L  
 Amount: 10 +/-5 mg  
 Location of application:  
 - entire sliding surface against large gear support shaft

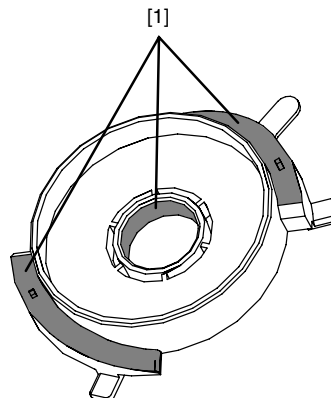

F-4-20

#### 4.4.18 Pressure roller

Area of application: [1]  
 Grease: MOLYKOTE 41

Amount: 10 +/-10 mg  
Location of application:  
- edge of pressure roller shaft (sliding surface against contact spring F)

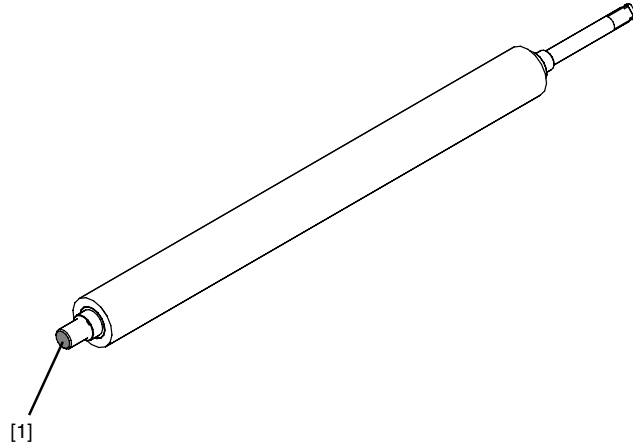

F-4-21

#### 4.4.19 Cassette Pickup Roller

Area of application: [1]  
Grease: MOLYKOTE EM-50L  
Amount: approx. 10 mg  
Location of application:  
- cassette pickup roller shaft, main unit frame (around the bushing), and the area where contacts the cassette pickup bushing

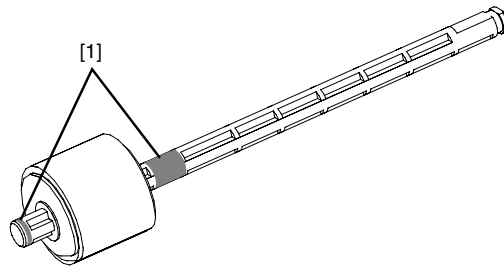

F-4-22

#### 4.4.20 CIS Shaft

Area of application: [1]  
Grease: MOLYKOTE EM-50L  
Amount: suitable amount  
Location of application:  
- part of CIS shaft where contacts the CIS unit (all the faces in the shaft direction)

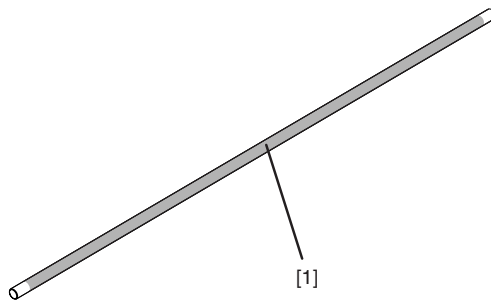

F-4-23



---

## Chapter 5 TROUBLESHOOTING

---

---

---

# Contents

5.1 Measurement and Adjustment .....	5-1
5.1.1 Basic Adjustments .....	5-1
5.1.1.1 Items of Adjustment .....	5-1
5.2 Service Tools.....	5-1
5.2.1 Special Tools.....	5-1
5.3 Error Code.....	5-1
5.3.1 Outline.....	5-1
5.3.1.1 Error Code Outline .....	5-1
5.3.1.2 Error Code .....	5-1
5.4 Service Mode .....	5-3
5.4.1 Outline.....	5-3
5.4.1.1 Service Data Setting .....	5-3
5.4.1.2 Service Data Entry Method.....	5-4
5.4.1.3 Service Data Flowchart.....	5-4
5.4.2 Service Soft Switch Settings (SSSW).....	5-4
5.4.2.1 Outline.....	5-4
5.4.2.1.1 Explanation of SOFT SWITCH .....	5-4
5.4.2.2 SSSW-SW02 .....	5-5
5.4.2.2.1 List of Functions .....	5-5
5.4.2.2.2 Details of Bit 2 and Bit 3.....	5-5
5.4.2.2.3 Details of Bit 5 .....	5-5
5.4.2.3 SSSW-SW10.....	5-5
5.4.2.3.1 List of Functions .....	5-5
5.4.2.3.2 Details of Bit 1 .....	5-5
5.4.2.3.3 Details of Bit 2 .....	5-5
5.4.2.4 SSSW-SW16.....	5-5
5.4.2.4.1 List of Functions .....	5-5
5.4.2.4.2 Details of Bit 3 .....	5-6
5.4.2.5 SSSW-SW30.....	5-6
5.4.2.5.1 List of Functions .....	5-6
5.4.2.5.2 Details of Bit 7 and Bit 8.....	5-6
5.4.2.6 SSSW-SW33 .....	5-6
5.4.2.6.1 List of Functions .....	5-6
5.4.2.6.2 Details of Bit 4 and Bit 5.....	5-6
5.4.2.7 SSSW-SW37.....	5-6
5.4.2.7.1 List of Functions .....	5-6
5.4.2.7.2 Details of Bit 1 through Bit 6.....	5-6
5.4.2.8 SSSW-SW51 .....	5-7
5.4.2.8.1 List of Functions .....	5-7
5.4.2.8.2 Details of Bit 3 and Bit 4.....	5-7
5.4.2.9 SSSW-SW54 .....	5-7
5.4.2.9.1 List of Functions .....	5-7
5.4.2.9.2 Details of Bit 6 and Bit 7.....	5-7
5.4.2.9.3 Details of Bit 8 .....	5-7
5.4.3 Report Output (REPORT).....	5-7
5.4.3.1 SERVICE DATA LIST.....	5-7
5.4.4 Test Mode (TEST) .....	5-7
5.4.4.1 Faculty Test.....	5-7
5.4.4.1.1 PRINT TEST PATTERN.....	5-7

## 5.1 Measurement and Adjustment

### 5.1.1 Basic Adjustments

#### 5.1.1.1 Items of Adjustment

The machine does not have items that are cited for adjustment.

Tool	Description	Parts No.
Grease (MOLYKOTE EM-50L)	Apply to specified areas.	HY9-0007
Grease (MOLYKOTE EMD-110)	Apply to specified areas.	HY9-0023
Grease (IF-20)	Apply to specified areas.	CK-8006
Grease (MOLYKOTE 41)	Apply to specified areas.	CK-8007

## 5.3 Error Code

### 5.3.1 Outline

#### 5.3.1.1 Error Code Outline

An error code is used to indicate a fault in a machine, and is indicated in the machine's LCD, showing the nature (symptoms) of the fault. Using the error code, the service man can readily find out how to correct the fault by simply

referring to the service manual.

An error code may be either of the following two types:

#### Service Error Codes

If a fault calls for a service man for correction, it is indicated as a service man error code in the form of "SYSTEM ERROR E+number."

#### 5.3.1.2 Error Code

##### System error code

T-5-2

Error code	Major cause/detection	Remedy
E198	Flash ROM write error.	- Turn the power OFF and then back ON.. - Replace the SCNT board.
E674	Modem error.	- Turn the power OFF and then back ON.. - Replace the SCNT board.

#### Scanner error code

T-5-3

Error code	Major cause/detection	Remedy
E225	CIS lamp has a fault.	- Turn the power OFF and then back ON.. - Replace the CIS unit.

#### Printer error code

T-5-4

Error code	Major cause/detection	Remedy
E000	The thermistor has an open circuit or a short circuit.	- Check the connector of the fixing film unit. - Replace the fixing film unit. - Replace the High-voltage power supply board. - Replace the DCNT board.
	The heater has an open circuit. The thermal fuse has blown.	
	The High-voltage power supply board has a fault.	
	The DCNT board has a fault.	
E100	The scanner assembly has a fault.	- Check the connector of the laser scanner assembly. - Replace the laser scanner assembly. - Replace the engine controller PCB.

#### Communication error code

T-5-5

Error Code	Description
0001	Nothing G3 signal received within 35 sec.
0003	Received DIS after sending DIS signal
0004	Received DCN after sending DTC signal
0009	Can't receive any signal within 35 sec. in manual polling mode.
0010	Received DCN signal after sending DTC signal in Polling Rx.
0011	Can't receive any correct response after sending DTC signal.
0012	Remote side Password not match in Polling Rx/our side no any file to be polling.
0013	Can't receive carrier within 6 sec. after sending CFR in date phase C.
0014	Can't receive T.30 signal after sending FTT signal.
0016	Receive DCN signal after sending PTT signal.
0017	Can't receive any response from remote side after sending DIS
0018	Can't detect energy within 6 sec after sending FTT command
0019	Received DCN signal sending CFR signal
001A	No energy on line over 6 sec. within phase C before any corrected ECM frame.
001D	Can't detect flag after sending CFR signal
001E	Timeout in V.17 ECM Rx phase C
0020	Can't correct frame within 6 sec at phase C.
0021	File full.
0022	Owing to noise interference on the line, receiving side can't receive correct data within specified time (no ECM)
0023	Can't receive correct signal after sending CFR signal

Error Code	Description
0030	Can't receive any signal within 6 sec. At phase D.
0031	Received incorrect signal at phase D (not EOP, MPS, EOM, DCN, PPS_Q, PPS_Q,etc)
0032	Can't receive carrier within 6 sec after sending MCF or RTP, RTN signal
0033	Received DCN signal at phase D within pages (not last page).
0039	In non_ECM mode, when machine already received the data doesn't receive 13.1 seconds
001F	Can't detect any G3 signal within 35 sec after sending DTC signal
003F	Remote side TSI not define in machine one touch or speed dial directory
0040	Can't receive carrier within 6 sec. after sending CTR.
0041	Can't receive carrier within 6 sec. after sending PPR.
0042	Can't receive correct signal after sending RNR signal
0043	Receive incorrect signal at phase D in ECM mode.
0044	Can't receive carrier/FSK signal within 6 sec. After sending MCF. In ECM mode.
0047	Can't receive correct signal or DCN received after sending ERR signal.
0048	Can't receive correct signal after receive PPS_PRI_Q
004B	Can't detect correct FSK signal even through detected FSK tone within 6 sec.
004C	Handshake fail during re-train or between page in V34 Rx.
004E	Receive DCN signal after sending DIS in V.34.
004F	Remote side disconnected after sending ANSam in V.8 phase.
0050	Can't receive any correct signal after detected CJ signal in V.8 phase.
0051	Can't receive phase 3 signal after phase 2 within 20 seconds in V.34.
0053	Modem disconnect after phase 4 in V.34.
0054	Remote side disconnect after phase 4 in V.8
0055	Receive incorrect signal after sending DIS signal in V.34
0056	Modem disconnect after sending CFR in V.34
0058	Can't detect image signal within 6 sec after modem enter to primary phase in V.34
005A	Modem cannot detect any correct ECM frame with 3 minutes in phase C.
005B	Modem can't detect control channel with 12 sec in phase C
005C	Detect busy tone within control channel after phase C.
005D	Modem can't detect any correct ECM frame with 12 sec in phase C.
005E	Can't detect control channel signal after received RCP frame within 6 sec
005F	Can't detect silence after sending JM signal for polling TX function.
0060	There are no any bulletin files to be polled in V.34.
0061	Machine cannot detect V.21 or V.8 signal with 35 sec.
0062	Modem disconnect in phase D after our side sending out flags sequence in control channel.
0063	Can't receive any flag sequence in control channel within 25 sec in phase D.
0064	Can't detect any control channel signal in phase D within 60 sec even through energy still on the line.
0065	Can't detect any control channel signal within 60 sec after detect silence in phase D.
0066	Can't receive T.30 signal or carrier after sending CFR in V.34.
0069	Capability no match paper size after received is DCS signal.
0070	User press stop key within receiving.
0071	Memory full within receiving.
0080	Can't detect any G3 signal within 35 sec. specified by ITU-T in phase B.
0081	Received DTC signal in transmission phase.
0082	Transmitting unit receives a signal other than DIS or DTC. And DCN in phase B.
0083	Detected FSK signal, but Can't receive any signal within 35 sec.
0084	Detect DCN signal in phase B.
0085	Transmitting unit sending DCS 3 times consecutively, but each time responds with DIS/DTC
0086	Detected responds signal other than DTC,DIS,FTT,DCN or CFR after sending DCS.
0087	Training attempt has failed because speed unit can't adjust to low lower speed.
0088	Received DCN signal after sending out DCS signal
008B	Receivers protocol of DIS is received, but it is not compatible with our machine.
008C	Remote side or our side not support capability.
008D	Receivers protocol of DIS is received, but remote side can't receive document temporary, may because by run out of paper or other reason.
008F	Modem not ready to received V.34 data within 6 sec after received CFR signal.
0090	Called side document not ready for our polling.
0091	Can't receive any commabd after send DCN signal 3 times consecutively
0093	Received DCN signal after sending out DCN signal
0094	Time out during transmit ECM frame or RCP command.
0095	Wrong ID number
0096	SUBADDRESS/PASSWORD capability not match in polling Rx mode.
009A	Can't detect any signal after sending CI signal.
009D	Remote side hang up before V.34 modem enter phase 2 state in V.34 polling Rx.
009E	Manual Tx over 15 minutes whin in phase C by non-ECM mode.
00A0	User stop or cancel transmission job.
00A1	Document JAM within transmission

Error Code	Description
00AE	Can't finished V.8 procedure or detect V.21 signal after CM signal
00AF	Modem can't enter into control channel after TX side sending out RCP signal for V34
00B1	Can't finish V.8 procedure or detect V.21 signal after ANSam signal within 35 sec.
00B2	Can't detect phase 2 signal after our side sending CJ signal within 30 sec
00B3	Can't detect correct V.21 or JM signal after sending CM or CJ signal.
00B4	Can't detect correct phase 2 signal within 25 second after CM/JM signal exchange.
00B5	Can't detect phase 3 signal after Phase 2
00B6	Can't detect phase 4 signal within 25 sec after CM/JM exchange.
00B8	Remote side disconnect after our side sending DCS signal in V.34.
00BA	Cannot received correct signal after our side sending DTC signal in V.34.
00BB	Every time our side received DIS signal after sending DTC in V.34.
00BC	Modem can't ready within 10 second after entering primary channel in V.34.
00BD	Can't detect correct V.21 or JM signal after detected FSK frequency.
00BE	Remote side no document to be polled after V.8 handshaking.
00BF	Capability no match after V.8 handshaking
00C1	At phase-D, transmitting units out EOP 3 times consecutively, but receive no answer from receiving unit.
00C2	Remote side disconnect after sending out V.8 CM signal.
00C4	After sending MPS signal, the received is not one of MCF, RTN, PIP, PIN, RTP, DCN.
00C5	Received DCN signal after sending MPS signal.
00C9	At phase D, sending MPS 3 times consecutively, but no answer from receiveing unit.
00CA	After sending EOP signal, the received is not one of MCF, RTN, PIP, PIN, PRI-EOP, DCN, RTP.
00CB	After sending EOP signal, the received is DCN signal.
00CF	Received incorrect signal after sending DTC signal for V.34 polling.
00D0	Received ERR signal after sending EOR_NULL.
00D1	Received incorrect response after sending PPS_EOP signal
00D2	Received DCN after sending PPS_EOP signal
00D3	Received DCN after sending PPS_NULL signal
00D8	Can't detect correct phase 3 signal for poling.
00D9	Can't detect correct phase 3 signal after detect silence after phase 2.
00DA	Can't detect phase 4 signal within 30 sec.
00DB	Can't received any T.30 signal within 30 sec within phase 4.
00DC	Received T.30 signal in phase 4 other than DCS, DIS or DTC
00DE	Remote side no SUB capability.
00E0	At phase-D, transmitting units out PPS_NULL 3 times consecutively but receive not answer.
00E1	Received incorrect response after sending PPS_NULL.
00E2	Can't receive any response in RR response procedure after sending PPS_NULL.
00E4	At phase D, transmitting units out PPS_MPS 3 times consecutively but receive no answer.
00E5	Received incorrect response after sending PPS_MPS signal
00E6	Can't receive any response in RR response procedure after sending PPS_MPS.
00E7	Reseived DCN after sending PPS_MPS.
00E8	At phase-D, transmitting units out PPS_EOP 3 times consecutively but receive no answer.
00E9	Receive PIN signal after sent last page data.
00EA	Can't receive any response in RR response procedure after sending PPS_EOP.
00EE	At phase-D, transmitting units out EOR_NULL 3 times consecutively but receive no answer.
00EF	Received incorrect response after sending EOR_NULL.
00F0	Can't receive any response in RR response procedure after sending EOR_NULL.
00F1	At phasa-D, transmitting units out EOR_MPS 3 times consecutively but receive no answer.
00F2	Received incorrect response after sending EOR_MPS.
00F3	Received ERR signal after sending EOR_MPS.
00F4	Can't receive any response in RR response procedure after sending EOR_MPS.
00F5	At phasa-D, transmitting units out EOR_EOP 3 times consecutively but receive no answer.
00F6	Received incorrect response after sending EOR_EOP
00F7	After Received ERR, our side can't received response after sending EOR_EOP command.
00FC	Can't receive any response after sending CTC.
00FD	Can't speed down to lower speed.
00FE	Memory full for transmission
00FF	REDAIL ALL FAIL

## 5.4 Service Mode

### 5.4.1 Outline

#### 5.4.1.1 Service Data Setting

Service mode has the following service data items. These items can be checked/changed according to the menu on the display.

#### SERVICE'S CHOICE

Use it to select service data to suit the country/region of installation, to reset the user data, or to set the transmission/reception speed.

#### ADJUST

Use it to execute margin adjustment for printing or reading.

#### VERSION DISPLAY

Use it to indicate version information on the display.

#### SOFT SWITCH

Use it to make settings that relate to basic fax service functions, as for correcting communication problems.

**REPORT**

Use it to output reports on various service data.

**CLEAR DATA**

Various data are initialized by selecting one of these setting items.

**FUNCTION**

Use it to print out a print pattern or to test the ADF for paper transport.

**H/W TEST**

Use it to execute sensor testing or key testing.

**5.4.1.2 Service Data Entry Method**

You can enter the Service Mode with the following operation.

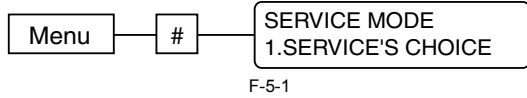

F-5-1

**5.4.1.3 Service Data Flowchart**

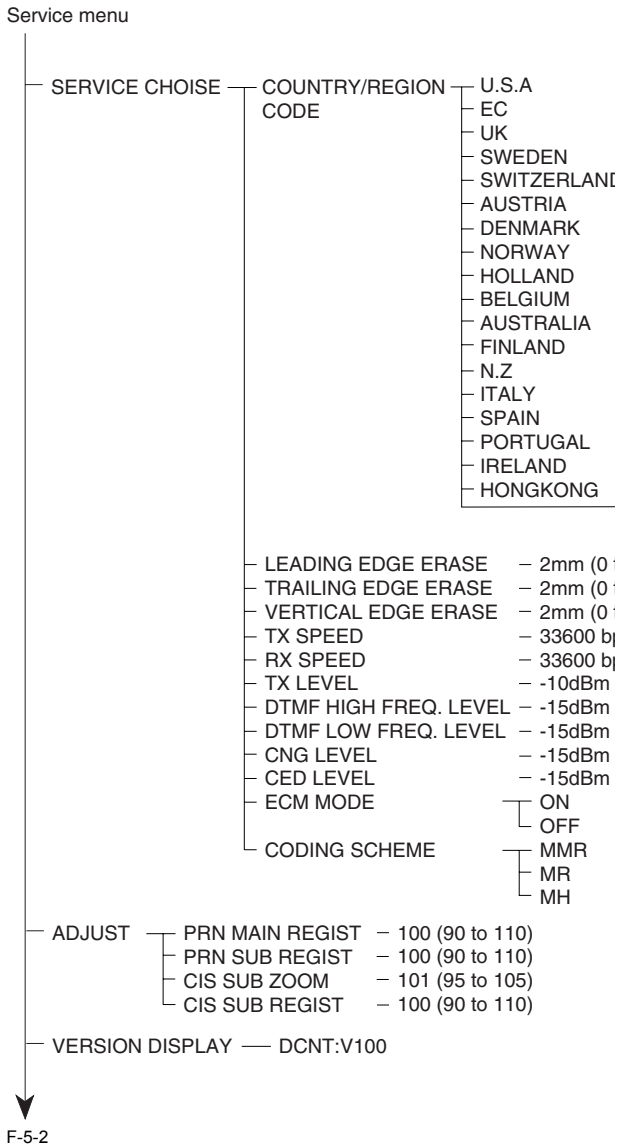

F-5-2

SOFT SWITCH	Bit	1	2	3	4	5	6	7	8	
SW01	-----									Not used
SW02	-00----									Not used
SW03~SW06:										
SW07	-----0									Not used
SW08	-----									Not used
SW09	-----									Not used
SW10	10-----									Not used
SW11~SW15:										
SW16	--0----									Not used
SW17	-----									Not used
SW18	0100----									Not used
SW19	-----									Not used
SW20	-----									Not used
SW21	-----									Not used
SW22	-----									Not used
SW23	-----									Not used
SW24	0100000-									Not used
SW25~SW29:										
SW30	-----10									Not used
SW31~SW36:										
SW37	---000--									Not used
SW38~SW45:										
SW46	---1----									Not used
SW47~SW50:										
SW51	--00----									Not used
SW52	-----									Not used
SW53	-----									Not used
SW54	-----011									Not used
SW55~SW64:										

F-5-3

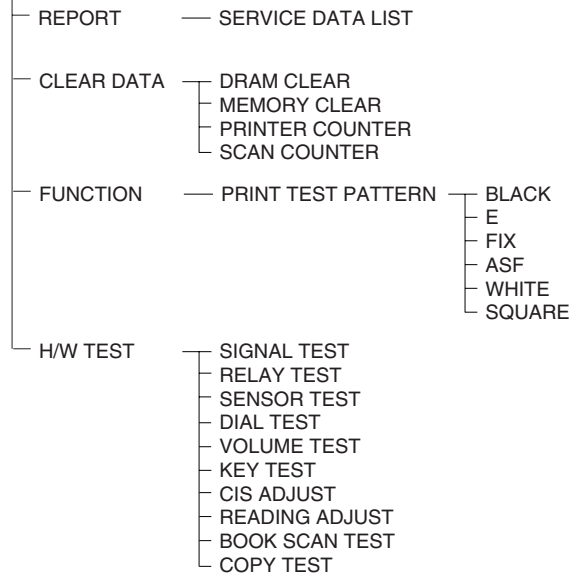

F-5-4

**5.4.2 Service Soft Switch Settings (SSSW)**

**5.4.2.1 Outline**

**5.4.2.1.1 Explanation of SOFT SWITCH**

The items registered and set by each of these switches comprise 8-bit switches. The figure below shows which numbers are assigned to which bits. Each bit has a value of either 0 or 1.

0012-6716

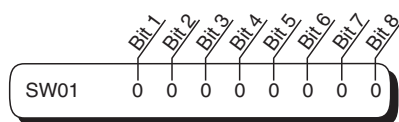

F-5-5

Below are examples showing how to read bit switch tables.

Function	1	0
Not used	-	-
Not used	-	-
Not used	-	-
Document scan width	LETTER	A4*
Not used	-	-
Not used	-	-
Not used	-	-
Not used	-	-

F-5-6

Indicates that the setting is "1".

Indicates that the setting is "0".

Indicates the default setting.

### 5.4.2.2 SSSW-SW02

#### 5.4.2.2.1 List of Functions

T-5-6

[0012-7129](#)

Bit	Function	1	0
1	Not used	-	-
2	RTN signal transmission condition	1	0*
3	RTN signal transmission condition	1	0*
4	Not used	-	-
5	Menu display of message language Display	Display	Do not display
6	Not used	-	-
7	Not used	-	-
8	Not used	-	-

#### 5.4.2.2.2 Details of Bit 2 and Bit 3

[0012-7130](#)

During reception if frequent errors occur because of RTN signal transmission, raise these parameters to loosen the RTN signal transmission conditions.

RTN signal transmission condition is the ratio of the number of error lines to the total number of lines per page of the received image.

The combination of bit 2 and bit 3 will bring about the following:

T-5-7

(Bit2, Bit3)= (0, 0) 10%  
 (1, 0) 15%  
 (0, 1) 20%

(1, 1) 25%

#### 5.4.2.2.3 Details of Bit 5

[0012-7196](#)

When Display is selected, add a Message Language menu to the user data System Setting. This allows selecting different languages which to show display and reports.

### 5.4.2.3 SSSW-SW10

#### 5.4.2.3.1 List of Functions

T-5-8

[0012-7131](#)

Bit	Function	1	0
1	Sound alarm if ends in error	Sound*	Do not sound
2	Page timer for manual transmission	15 min	impose no limit*
3	Not used	-	-
4	Not used	-	-
5	Not used	-	-
6	Not used	-	-
7	Not used	-	-
8	Not used	-	-

#### 5.4.2.3.2 Details of Bit 1

[0012-7132](#)

If a transmission ends in error, sound the alarm for 3 sec. If not desired, change it to "Do not sound".

#### 5.4.2.3.3 Details of Bit 2

T-5-9

[0012-7148](#)

Use it to select a page timer setting for manual transmission.

[0012-7133](#)

Bit	Function	1	0
1	Not used	-	-
2	Not used	-	-
3	Document scan width	LETTER	A4*
4	Not used	-	-

### 5.4.2.4 SSSW-SW16

#### 5.4.2.4.1 List of Functions

[0012-7148](#)

Bit	Function	1	0
5	Not used	-	-
6	Not used	-	-
7	Not used	-	-
8	Not used	-	-

**5.4.2.4.2 Details of Bit 3**

The document reading width can be selected.  
When selecting the "LTR" size, a "LTR" size document can be read in the "LTR" width (214 mm).

0012-7150

T-5-10

**5.4.2.5 SSSW-SW30**

**5.4.2.5.1 List of Functions**

0012-7135

Bit	Function	1	0
1	Not used	-	-
2	Not used	-	-
3	Not used	-	-
4	Not used	-	-
5	Not used	-	-
6	Not used	-	-
7	Pause time	1*	0
8	Pause time	1	0*

**5.4.2.5.2 Details of Bit 7 and Bit 8**

Use it to set the length of a pause; the following will be ture depending on the combination of bit 7 and bit 8:

0012-7136

T-5-11

(Bit7, Bit8)= (0, 0) 2.0 sec.  
(1, 0) 2.5 sec.

(0, 1) 3.0 sec.  
(1, 1) 3.5 sec.

**5.4.2.6 SSSW-SW33**

**5.4.2.6.1 List of Functions**

0012-7201

T-5-12

Bit	Function	1	0
1	Not used	-	-
2	Not used	-	-
3	Not used	-	-
4	NL Equalize (Transmission)	ON	OFF
5	NL Equalize (Reception)	ON	OFF
6	Not used	-	-
7	Not used	-	-
8	Not used	-	-

**5.4.2.6.2 Details of Bit 4 and Bit 5**

Selects whether the NL equalizer Transmission and reception is on or off. If frequent errors occur during transmission and reception because of line conditions, select the NL equalizer ON.

0012-7202

T-5-13

**5.4.2.7 SSSW-SW37**

**5.4.2.7.1 List of Functions**

0012-7137

Bit	Function	1	0
1	V.34 Baud rate (TX)	1	0*
2	V.34 Baud rate (TX)	1	0*
3	V.34 Baud rate (TX)	1	0*
4	V.34 Baud rate (RX)	1	0*
5	V.34 Baud rate (RX)	1	0*
6	V.34 Baud rate (RX)	1	0*
7	Not used	-	-
8	Not used	-	-

**5.4.2.7.2 Details of Bit 1 through Bit 6**

Select the maximum baud rate for V.34 transmission: 3429, 3200, 3000, 2800, and 2400.  
The following will be ture depending on the combination of bit 1 through bit 6 at time of transmission

0012-7138

T-5-14

(Bit1, Bit2, Bit3)= (0, 0, 0) 3429  
(1, 0, 0) 3200  
(0, 1, 0) 3000  
(1, 1, 0) 2800  
(0, 0, 1) 2400

at time of reception

T-5-15

(Bit4, Bit5, Bit6)= (0, 0, 0) 3429  
(1, 0, 0) 3200  
(0, 1, 0) 3000  
(1, 1, 0) 2800  
(0, 0, 1) 2400



## 5.4.2.8 SSSW-SW51

### 5.4.2.8.1 List of Functions

0012-7139

T-5-16

Bit	Function	1	0
1	Not used	-	-
2	Not used	-	-
3	Protocol monitor report	1	0*
4	Protocol monitor report	1	0*
5	Not used	-	-
6	Not used	-	-
7	Not used	-	-
8	Not used	-	-

### 5.4.2.8.2 Details of Bit 3 and Bit 4

(0, 1) Print if error

(1, 1) Not used

0012-7140

Use it to select the mode of printing a protocol monitor report; the following will be true depending on the combination of bit 3 and bit 4:

T-5-17

(Bit3, Bit4)= (0, 0) Do not print

(1, 0) Print

## 5.4.2.9 SSSW-SW54

### 5.4.2.9.1 List of Functions

0012-7141

T-5-18

Bit	Function	1	0
1	Not used	-	-
2	Not used	-	-
3	Not used	-	-
4	Not used	-	-
5	Not used	-	-
6	Date/time notation for report	1	0*
7	Date/time notation for report	1*	0
8	Month notation for report	1*	0

### 5.4.2.9.2 Details of Bit 6 and Bit 7

0012-7142

Use it to select the date/time notation for reports; the following will be true depending on the combination of bit 6 and bit 7:

T-5-19

(Bit6, Bit7)= (0, 0) YYYY MM/DD

(1, 0) MM/DD YYYY

(0, 1) DD/MM YYYY

(1, 1) Not used

### 5.4.2.9.3 Details of Bit 8

0012-7143

Use it to select the month notation for reports:

If [1] is selected, the month will be expressed in alphabet characters (e.g., 25.MAR.2005)

If [0] is selected, year, month, and day will all be expressed in numerals (e.g., 25.03.2005)

## 5.4.3 Report Output (REPORT)

### 5.4.3.1 SERVICE DATA LIST

SERVICE DATA LIST

```

NAME : VEGA
TEL   : 1234567
DATE  : 04/05/2005 11:55
COUNTRY/REGION CODE=OTHERS
-- SOFT SWITCH --
SW01-SW16  00 20 80 00  00 05 20 00 21 00 8E 12 02 AD 00
SW17-SW32  00 82 5A 60 20 15 48 02 04 22 00 A7 0F 59 2A 00
SW33-SW48  00 00 AD 8A 00 01 01 00 00 01 95 95 00 CA 00 A4
SW49-SW64  11 00 00 C1 C1 C0 00 00 00 00 00 00 0F 00 00 00
-- ADJUST --
PRN MAIN REGIST : 100          PRN SUB REGIST : 101
-- ROM ID --
06/14/2005 FV025-B1

```

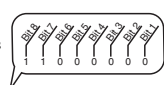

F-5-7

## 5.4.4 Test Mode (TEST)

### 5.4.4.1 Faculty Test

#### 5.4.4.1.1 PRINT TEST PATTERN

0012-6671

From the FUNCTION menu, select PRINT TEST PATTERN.

In this test, the printer unit will be used to print various patterns. For service

work, be sure to use the BLACK pattern and the SQUARE pattern. Use the BLACK print pattern to make sure that the printout is free of white lines and unevenness; on the other hand, use the SQUARE printout to make sure that the printout is free of image contraction, elongation, and soiling.

---

**MEMO**

After completion of the print test, if the printing was normal, copy a document. If there is any defect in the copied image, there is a defect in the scan section.

---

---

## Chapter 6 APPENDIX

---

# Contents

6.1 Outline of Electrical Components .....	6-1
6.1.1 Sensor .....	6-1
6.1.1.1 Arrangement of Sensors and Switches.....	6-1
6.1.2 PCBs .....	6-2
6.1.2.1 Arrangement of PCBs .....	6-2

---

## 6.1 Outline of Electrical Components

---

### 6.1.1 Sensor

#### 6.1.1.1 Arrangement of Sensors and Switches

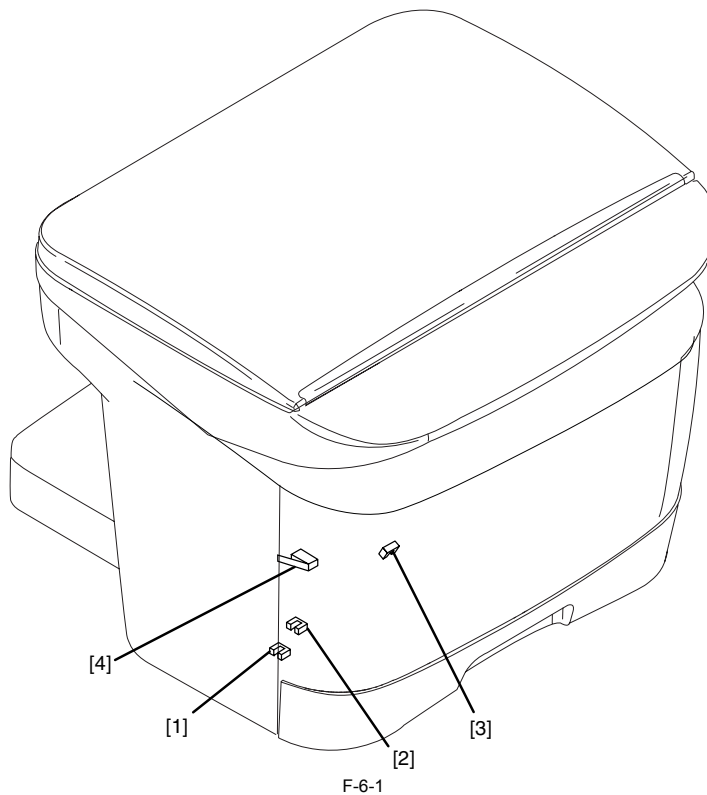

**[1] Cassette Paper Sensor**

Used to detect the presence/absence of paper in the cassette.

**[2] Manual Feed Paper Sensor**

Used to detect the presence/absence of paper in the manual feed section.

**[3] Paper Leading Edge Sensor (top sensor)**

Used to detect the leading/trailing edge of paper being moved.

**[5] Front Cover Switch**

Used to detect the state (open/closed) of the front cover.

6.1.2 PCBs

6.1.2.1 Arrangement of PCBs

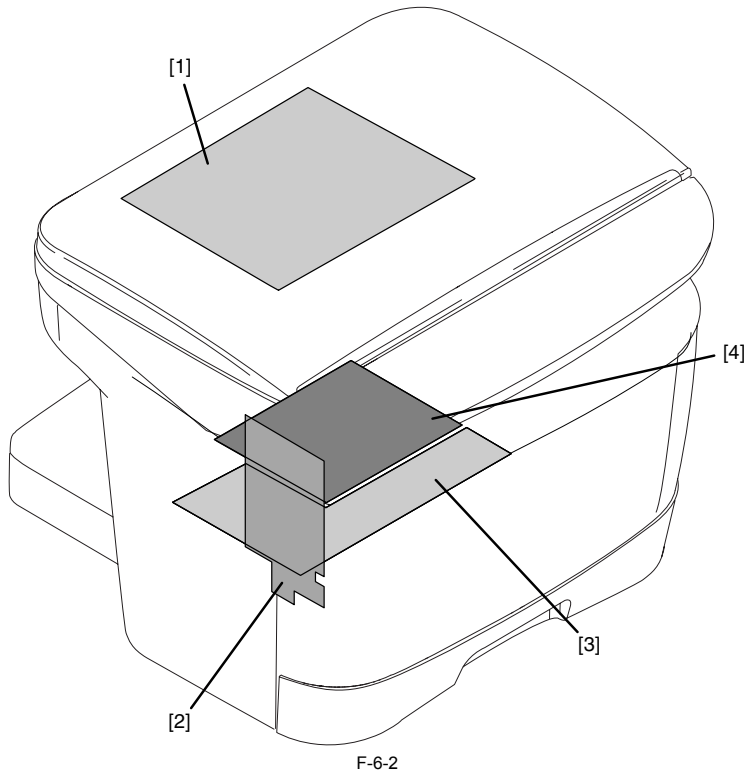

- [1] SCNT Board**  
Used to control the whole of the system.
- [2] ECNT Board**  
Used to control the operation of the printer unit.
- [3] High-Voltage Power Supply Board**  
Used to supply high-voltage power to the printer unit.
- [4] Power Supply Board**  
Used to control the supply of power to various components.